

IN5312a/IN5316HDa

User's Guide

Mode d'emploi

Benutzeranleitung

Manual de Uso

Guida all'uso

Gebruikershandleiding

Guia do Usuário

Användarhandbok

Руководство по пользователю

사용 설명서

用戶指南

Panduan Pengguna

Brugervejledning

Käyttöohje

Brukerhåndbok

Instrukcja obsługi

用戶手冊

Kullanım Kılavuzu



Regulatory Model: IN5312a/IN5316HDa

DISPERINDAG No. 0287/1.824.51/09.03

5012732800

InFocus

The New Way to Collaborate

Copyright

This publication, including all photographs, illustrations and software, is protected under international copyright laws, with all rights reserved. Neither this manual, nor any of the material contained herein, may be reproduced without written consent of the author.

© Copyright 2014

Disclaimer

The information in this document is subject to change without notice. The manufacturer makes no representations or warranties with respect to the contents hereof and specifically disclaims any implied warranties of merchantability or fitness for any particular purpose. The manufacturer reserves the right to revise this publication and to make changes from time to time in the content hereof without obligation of the manufacturer to notify any person of such revision or changes.

Trademark Recognition

Apple, Macintosh, and PowerBook are trademarks or registered trademarks of Apple Computer, Inc. IBM is a trademark or registered trademark of International Business Machines, Inc. Microsoft, PowerPoint, and Windows are trademarks or registered trademarks of Microsoft Corporation. Adobe and Acrobat are trademarks or registered trademarks of Adobe Systems Incorporated. DLP®, DLP Link and the DLP logo are registered trademarks of Texas Instruments and BrilliantColor™ is a trademark of Texas Instruments. InFocus, In Focus, and INFOCUS (stylized) are either registered trademarks or trademarks of InFocus Corporation in the United States and other countries.

DisplayPort is a registered trademark of the Video Electronics Standards Association, registered in the U.S. and the other countries.

All other product names used in this manual are the properties of their respective owners and are acknowledged.

Important Safety Information

**Important:**

It is strongly recommended that you read this section carefully before using the projector. These safety and usage instructions will ensure that you enjoy many years of safe use of the projector. Keep this manual for future reference.

Symbols Used

Warning symbols are used on the unit and in this manual to alert you of hazardous situations.

The following styles are used in this manual to alert you to important information.

Note:

Provides additional information on the topic at hand.

**Important:**

Provides additional information that should not be overlooked.

**Caution:**

Alerts you to situations that may damage the unit.

**Warning:**

Alerts you to situations that may damage the unit, create a hazardous environment, or cause personal injury.

Throughout this manual, component parts and items in the On-Screen Display (OSD) menus are denoted in bold font as in this example: “Push the **MENU** button on the remote control to open the **DISPLAY** menu.”

General Safety Information

- Do not open the unit case. Aside from the projection lamp, there are no user-serviceable parts in the unit. For servicing, contact InFocus at www.infocus.com/support
- Follow all warnings and cautions in this manual and on the unit case.
- The projection lamp is extremely bright by design. To avoid damage to eyes, do not look into the lens when the lamp is on.
- Do not place the unit on an unstable surface, cart, or stand.
- Avoid using the system near water, in direct sunlight, or near a heating device.
- Do not place heavy objects such as books or bags on the unit.

**Caution:**

Avoid using the projector in dusty environments.

**Important:**

Ventilation openings on the projector allow for good air circulation, which keeps the projector lamp cool. Do not obstruct any of the ventilation openings.

Projector Installation Notice

- Place the projector in a horizontal position
The tilt angle of the projector should not exceed 15 degrees. In addition, the projector should not be installed in any other way except desktop and ceiling mount positions. Otherwise lamp life could decrease dramatically, and may lead to other **unpredictable damage**.

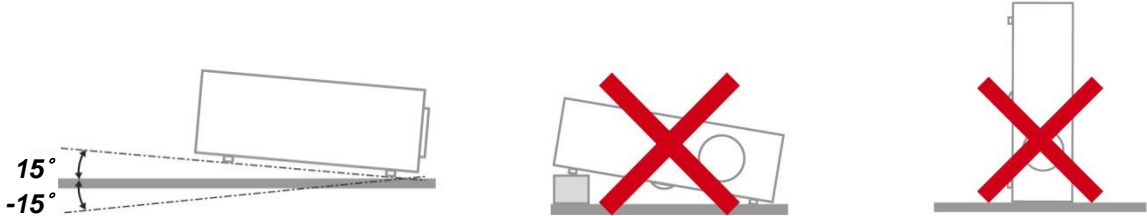

- Allow at least 50 cm (19.69 inch) clearance around the exhaust vent.

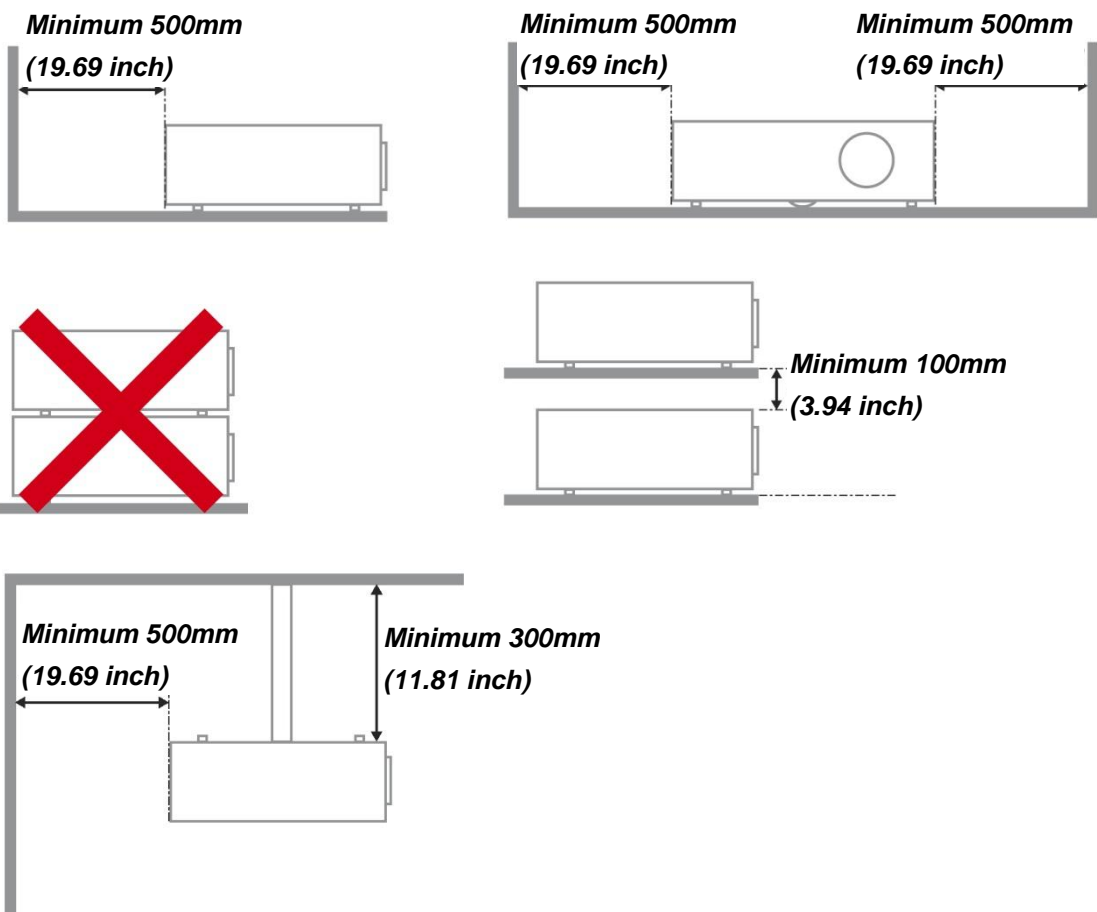

- Ensure that the intake vents do not recycle hot air from the exhaust vent.
- When operating the projector in an enclosed space, ensure that the surrounding air temperature within the enclosure does not exceed operation temperature while the projector is running, and the air intake and exhaust vents are unobstructed.
- All enclosures should pass a certified thermal evaluation to ensure that the projector does not recycle exhaust air, as this may cause the device to shutdown even if the enclosure temperature is within the acceptable operation temperature range.

Power Safety

- Only use the supplied power cord.
- Do not place anything on the power cord. Place the power cord where it will not be in the way of foot traffic.
- Remove the batteries from the remote control when storing or not in use for a prolonged period.

Replacing the Lamp

Replacing the lamp can be hazardous if done incorrectly. See [Replacing the Projection Lamp](#) on page 41 for clear and safe instructions for this procedure. Before replacing the lamp:

- Unplug the power cord.
- Allow the lamp to cool for about one hour.

Cleaning the Projector

- Unplug the power cord before cleaning. See [Cleaning the Projector](#) on page 45.
- Allow the lamp to cool for about one hour.

Regulatory Warnings

Before installing and using the projector, read the regulatory notices in the [Regulatory Compliance](#) section on page 57.

Important Recycle Instructions:



Lamp(s) inside this product contain mercury. This product may contain other electronic waste that can be hazardous if not disposed of properly. Recycle or dispose in accordance with local, state, or federal laws. For more information, contact the Electronic Industries Alliance at www.eiae.org. For lamp specific disposal information check www.lamprecycle.org.

Symbol Explanations



DISPOSAL: Do not use household or municipal waste collection services for disposal of electrical and electronic equipment. EU countries require the use of separate recycling collection services.

About this Manual

This manual is intended for end users and describes how to install and operate the DLP projector. Wherever possible, relevant information—such as an illustration and its description—has been kept on one page. This printer-friendly format is both for your convenience and to help save paper, thereby protecting the environment. It is suggested that you only print sections that are relevant to your needs.

Table of Contents

GETTING STARTED.....	1
PACKING CHECKLIST.....	1
VIEWS OF PROJECTOR PARTS.....	2
<i>Front-angled View</i>	2
<i>Top view—On-screen Display (OSD) buttons</i>	3
<i>Rear view</i>	4
<i>Bottom view</i>	6
REMOTE CONTROL PARTS.....	7
SETUP AND OPERATION.....	9
INSERTING THE REMOTE CONTROL BATTERIES.....	9
INSTALLING OR REMOVING THE OPTIONAL LENS.....	10
<i>Removing the Existing Lens From the Projector</i>	10
<i>Installing the New Lens</i>	11
STARTING AND SHUTTING DOWN THE PROJECTOR.....	12
ADJUSTING THE PROJECTOR LEVEL.....	14
ADJUSTING PROJECTED IMAGE POSITION USING SHIFT.....	15
<i>Adjusting the vertical image position</i>	15
<i>Adjusting the horizontal image position</i>	16
<i>Shift Range Diagram</i>	17
ADJUSTING ZOOM, FOCUS AND KEYSTONE.....	18
ADJUSTING THE VOLUME.....	19
ON-SCREEN DISPLAY (OSD) MENU SETTINGS.....	20
OSD MENU CONTROLS.....	20
<i>Navigating the OSD</i>	20
SETTING THE OSD LANGUAGE.....	21
OSD MENU OVERVIEW.....	22
IMAGE MENU.....	25
<i>Computer Menu</i>	26
<i>Advanced Feature</i>	27
<i>Color Manager</i>	28
SETTINGS 1 MENU.....	29
<i>Audio</i>	30
<i>Advanced 1 Feature</i>	31
<i>Advanced 2 Feature</i>	33
SETTINGS 2 MENU.....	34
<i>Status</i>	35
<i>Advanced 1 Feature</i>	36
<i>Advanced 2 Feature</i>	39
MAINTENANCE AND SECURITY.....	41
REPLACING THE PROJECTION LAMP.....	41
<i>Resetting the Lamp Timer</i>	44
CLEANING THE PROJECTOR.....	45
<i>Cleaning the Lens</i>	45
<i>Cleaning the Case</i>	45
TROUBLESHOOTING.....	46
COMMON PROBLEMS AND SOLUTIONS.....	46
TIPS FOR TROUBLESHOOTING.....	46
LED ERROR MESSAGES.....	47
IMAGE PROBLEMS.....	47
LAMP PROBLEMS.....	48
REMOTE CONTROL PROBLEMS.....	48
AUDIO PROBLEMS.....	49
HAVING THE PROJECTOR SERVICED.....	49
HDMI Q & A.....	50

SPECIFICATIONS 51

 SPECIFICATIONS 51

 PROJECTION DISTANCE VS. PROJECTION SIZE (1080P) 52

Projection Distance and Size Table 52

 PROJECTION DISTANCE VS. PROJECTION SIZE (XGA) 53

Projection Distance and Size Table 53

 TIMING MODE TABLE 54

 PROJECTOR DIMENSIONS 56

REGULATORY COMPLIANCE 57

 FCC WARNING 57

 CANADA 57

 WEEE 57

 SAFETY CERTIFICATIONS 57

APPENDIX I 58

 SERIAL COMMUNICATION 58

GETTING STARTED**Packing Checklist**

Carefully unpack the projector and check that the following items are included:

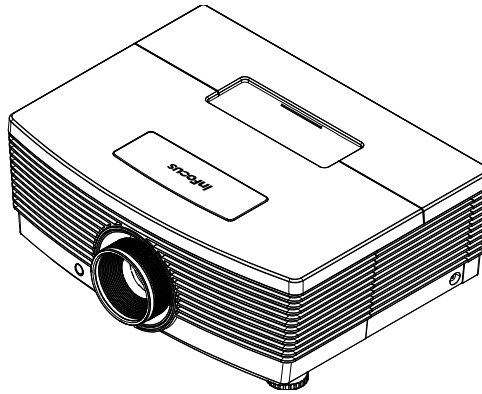

DLP PROJECTOR

REMOTE CONTROL
(BATTERIES NOT INCLUDED)CD-ROM
(THIS USER'S MANUAL)

QSC

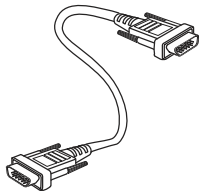

VGA CABLE

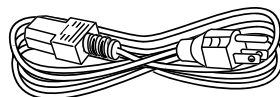
POWER CORD
(VARIES PER COUNTRY)SAFETY & WARRANTY
BOOKLET

Contact your dealer immediately if any items are missing, appear damaged, or if the unit does not work. It is recommended that you keep the original packing material should you ever need to return the equipment for warranty service.

**Caution:**

Do not place the project in direct sunlight, humid, greasy or dusty places or in places where the projector may come into contact with smoke or steam.

Views of Projector Parts

Front-angled View

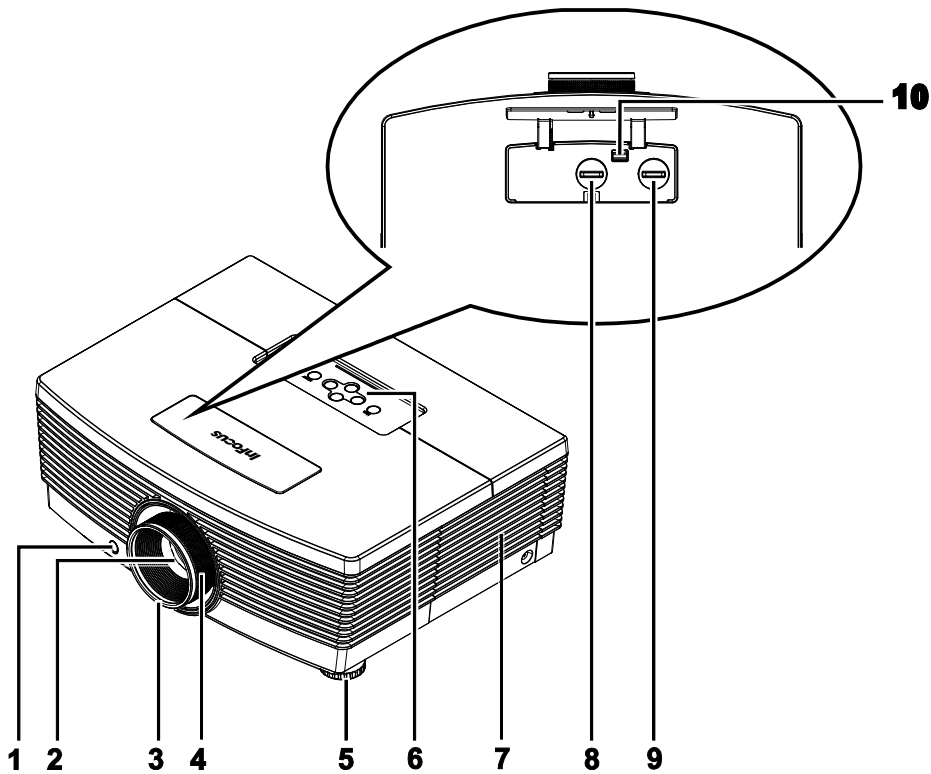

ITEM	LABEL	DESCRIPTION	SEE PAGE:
1.	IR receiver	Receives the IR signals from the remote control.	7
2.	Lens	Projection Lens.	
3.	Focus ring	Focuses the projected image.	17
4.	Zoom ring	Enlarges the projected image.	
5.	Elevator foot	Adjusts level of projector.	14
6.	Function keys	See Top view—On-screen Display (OSD) buttons.	3
7.	Lamp cover	Remove cover to replace lamp.	41
8.	Vertical lens shift	Adjusts the image position vertically.	15
9.	Horizontal lens shift	Adjusts the image position horizontally.	16
10.	Lens release button	Press the release button before attempting to replace the lens.	10

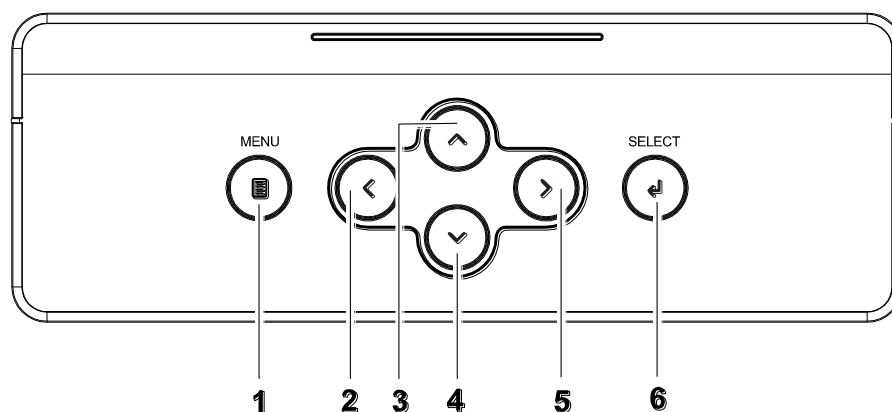
Top view—On-screen Display (OSD) buttons

ITEM	LABEL	DESCRIPTION	SEE PAGE:
1.	MENU	Open and exit OSD menus.	20
2.	◀ (Left cursor)	Navigate and change settings in the OSD. Quick Menu – For Volume	
3.	▲ (Up cursor)	Navigate the OSD. Quick Menu – For Keystone.	
4.	▼ (Down cursor)	Navigate the OSD. Quick Menu – For Keystone.	
5.	▶ (Right cursor)	Navigate and change settings in the OSD. Quick Menu – For Volume.	
6.	SELECT	Enter or confirm highlighted OSD menu item.	

Rear view

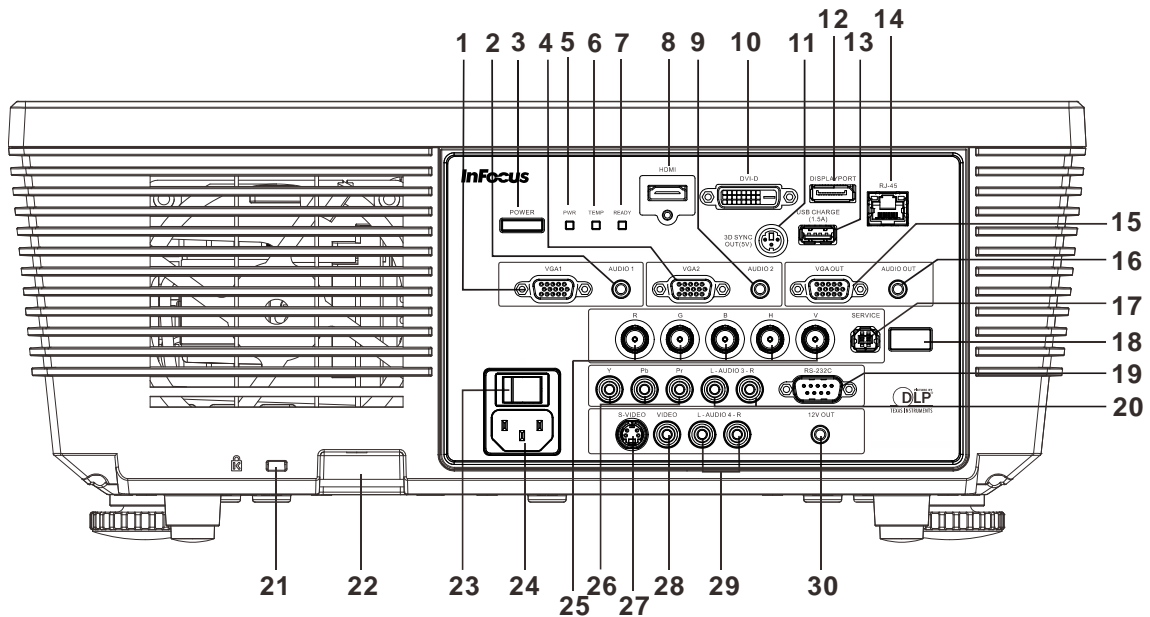

ITEM	LABEL	DESCRIPTION	SEE PAGE:	
1.	VGA1	Connect the RGB CABLE from a computer or a video enabled device.		
2.	AUDIO 1	Connect the AUDIO CABLE from an input device.		
3.	POWER button	Turns the projector on or off (main power switch must be turned on first).	12	
4.	VGA2	Connect the RGB CABLE from a computer or a video enabled device.		
5.	PWR LED	Solid Amber	Standby	47
		Solid Blue	Normal operation	
		Flashing Amber	Powering on or powering/cooling down.	
6.	TEMP LED	Solid Red	Overheating	
7.	READY LED	Solid Red	Normal operation	
		Flashing Red	Lamp is not ready	
8.	HDMI	Connect the HDMI CABLE from an HDMI device.		
9.	AUDIO 2	Connect the AUDIO CABLES from an input device.		
10.	DVI-D	Connect the DVI cable (not supplied) from a computer.		
11.	3D SYNC OUT (5V)	Connect 3D IR glasses receiver unit.		
12.	DISPLAYPORT	Connect a DISPLAYPORT CABLE to a DISPLAYPORT source.		
13.	USB CHARGE (1.5A)	For USB charge.		
14.	RJ45	Connect a LAN CABLE for networking purposes.		
15.	VGA OUT	Connect the RGB cable to a display (Pass through by VGA1 only).		
16.	AUDIO OUT	Connect an AUDIO CABLE to an external speaker system.		

17.	SERVICE	For service use.	
18.	IR receiver	Receives the remote control IR signal.	7
19.	RS-232	Connects RS-232 serial port cable for remote control.	
20.	AUDIO 3 (L and R)	Connect the AUDIO CABLE from an input device.	
21.	Security Lock	Connect a security lock system to the projector and attach to a permanent object.	
22.	Safety Cable Anchor	Secure a ceiling mount safety cable to this anchor.	
23.	Power Switch	Connects AC power to the projector.	12
24.	AC IN	Connect the POWER CABLE.	
25.	BNC	Connect the BNC CABLES from a computer or a video enabled device.	
26.	YPbPr	Connect the COMPONENT CABLE from a component video enabled device.	
27.	S-VIDEO	Connect the S-VIDEO CABLE from a video device.	
28.	VIDEO	Connect the COMPOSITE CABLE from a video device.	
29.	AUDIO 4 (L and R)	Connect the AUDIO CABLES from an input device.	
30.	12V OUT	When connected to the screen through a commercially available cable, the screen deploys automatically on start up of the projector. The screen retracts when the projector is powered off (see notes below).	

DC12V Trigger Note:

- To use this feature, you must plug in the connector before turn on/off the projector.
- Screen controllers are supplied and supported by screen manufacturers.
- Do not use this jack for anything other than intended use.

Connectivity Note:

If your video equipment has multiple connection options, please note that HDMI provides the highest quality image, followed by Component and then S-video. Composite provides the least quality image.



Warning:

As a safety precaution, disconnect all power to the projector and connecting devices before making connections.

Bottom view

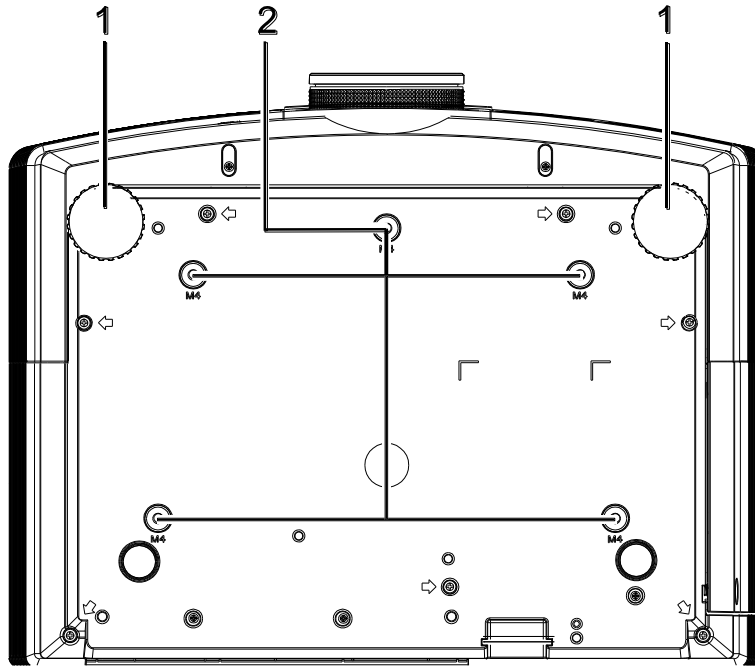

ITEM	LABEL	DESCRIPTION	SEE PAGE:
1.	Leveling/Elevator Feet	Raise and rotate the feet to change and fine tune the angle of the projector.	14
2.	Ceiling support holes	Only use with an InFocus ceiling mount system (p/n PRJ-MNT-UNIV). See your InFocus dealer or go to www.infocusstore.com .	

Note:

If you are installing the projector on the ceiling, we strongly recommend using InFocus approved ceiling mounts for proper fitting, ventilation and installation. Refer to the installation guide that comes with the InFocus Ceiling Mount kit for more information. The warranty does not cover any damage caused by use of non-approved ceiling mount kits or by installing in an improper location.

Remote Control Parts

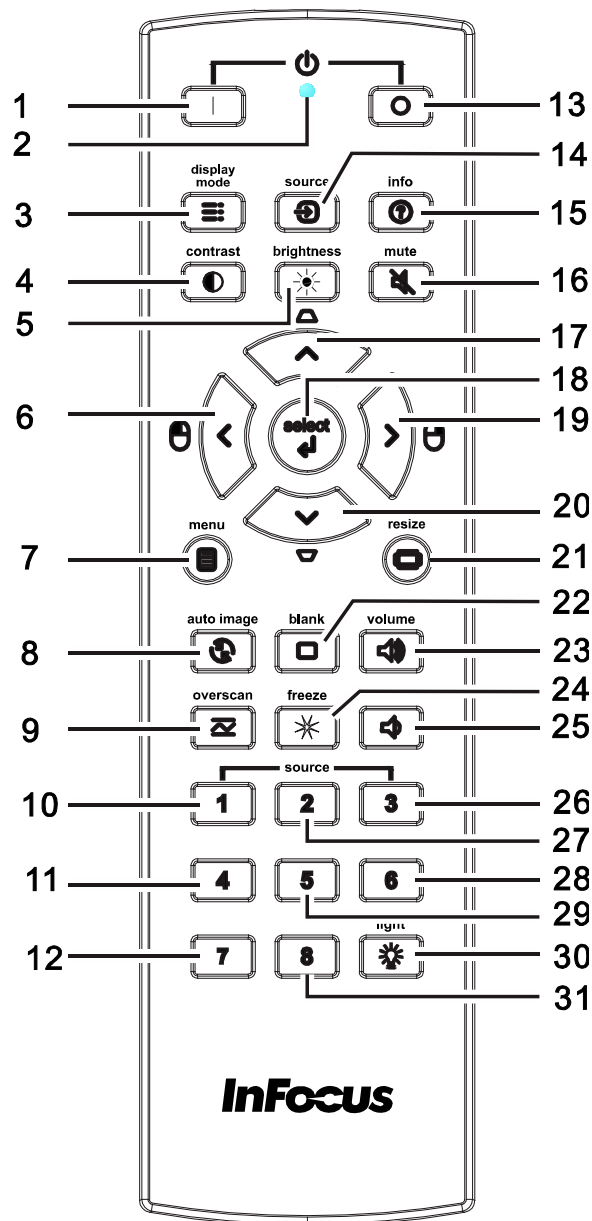

Important:

1. Avoid using the projector with bright fluorescent lighting turned on. Certain high-frequency fluorescent lights can disrupt remote control operation.

2. Be sure nothing obstructs the path between the remote control and the projector. If the path between the remote control and the projector is obstructed, you can bounce the signal off certain reflective surfaces such as projector screens.

3. The buttons and keys on the projector have the same functions as the corresponding buttons on the remote control. This user's manual describes the functions based on the remote control.

ITEM	LABEL	DESCRIPTION	SEE PAGE:
1.	Power ON	Turn the projector on.	12
2.	LED indicator	Only lights when the remote keys are pressed.	
3.	Display Mode	Choose a suitable preset mode for usage environment.	
4.	Contrast	Display the Contrast setting bar and use the right and left keys to adjust.	
5.	Brightness	Display the Brightness setting bar and use the right and left keys to adjust.	
6.	Left cursor	When the OSD is displayed, this button navigates to the left. When USB has been connected to the projector and PC, the previous presentation slide is displayed.	20
7.	Menu	Display the OSD menu.	
8.	Auto image	Re-synchronize the PC image.	
9.	Overscan	Adjust overscan.	
10.	Source-1	VGA 1 / 2	
11.	Source-4	DISPLAYPORT	
12.	Source-7	S-Video	
13.	Power OFF	Turn the projector off.	13
14.	Source	Display the source menu.	
15.	Info	Display projector information.	
16.	Mute	Mute the audio.	
17.	Up cursor / Keystone+	When the OSD is displayed, this button navigates up the menu. Otherwise it adjusts keystone.	20
18.	Select	Enter and confirm settings in the OSD.	
19.	Right cursor	When the OSD is displayed, this button navigates to the right. When USB has been connected to the projector and PC, the next presentation slide is displayed.	
20.	Down cursor / Keystone -	When the OSD is displayed, this button navigates down the menu. Otherwise it adjusts keystone.	
21.	Resize	Change the image aspect ratio.	
22.	Blank	Blank the screen.	
23.	Volume+	Increase the volume.	
24.	Freeze	Freeze video.	
25.	Volume-	Decrease the volume.	
26.	Source-3	DVI-D	
27.	Source-2	HDMI	
28.	Source-6	Component	
29.	Source-5	RGBHV	
30.	Light	Turn the remote control backlight on or off.	
31.	Source-8	Composite	

SETUP AND OPERATION**Inserting the Remote Control Batteries**

1. Remove the battery compartment cover by sliding the cover in the direction of the arrow.

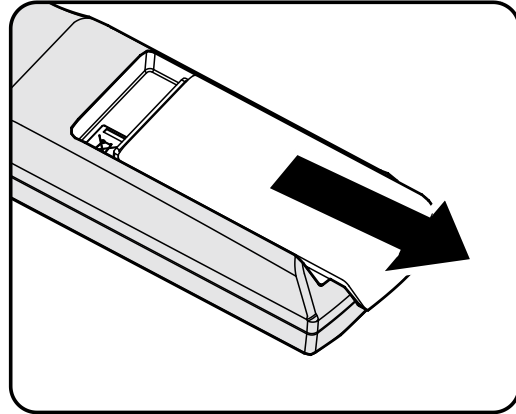

2. Insert batteries (not included) as shown in the illustration.

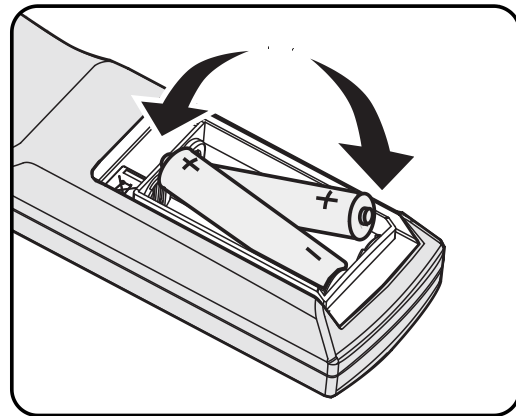

3. Replace the cover.

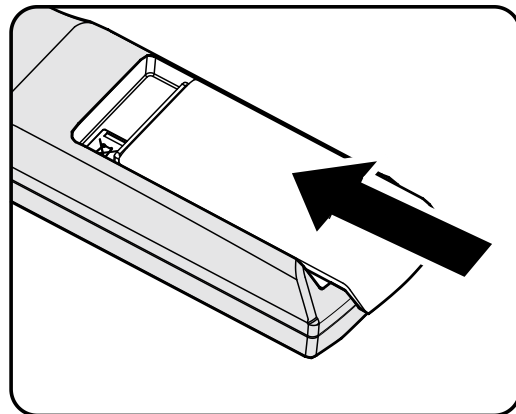
**Caution:**

1. Only use AA batteries (Alkaline batteries are recommended).
2. Dispose of used batteries according to local ordinance regulations.
3. Remove the batteries when not using the projector for prolonged periods.
4. Do not mix old and new batteries, or mix battery types.

Installing or Removing the Optional Lens



Caution:

- Do not shake or place excessive pressure on the projector or the lens components as the projector and lens components contain precision parts.
- Before removing or installing the lens, be sure to turn off the projector, wait until the cooling fans stop, and turn off the main power switch.
- Do not touch the lens surface when removing or installing the lens.
- Keep fingerprints, dust or oil off the lens surface.
- Do not scratch the lens surface.
- Work on a level surface with a soft cloth under it to avoid scratching.
- If you remove and store the lens, attach the lens cap to the projector to keep off dust and dirt.

Removing the Existing Lens From the Projector

- 1.** Push and release the top cover to open as shown.

- 2.** Push the LENS RELEASE button to the unlock position.

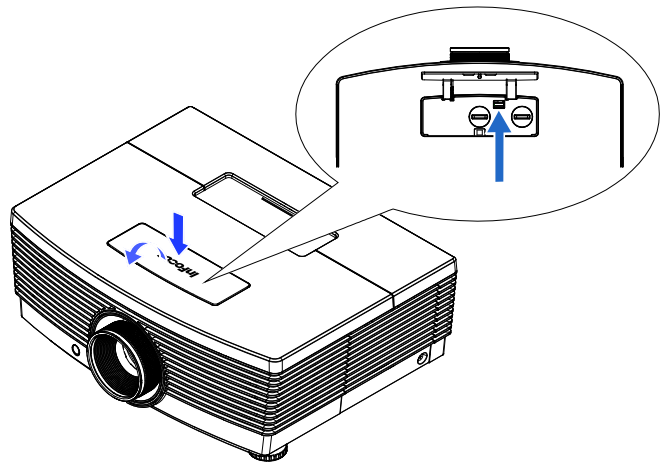

- 3.** Grasp the lens.

- 4.** Rotate the lens counterclockwise. The existing lens will be disengaged.

- 5.** Pull out the existing lens slowly.

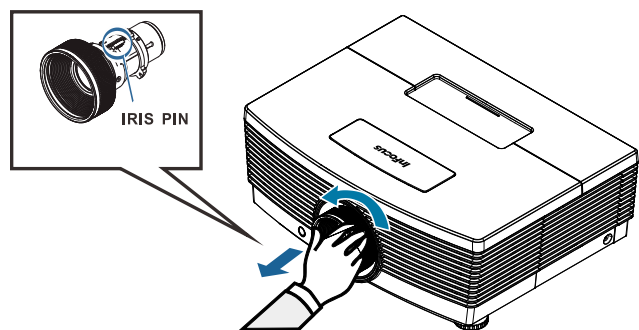

Installing the New Lens

1. Align the notches and correctly position the electrical contact pad as shown in the picture.

Note:
Pin of IRIS should be in the direction as shown in the picture.

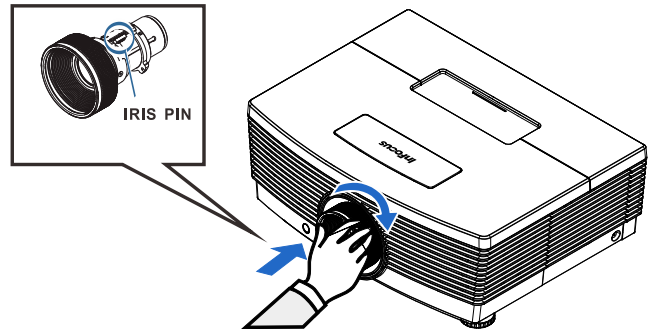

2. Rotate the lens clockwise until you feel it click into place.

Starting and Shutting down the Projector

1. Remove the lens cap.
2. Connect the power cord to the projector. Connect the other end to a wall outlet. Verify that the AC Power switch on the back of the unit is turned on. When connected, the PWR LED will turn solid Red.
3. Turn on the lamp by pressing the  button on the rear of the projector or the Power On button on the remote. The PWR LED will become solid Green. The startup screen will display in approximately 30 seconds.

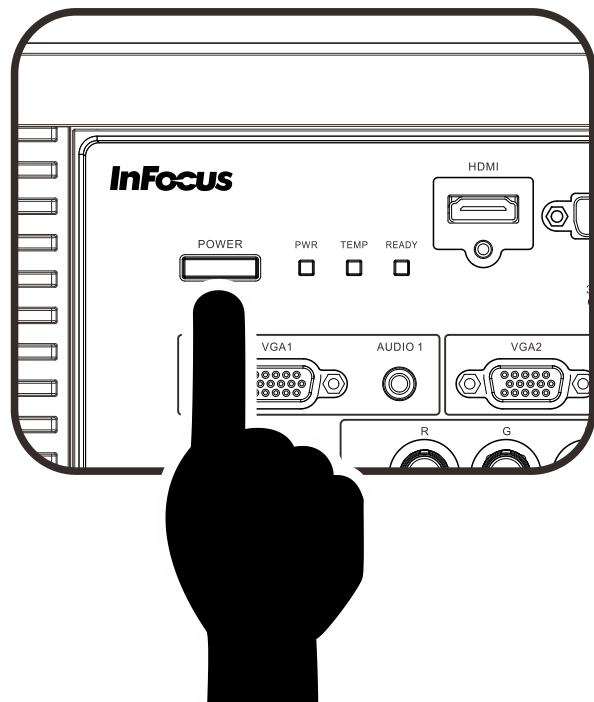
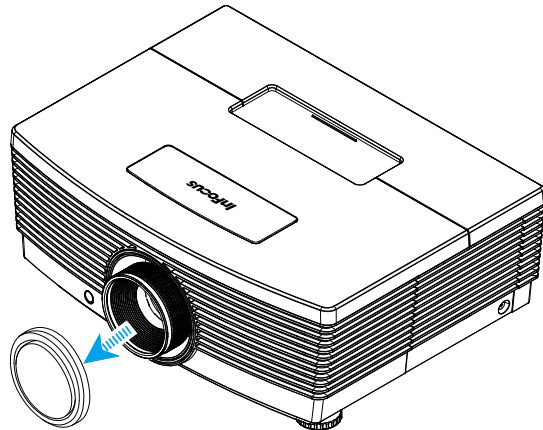

4. If more than one input device is connected, press the **SOURCE** button and use ▲▼ to scroll among devices.



- DVI : Digital Visual Interface
- HDMI : High Definition Multimedia Interface (HDMI)
- DisplayPort : DisplayPort input
- VGA 1 / 2 : Analog RGB1 / 2
- BNC : Analog / serial digital interface video inputs
- Component Video : DVD input YCbCr / YPbPr, or HDTV input
- S-Video : Super video (Y/C separated)
- Composite Video : Traditional composite video

5. To turn the projector off, press the Power OFF button (⏻), on the projector keypad or remote. When the POWER OFF window appears, press the Power OFF button (⏻) again.

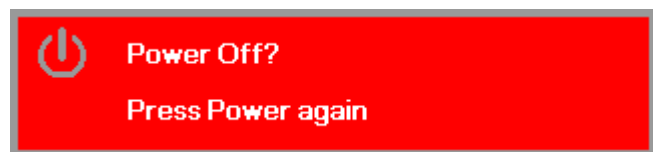

The projector turns off.



Caution:

1. Be sure to remove the lens cap before starting projector.
2. Do not unplug the power cord until the READY LED stops flashing—indicating the projector has cooled down.

Adjusting the Projector Level

Take note of the following when setting up the projector:

- *The projector table or stand should be level and sturdy.*
- *Position the projector so that it is perpendicular to the screen.*
- *Remove and discard the foam spacers on the rear leveling feet before adjusting the projection angle.*
- *Ensure the cables are in a safe location. You could trip over them.*

- 1.** To raise the level of the projector, twist the leveling feet clockwise.

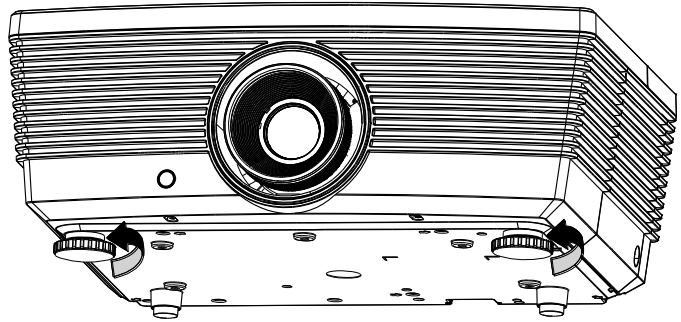

- 2.** To lower the level of the projector, lift the projector and twist the leveling feet counterclockwise.

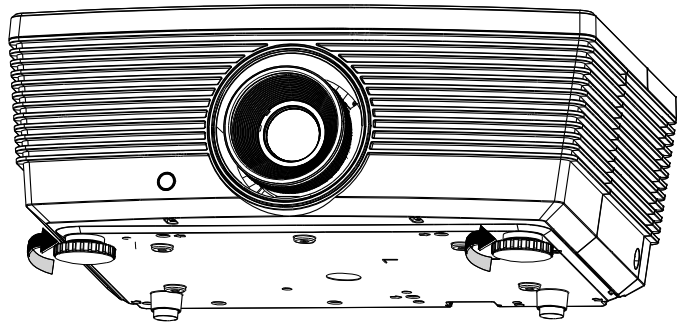

Adjusting Projected Image Position Using Shift

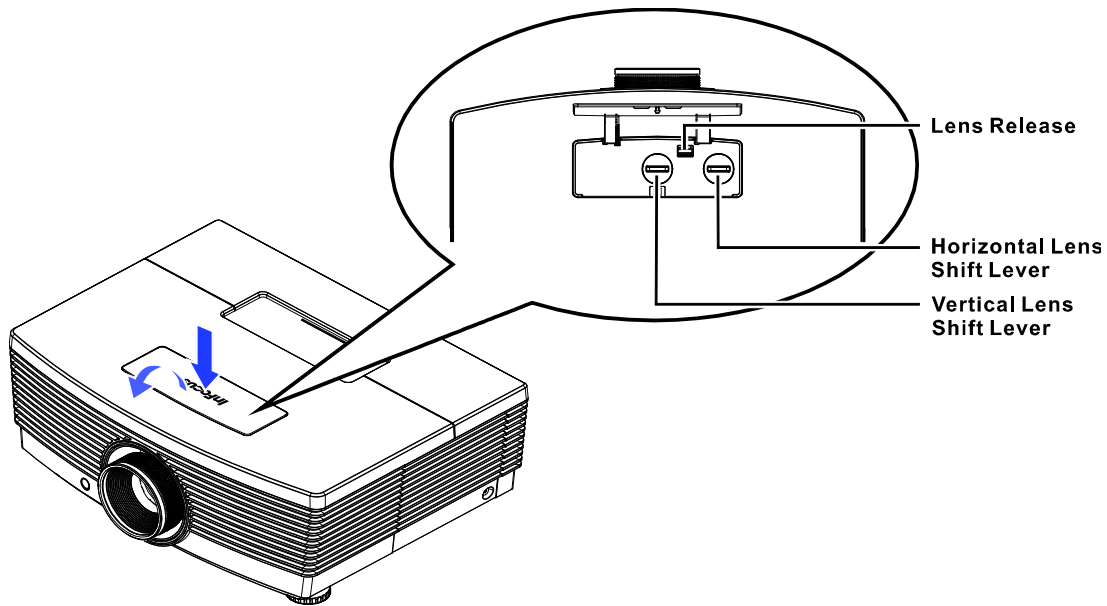

The Shift feature provides a lens shift function that can be used to adjust the position of the projected image either horizontally or vertically within the range detailed below.

Shift is a unique system that provides lens shift while maintaining a much higher ANSI contrast ratio than traditional lens shift systems.

Adjusting the vertical image position

The vertical image height can be adjusted between 10% and -70% offset for IN5316HDa (1080P); 0% and -60% offset for IN5312a (XGA); (offset = $(O/H) \times 100\%$, O: distance from bottom of image to center of lens). Note that the maximum vertical image height adjustment can be limited by the horizontal image position. Offset is the distance between the lens center line and the bottom of the image. The offset is positive if the lens center line is below the bottom of the image. The offset is negative if the lens center line is above the bottom of the image. For example it is not possible to achieve the maximum vertical image position height detailed above if the horizontal image position is at maximum. Please consult the Shift Range diagram below for further clarification.

For IN5316HDa (1080P)

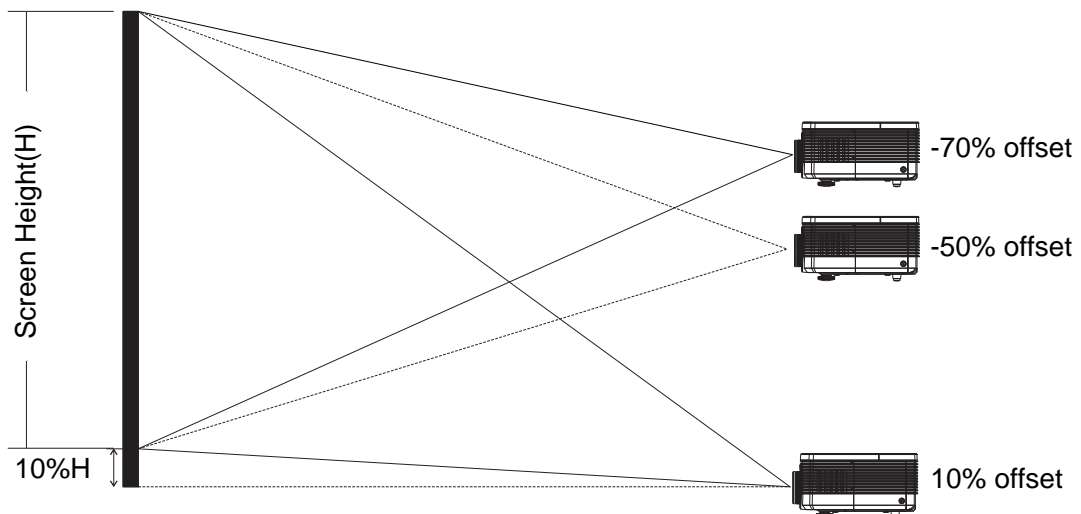

For IN5312a (XGA)

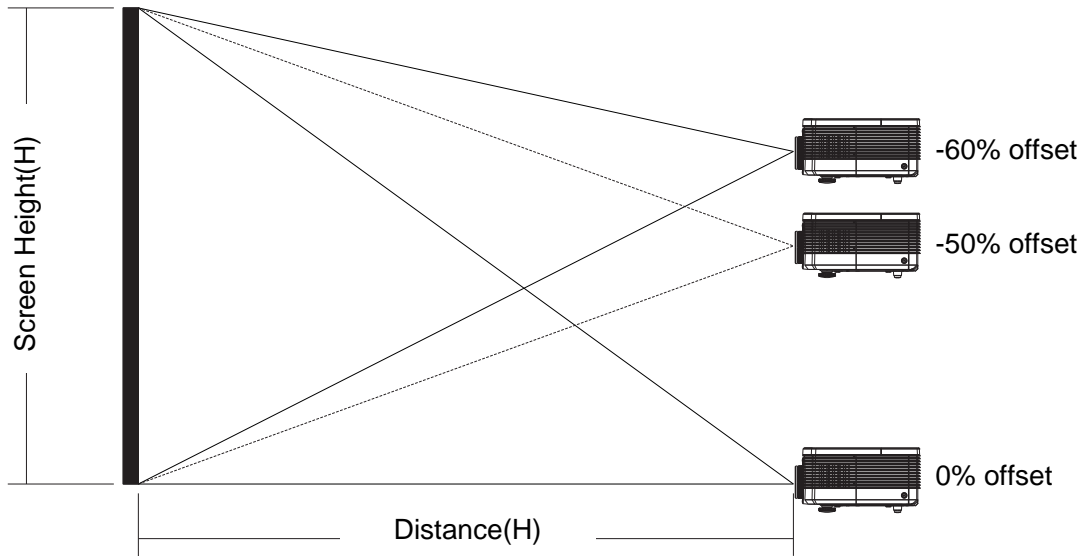

Adjusting the horizontal image position

With the lens in the center position the horizontal image position can be adjusted to the left or right by up to a maximum of 5% of the image width. Note that the maximum horizontal image height adjustment can be limited by the vertical image position. For example it is not possible to achieve the maximum horizontal image position if the vertical image position is at maximum. Please consult the Shift Range diagram below for further clarification.

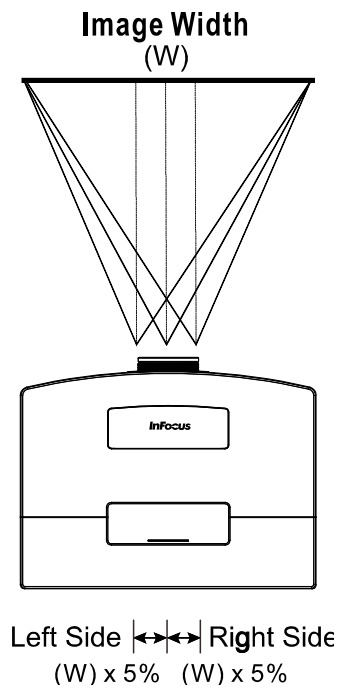

Shift Range Diagram

For IN5316HDa (1080P)

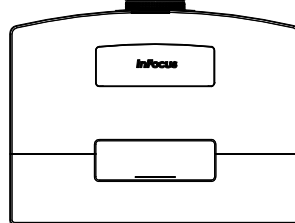
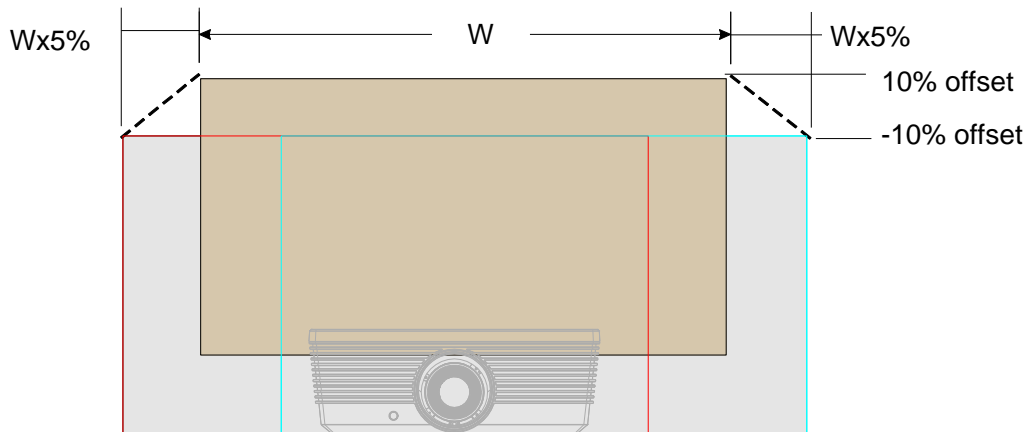

Max H image shift=10% offset
 Max W image shift=Wx5%
 When Wx5%, Max image shift=-10% offset
 When 10% offset, Max image shift=Wx0%

For IN5312a (XGA)

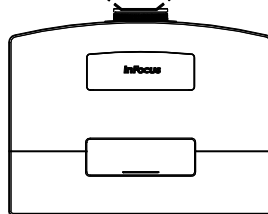
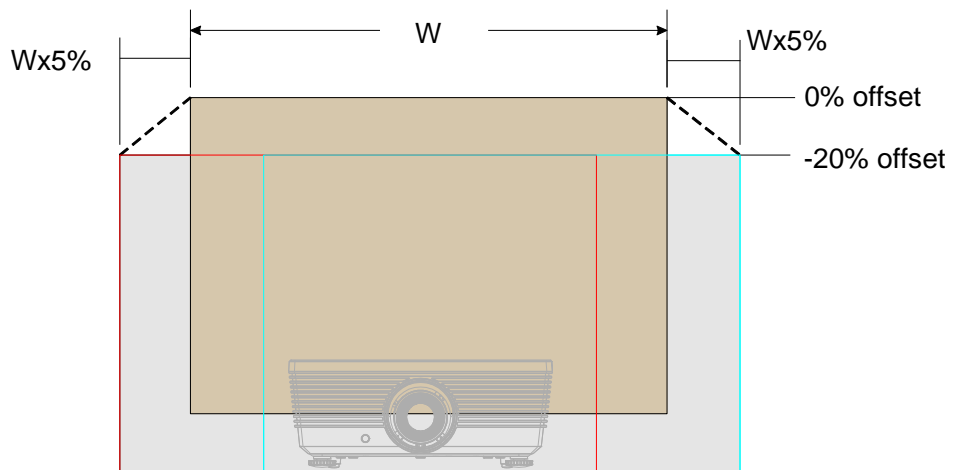

Max H image shift=0% offset
 Max W image shift=Wx5%
 When Wx5%, Max image shift=-20% offset
 When 0% offset, Max image shift=Wx0%

Adjusting Zoom, Focus and Keystone

1. Use the **Zoom** ring to resize the projected image and screen size.

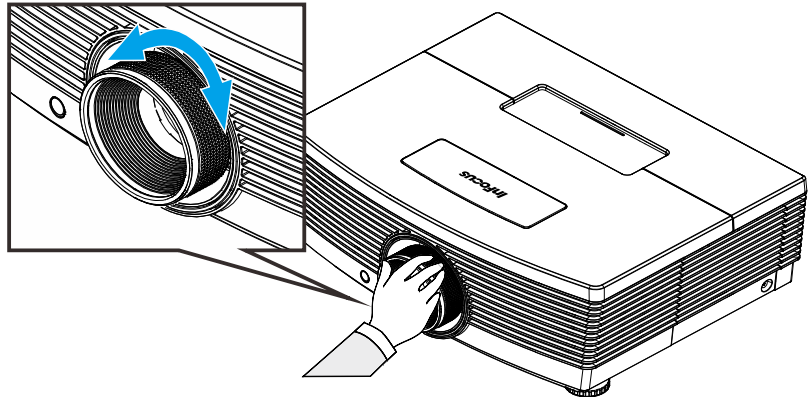

2. Use the **Focus** ring to sharpen the projected image.

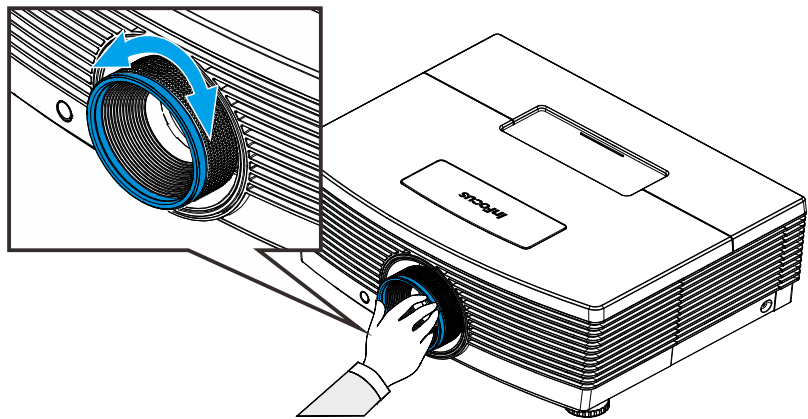

3. Use the **KEYSTONE** buttons (on the projector or the remote control) to correct image trapezoiding (wider top or bottom).

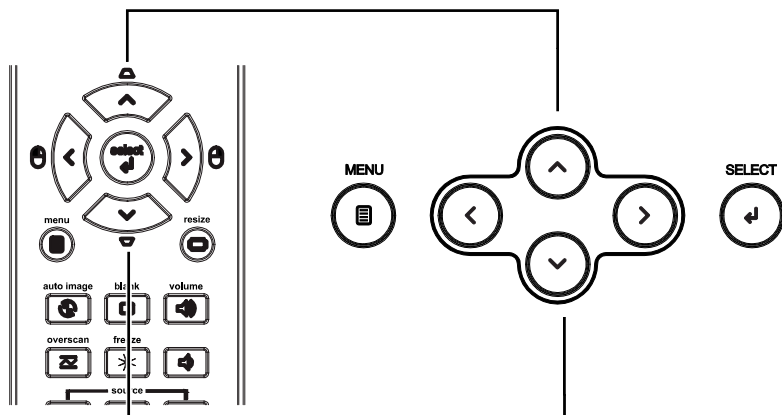

Remote control and OSD panel

4. The keystone control appears on the display.



Adjusting the Volume

1. Press the **Volume** buttons (on the projector or the remote control).

The volume control appears on the display.

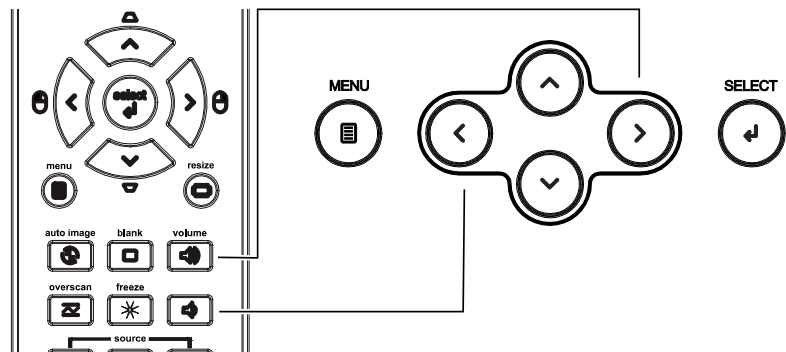

2. Use the **Vol +/-** buttons (on the projector or the remote control).



3. Press the **MUTE** button to turn off the audio (This feature is only available on the remote).



ON-SCREEN DISPLAY (OSD) MENU SETTINGS

OSD Menu Controls

The projector has an OSD that lets you make image adjustments and change various settings.

Navigating the OSD

You can use the remote control cursor buttons or the projector keypad to navigate and make changes to the OSD.

1. To enter the OSD, press the **MENU** button.
2. There are three menus. Press the cursor ◀▶ button to move through the menus.
3. Press the cursor ▲▼ button to move up and down in a menu.
4. Press ◀▶ to change values for settings.
5. Press **MENU** to access a different menu, leave a submenu or close the OSD.

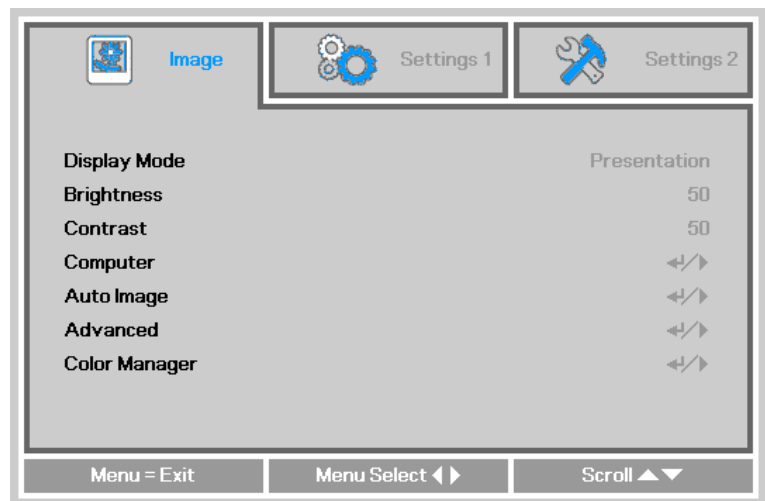

Note:

Depending on the video source, not all items in the OSD are available. For example, the **PC Detail Adjustment** item in the Display menu can only be modified when connected to a PC. Items that are not available cannot be accessed and are grayed out.

Setting the OSD Language

Set the OSD language to your preference before continuing.

1. Press the **MENU** button. Press the cursor ◀▶ button to navigate to **Settings 1**. Press the cursor ▲▼ button to move to the **Advanced 1** menu.

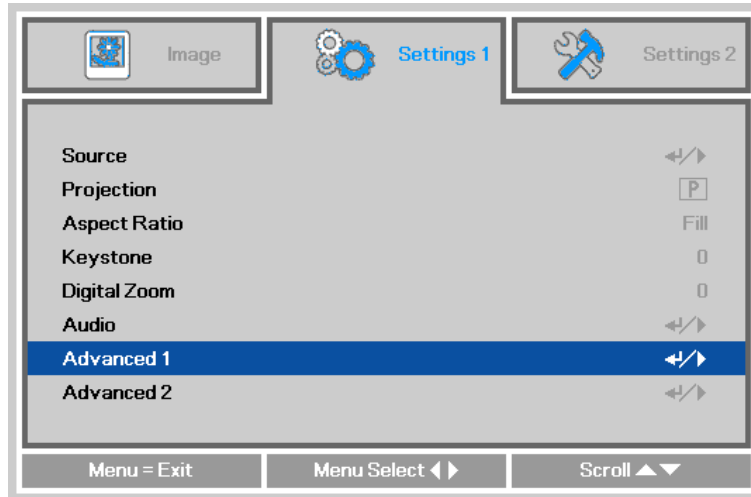

2. Press ◀ (Enter) / ▶ to enter the **Advanced 1** sub menu. Press the cursor ▲▼ button until **Language** is highlighted.

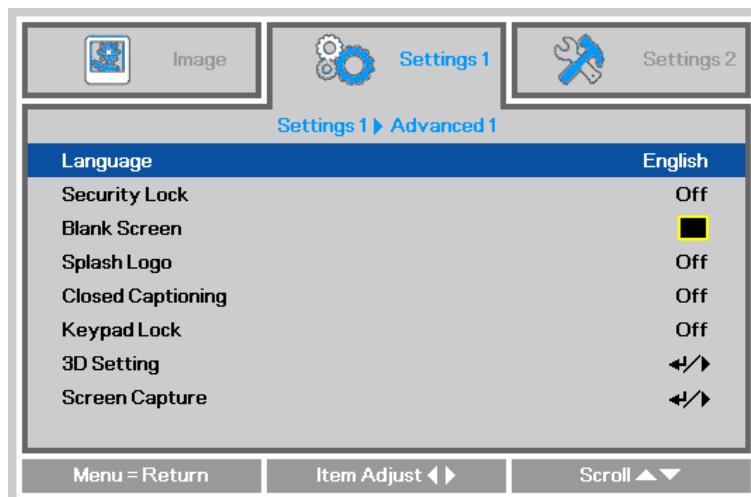

3. Press the cursor button until the language you want is highlighted.
4. Press the **MENU** button four times to close the OSD.

OSD Menu Overview

Use the following illustration to quickly find a setting or determine the range for a setting.

MAIN MENU	SUB MENU	SETTINGS	
Image	Display Mode	Presentation, Bright, Game, Movie, TV, sRGB, Blackboard, User	
	Brightness	0~100	
	Contrast	0~100	
	Computer	Horizontal Position	-50~50 (depending on Autolock)
		Vertical Position	-50~50 (depending on Autolock)
		Frequency	0~31
		Tracking	-5~5
	Auto Image		
	Advanced	Brilliant Color	0~10
		Sharpness	0~31
		Gamma	1.8, 2.0, 2.2, 2.4, B&W, Linear
		Color Temperature	Warm, Normal, Cold
		Video AGC	Off, On
		Video Saturation	0~100
	Color Manager	Video Tint	0~100
		Red	Hue, Saturation, Gain 0~100
		Green	Hue, Saturation, Gain 0~100
		Blue	Hue, Saturation, Gain 0~100
		Cyan	Hue, Saturation, Gain 0~100
		Magenta	Hue, Saturation, Gain 0~100
Yellow		Hue, Saturation, Gain 0~100	
White		Red, Green, Blue 0~100	

MAIN MENU	SUB MENU		SETTINGS		
Settings 1	Source	Source	Reference Input Source Select (IR/Keypad)		
	Projection		Normal, Real, Ceiling, Real+Ceiling		
	Aspect Ratio		Fill, 4:3, 16:9, Letter Box, Native, 2.35:1		
	Keystone		-40~40		
	Digital Zoom		-10~10		
	Audio	Volume		0~10	
		Mute		Off, On	
	Advanced 1	Language		English, Français, Deutsch, Español, Português, 簡體中文, 繁體中文, Italiano, Norsk, Svenska, Nederlands, Русский, Polski, Suomi, Ελληνικά, 한국어, Magyar, Čeština, العربية, Türkçe, Việt, 日本語, ភាសាខ្មែរ, فارسی, תירבע, Bahasa Indonesia, Dansk	
		Security Lock		Off, On	
		Blank Screen		Blank, Red, Green, Blue, White	
		Splash Logo		Std., Off, User	
		Closed Captioning		Off, On	
		KeypadLock		Off, On	
		3D Setting	3D		Off, DLP-Link, IR
			3D Sync Invert		Off, On
			3D Format		Frame Sequential, Top/Bottom, Side-By-Side, Frame Packing (3D Frame Packing HDMI source only)
		Screen Capture			
		Advanced 2	Test Pattern		None, RGB Ramp, Color Bars, Step Bars, Checkbox, Grid, Horizontal Line
	H Image Shift			-50~50	
	V Image Shift			-50~50	

MAIN MENU	SUB MENU	SETTINGS		
Settings 2	Auto Source	Off, On		
	No Signal Power Off	0~180		
	Auto Power On	Off, On		
	Lamp Mode	ECO , Normal, Boost		
	Reset All			
	Status	Active Source		
		Video Information		
		Lamp Hours (ECO, Normal, Boost)		
		Software Version		
		Serial Number		
	Advanced 1	Menu Position	Center, Down, Up, Left, Right	
		Translucent Menu	0%, 25%, 50%, 75%, 100%	
		Low Power Mode	Off, Low Power, On by Lan, VGA Out Mode	
		Fan Speed	Normal, High	
		Lamp Hour Reset		
		Projector ID	0-98	
		Network	Network State	Connect, Disconnect
			DHCP	Off, On
			IP Address	0~255, 0~255, 0~255. 0~255
			Subnet Mask	0~255, 0~255, 0~255. 0~255
			Gateway	0~255, 0~255, 0~255. 0~255
			DNS	0~255, 0~255, 0~255. 0~255
			Apply	Ok / Cancel
	Video Overscan	Off, On		
	Advanced 2	Sleep Timer	0~600	
		Source Filter	DVI	Disable, Enable
			HDMI	Disable, Enable
DisplayPort			Disable, Enable	
VGA1			Disable, Enable	
VGA2			Disable, Enable	
BNC			Disable, Enable	
Component Video			Disable, Enable	
S-Video			Disable, Enable	
Composite Video			Disable, Enable	

Image Menu



Attention !

When image options are changed, the Display Mode changes to User.

Press the **MENU** button to open the **OSD** menu. Press ◀▶ to move to the **Image Menu**. Press ▲▼ to move up and down in the **Image** menu. Press ◀▶ to enter and change values for settings.

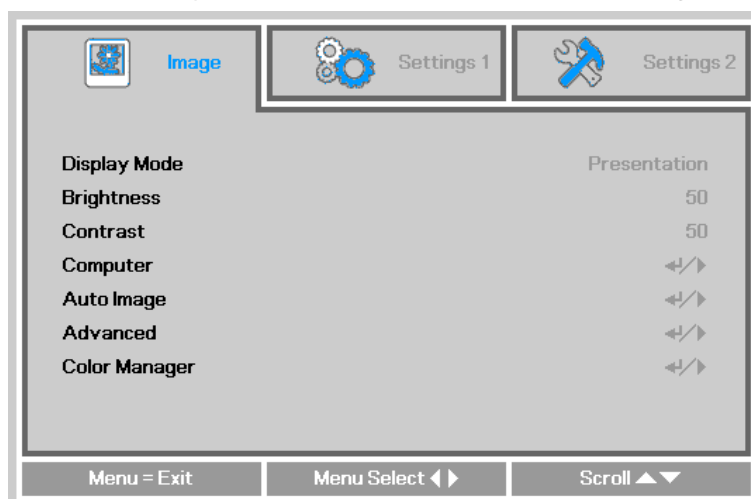

ITEM	DESCRIPTION
Display Mode	Press ◀▶ to enter and set the Display Mode.
Brightness	Press ◀▶ to enter and adjust the display brightness.
Contrast	Press ◀▶ to enter and adjust the display contrast.
Computer	Press ◀ (Enter) / ▶ to enter the Computer menu. See Computer Menu on page 26.
Auto Image	Press ◀ (Enter) / ▶ to automatically adjust phase, tracking, size and position.
Advanced	Press ◀ (Enter) / ▶ to enter the Advanced menu. See Advanced Feature on page 27.
Color Manager	Press ◀ (Enter) / ▶ to enter the color manager menu. See page 28 for more information on Color Manager .

Computer Menu

Press the **MENU** button to open the **OSD** menu. Press ◀▶ to move to the **Image** menu. Press ▲▼ to move to the **Computer** menu and then press **Enter** or ▶. Press ▲▼ to move up and down in the **Computer** menu.

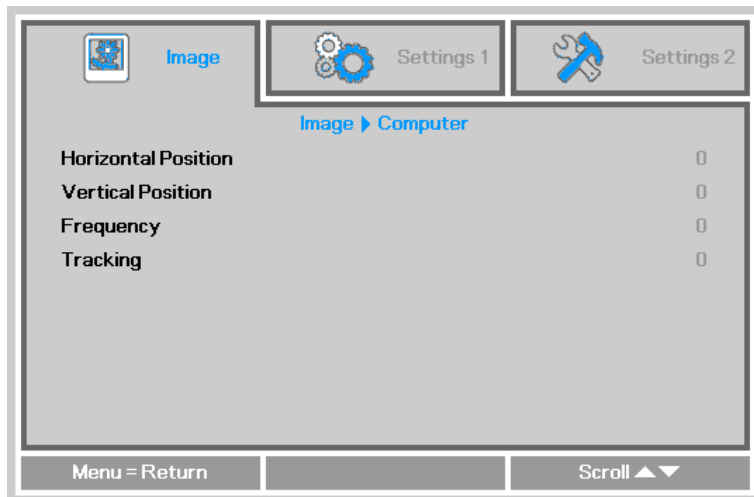

ITEM	DESCRIPTION
Horizontal Position	Press ◀▶ to enter and adjust the display position to left or right.
Vertical Position	Press ◀▶ to enter and adjust the display position to up or down.
Frequency	Press ◀▶ to enter and adjust the A/D sampling clock.
Tracking	Press ◀▶ to enter and adjust the A/D sampling dot.

Advanced Feature

Press the **Menu** button to open the **OSD** menu. Press ◀▶ to move to the **Image** menu. Press ▼▲ to move to the **Advanced** menu and then press **Enter** or ▶. Press ▼▲ to move up and down in the **Advanced** menu.

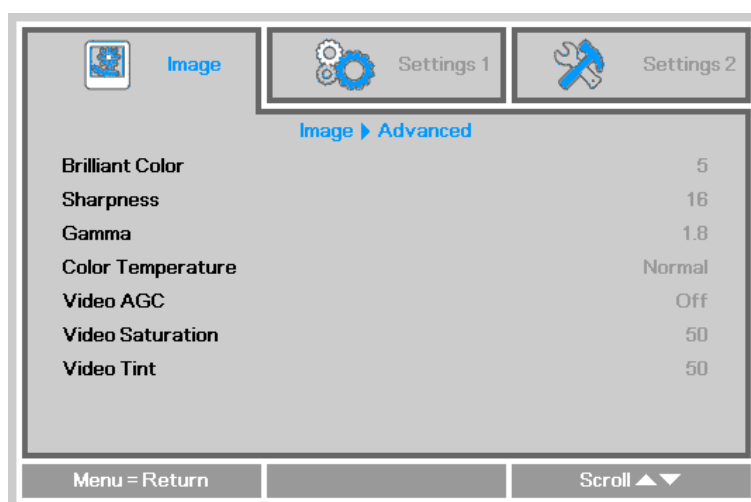

ITEM	DESCRIPTION
Brilliant Color	Press ◀▶ to enter and adjust the Brilliant Color value.
Sharpness	Press ◀▶ to enter and adjust the display sharpness.
Gamma	Press ◀▶ to enter and adjust the gamma correction of the display.
Color Temperature	Press ◀▶ to enter and adjust the color temperature.
Video AGC	Press ◀▶ to enter and enable or disable the Automatic Gain Control for video source.
Video Saturation	Press ◀▶ to enter and adjust the video saturation.
Video Tint	Press ◀▶ to enter and adjust the video tint/hue.

Color Manager

Press the **Menu** button to open the **OSD** menu. Press ◀▶ to move to the **Image** menu. Press ▼▲ to move to the **Color Manager** menu and then press **Enter** or ▶. Press ▼▲ to move up and down in the **Color Manager** menu.

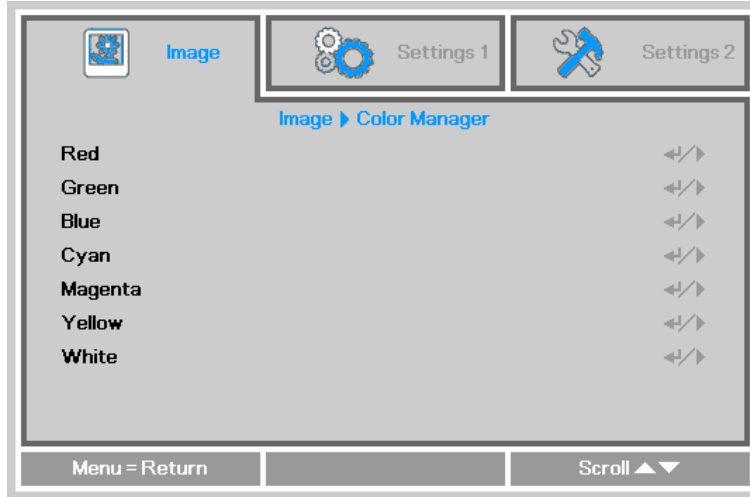

ITEM	DESCRIPTION
Red	Select to enter the Red Color Manager. Press ◀▶ to adjust the Hue, Saturation, and Gain.
Green	Select to enter the Green Color Manager. Press ◀▶ to adjust the Hue, Saturation, and Gain.
Blue	Select to enter the Blue Color Manager. Press ◀▶ to adjust the Hue, Saturation, and Gain.
Cyan	Select to enter the Cyan Color Manager. Press ◀▶ to adjust the Hue, Saturation, and Gain.
Magenta	Select to enter the Magenta Color Manager. Press ◀▶ to adjust the Hue, Saturation, and Gain.
Yellow	Select to enter the Yellow Color Manager. Press ◀▶ to adjust the Hue, Saturation, and Gain.
White	Select to enter the White Color Manager. Press ◀▶ to adjust the Red, Green, and Blue.

Settings 1 Menu

Press the **MENU** button to open the **OSD** menu. Press ◀▶ to move to the **Settings 1** menu. Press the ▲▼ to move up and down in the **Settings 1** menu. Press ◀▶ to enter and change values for settings.



ITEM	DESCRIPTION
Source	Press ◀ (Enter) / ▶ to enter the Source menu. Reference input Source select (IR / Keypad).
Projection	Press ◀▶ to enter and choose from four projection methods: Normal, Ceiling, Rear, and Rear + Ceiling.
Aspect Ratio	Press ◀▶ to enter and adjust the video aspect ratio.
Keystone	Press ◀▶ to enter and adjust the display keystone.
Digital Zoom	Press ◀▶ to enter and adjust the Digital Zoom menu.
Audio	Press ◀ (Enter) / ▶ to enter the Audio menu. See Audio on page 30.
Advanced 1	Press ◀ (Enter) / ▶ to enter the Advanced 1 menu. See Advanced 1 Feature on page 31.
Advanced 2	Press ◀ (Enter) / ▶ to enter the Advanced 2 menu. See Advanced 2 Feature on page 33.

Audio

Press the **Menu** button to open the **OSD** menu. Press ◀▶ to move to the **Settings 1** menu. Press ▼▲ to move to the **Audio** menu and then press **Enter** or ▶. Press ▼▲ to move up and down in the **Audio** menu.



ITEM	DESCRIPTION
Volume	Press ◀▶ to enter and adjust the audio volume.
Mute	Press ◀▶ to enter and turn on or off the speaker.

Advanced 1 Feature

Press the **Menu** button to open the **OSD** menu. Press ◀▶ to move to the **Settings 1** menu. Press ▲▼ to move to the **Advanced 1** menu and then press **Enter** or ▶. Press ▲▼ to move up and down in the **Advanced 1** menu. Press ◀▶ to enter and change values for setting.

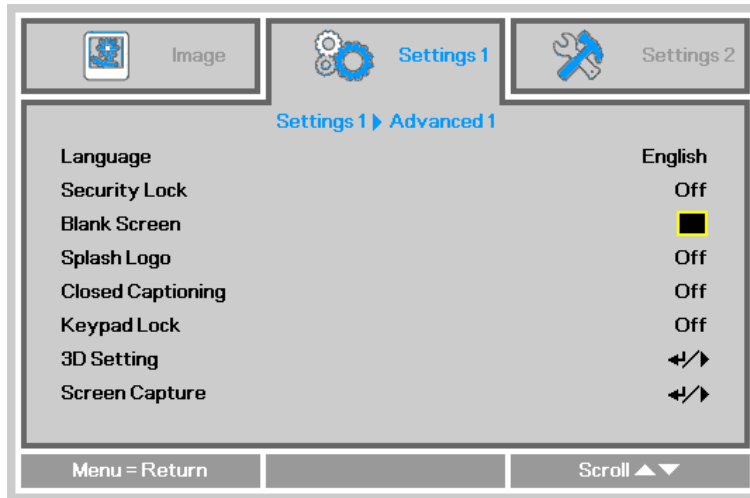

ITEM	DESCRIPTION
Language	Press ◀▶ to enter and select a different OSD language.
Security Lock	Press ◀▶ to enter and enable or disable the security lock function.
Blank Screen	Press ◀▶ to enter and select a different Blank Screen color.
Splash Logo	Press ◀▶ to enter and select splash logo on or off.
Closed Captioning	Press ◀▶ to enter and enable or disable Closed Captioning.
Keypad Lock	Press ◀▶ to enter and enable or disable the keypad keys.
3D Setting	Press ◀ (Enter) / ▶ to enter the 3D menu. See page 32 for more information on 3D Setting .
Screen Capture	Press ◀ (Enter) / ▶ to capture an image of your screen and display it during the next power-up cycle.

Note:

To enjoy the 3D function, first enable the Play Movie in 3D setting found in your DVD device under the 3D Disc Menu.

3D Setting

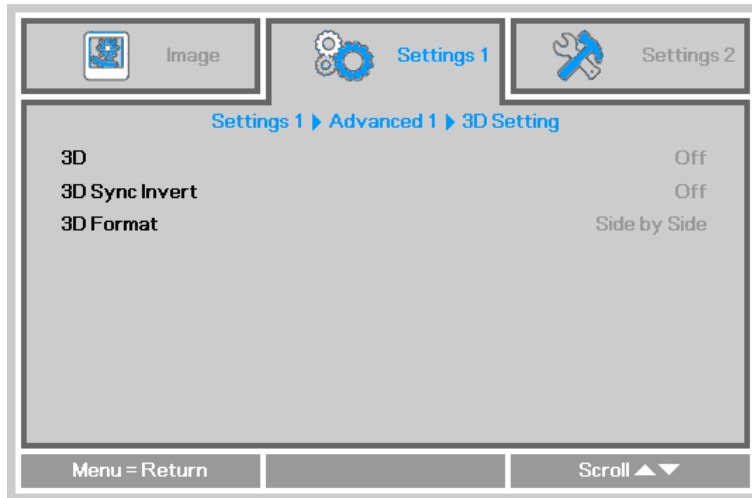

ITEM	DESCRIPTION
3D	Press ◀▶ to enter and select a different 3D mode.
3D Sync Invert	Press ◀▶ to enter and enable or disable 3D Sync Invert.
3D Format	Press ◀▶ to enter and enable or disable different 3D Formats.

Note:

1. By default, the 3D OSD menu options will be grayed out until a 3D source is detected. When a 3D source is detected, the menu options will become available.
2. Use 3D glasses to view a 3D image.
3. You need 3D content from a 3D DVD or 3D media file.
4. You need to enable the 3D source (some 3D DVD content may have a 3D On/Off selection feature).
5. You need DLP link 3D or IR 3D shutter glasses. With IR 3D shutter glasses, you need to install a driver on your PC and connect a USB emitter.
6. Make sure to choose the 3D mode which matches the type of glasses you are using (DLP Link or IR 3D).
7. Power on the glasses. Glasses normally have a power On/Off switch. Follow the configuration instructions which came with your glasses to finish the setup process.

Advanced 2 Feature

Press the **Menu** button to open the **OSD** menu. Press ◀▶ to move to the **Settings 1** menu. Press ▲▼ to move to the **Advanced 2** menu and then press **Enter** or ▶. Press ▲▼ to move up and down in the **Advanced 2** menu. Press ◀▶ to enter and change values for setting.

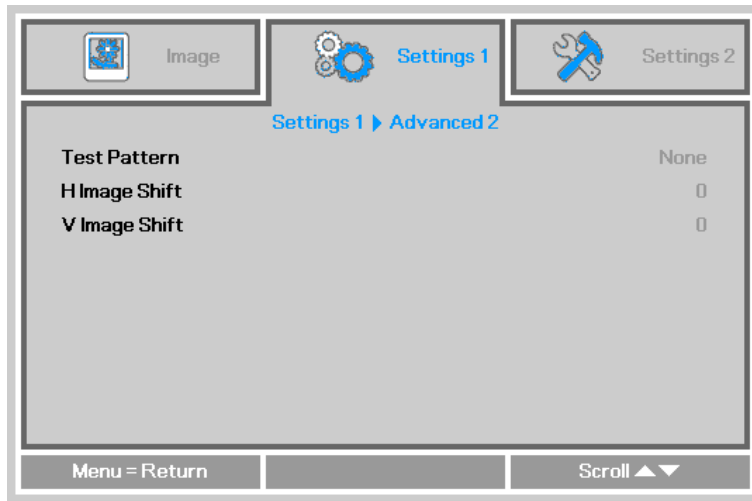

ITEM	DESCRIPTION
Test Pattern	Press ◀▶ to enter and select an internal test pattern.
H Image Shift	Press ◀▶ to enter and select H Image Shift.
V Image Shift	Press ◀▶ to enter and select V Image Shift.

Settings 2 Menu

Press the **MENU** button to open the **OSD** menu. Press ◀▶ to move to the **Settings 2** menu. Press ▲▼ to move up and down in the **Settings 2** menu.

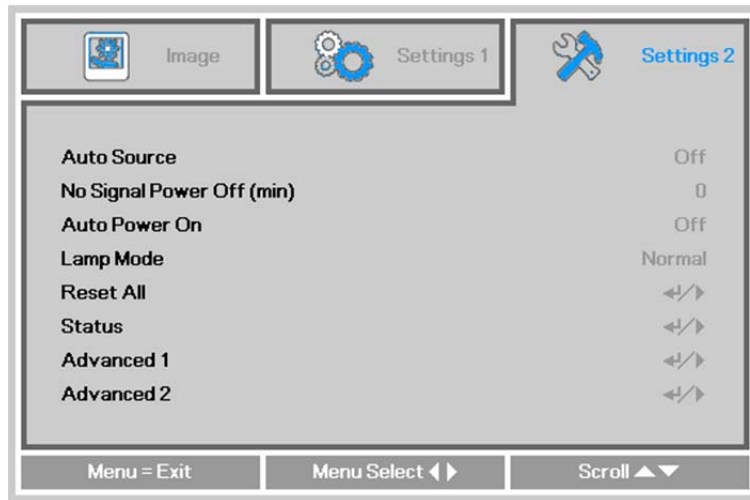

ITEM	DESCRIPTION
Auto Source	Press ◀▶ to enter and enable or disable automatic source detection.
No Signal Power Off (min.)	Press ◀▶ to enter and enable or disable automatic shutdown of the lamp when no signal is detected.
Auto Power On	Press ◀▶ to enter and enable or disable automatic power On when AC power is supplied.
Lamp Mode	Press ◀▶ to enter and select the lamp mode for higher brightness or lower brightness to save lamp life.
Reset All	Press ⏏ (Enter) / ▶ to reset all settings to default values.
Status	Press ⏏ (Enter) / ▶ to enter the Status menu. See page 35 for more information on Status .
Advanced 1	Press ⏏ (Enter) / ▶ to enter the Advanced 1 menu. See Advanced 1 Feature on page 36.
Advanced 2	Press ⏏ (Enter) / ▶ to enter the Advanced 2 menu. Advanced 2 Feature on page 39

Status

Press ▲▼ to move up and down in the **Settings 2** menu. Select the **Status** menu and press **Enter** or ► to enter.

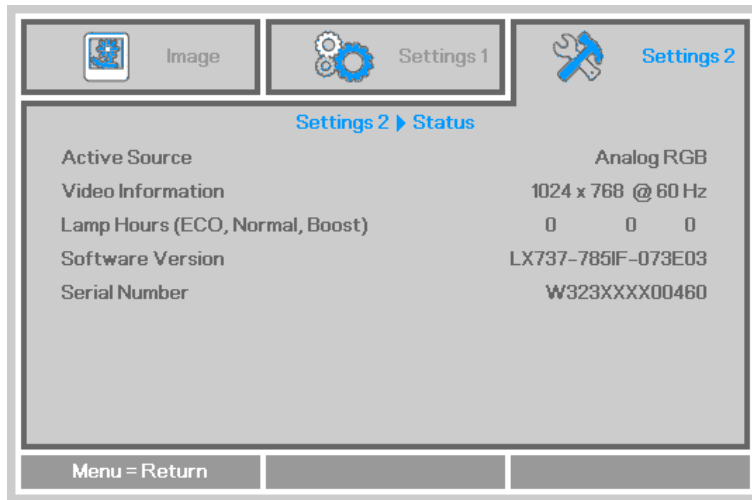

ITEM	DESCRIPTION
Active Source	Displays the active source.
Video Information	Displays resolution/video information for RGB source and color standard for Video source.
Lamp Hours	Lamp hour used information is displayed (ECO, Normal, Boost).
Software Version	Displays the system software version.
Serial Number	Displays the serial number of this projector.

Advanced 1 Feature

Press the **Menu** button to open the **OSD** menu. Press ◀▶ to move to the **Settings 2** menu. Press ▲▼ to move to the **Advanced 1** menu and then press **Enter** or ▶. Press ▲▼ to move up and down in the **Advanced 1** menu. Press ◀▶ to enter and change values for setting.

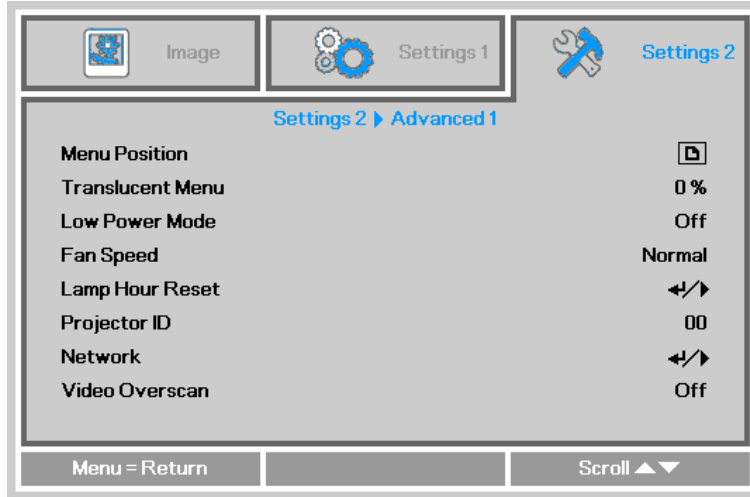

ITEM	DESCRIPTION
Menu Position	Press ◀▶ to enter and select different OSD location.
Translucent Menu	Press ◀▶ to enter and select OSD background translucent level.
Low Power Mode	Press ◀▶ to enter and select Low Power Mode : Off, Low Power, On by Lan or VGA Out Mode. Low Power mode uses less than 0.5W of power in standby mode and disables LAN functionality. If you want to be able to turn on the projector via LAN and use less than 6W of power in standby mode, choose On by LAN instead.
Fan Speed	Press ◀▶ to enter and toggle between Normal and High fan speeds. Note: We recommend selecting high speed in high temperatures, high humidity, or high altitude (higher than 1500m/4921ft) areas.
Lamp Hour Reset	After replacing the lamp, this item should be reset. See page 37 for more information on Lamp Hour Reset .
Projector ID	Press ◀▶ to enter and adjust a two digit projector ID from 00 through 98.
Network	Press ◀ (Enter) / ▶ to enter the Network menu. See page 37 for more information on Network .
Video Overscan	Press ◀▶ to enter and turn Video Overscan on or off.

Lamp Hour Reset



Please refer to [Resetting the Lamp Timer](#) on page 44 to reset the lamp hour counter.

Network

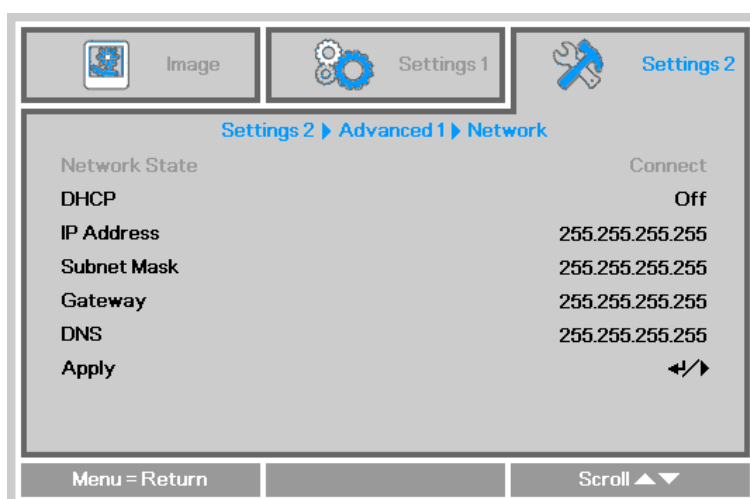

ITEM	DESCRIPTION
Network State	Displays the network connection status.
DHCP	Press ◀▶ to turn DHCP On or Off. Note: If you select DHCP Off, complete the IP Address, Subnet Mask, Gateway, and DNS fields.
IP Address	Enter a valid IP address if DHCP is turned off.
Subnet Mask	Enter a valid Subnet Mask if DHCP is turned off.
Gateway	Enter a valid Gateway address if DHCP is turned off.
DNS	Enter a valid DNS name if DHCP is turned off.
Apply	Press ◀ (Enter) / ▶ to confirm settings.

Controlling the projector remotely

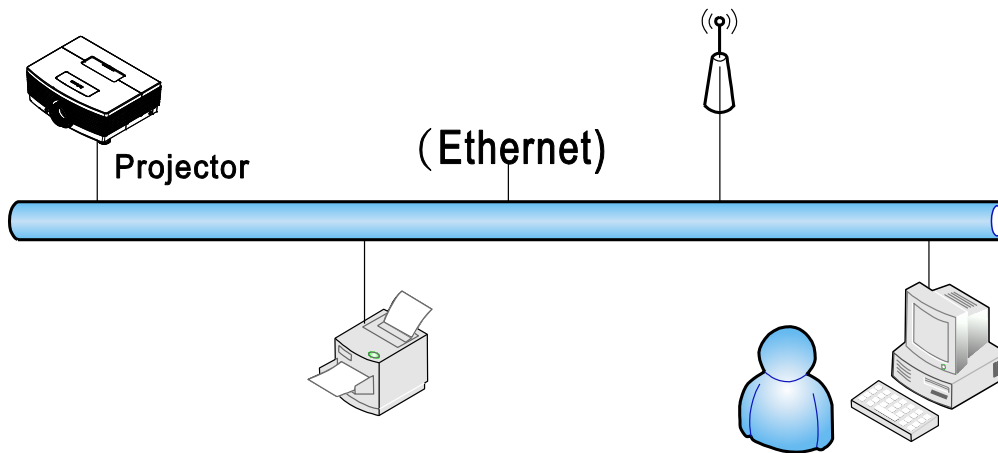

To control your projector remotely, use one of the supported external devices listed below, or use RS232 using a TelNet utility, such as HyperTerminal.

- ★ Crestron is a registered trademark of Crestron Electronics, Inc. of the United States.
- ★ Extron is a registered trademark of Extron Electronics, Inc. of the United States.
- ★ AMX is a registered trademark of AMX LLC of the United States.
- ★ PJLink applied for trademark and logo registration in Japan, the United States of America, and other countries by JBMIA.

Supported External Devices

This projector supports specified Crestron Electronics controller commands and related software (ex, RoomView ®).

<http://www.crestron.com/>

This projector supports AMX (Device Discovery).

<http://www.amx.com/>

This projector supports Extron device(s).

<http://www.extron.com/>

This projector supports all commands of PJLink Class1 (Version 1.00).

<http://pjlink.jbmia.or.jp/english/>

For detailed information about the diverse types of external devices which can be connected to the LAN/RJ45 port to control the projector, as well as related control commands, go to www.infocus.com/support.

Advanced 2 Feature

Press the **Menu** button to open the **OSD** menu. Press ◀▶ to move to the **Settings 2** menu. Press ▲▼ to move to the **Advanced 2** menu and then press **Enter** or ▶. Press ▲▼ to move up and down in the **Advanced 2** menu. Press ◀▶ to enter and change values for setting.

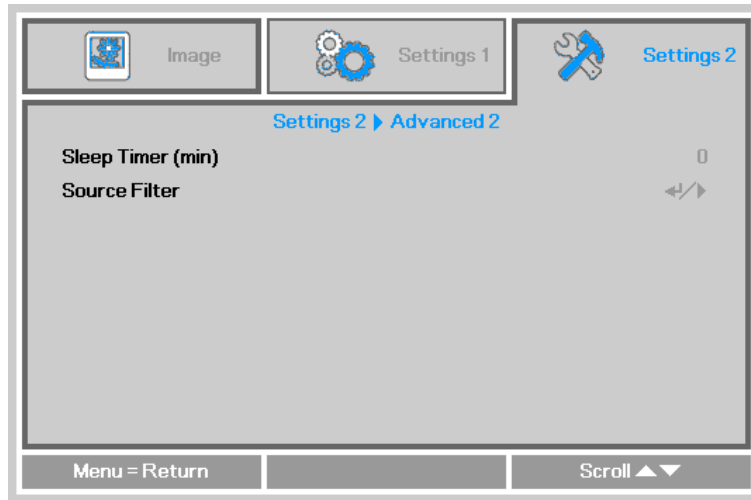

ITEM	DESCRIPTION
Sleep Timer (min)	Press ◀▶ to enter and set Sleep timer. The projector automatically turns off after the preset period of time.
Source Filter	Press ◀ (Enter) / ▶ to enter the Source Filter menu. See page 40 for more information on Source Filter .

Source Filter

Press the **ENTER** button to enter the **Source Filter** sub menu.

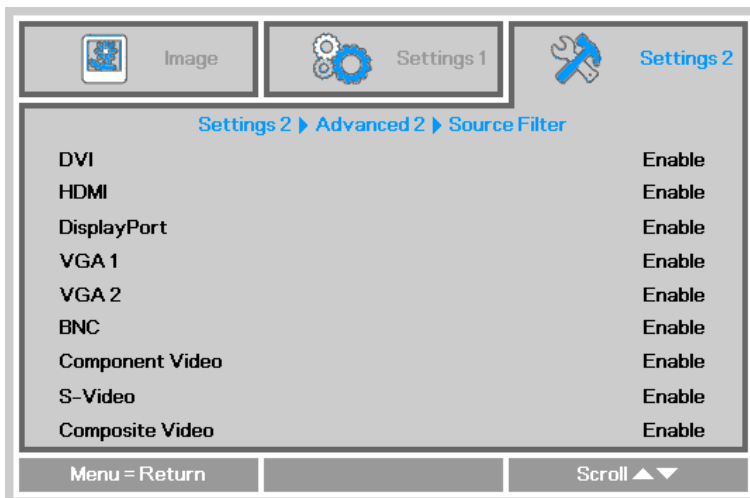

ITEM	DESCRIPTION
DVI	Press ◀▶ to enter and enable or disable the DVI source.
HDMI	Press ◀▶ to enter and enable or disable the HDMI source.
DisplayPort	Press ◀▶ to enter and enable or disable the DisplayPort source.
VGA1	Press ◀▶ to enter and enable or disable the VGA1 source.
VGA2	Press ◀▶ to enter and enable or disable the VGA2 source.
BNC	Press ◀▶ to enter and enable or disable the BNC source.
Component Video	Press ◀▶ to enter and enable or disable the Component Video source.
S-Video	Press ◀▶ to enter and enable or disable the S-Video source.
Composite Video	Press ◀▶ to enter and enable or disable the Composite Video source.

MAINTENANCE AND SECURITY

Replacing the Projection Lamp

The projection lamp should be replaced when it burns out. Be sure to use the InFocus lamp module designed for this projector. You can order new lamps from www.infocusstore.com (in select areas), your retailer or your dealer. Only genuine InFocus lamps are tested for use in this projector. Use of non InFocus lamps may cause electrical shock and fire, and may void the projector warranty. InFocus is not liable for the performance, safety or certification of any other lamps.



Warning:

- *The projector uses a high-pressure mercury glass lamp. The lamp may fail prematurely, or it may rupture with a popping sound if jolted, scratched, or handled while hot. The risk of lamp failure or rupture also increases as the lamp age increases; please replace the lamp when you see the "Replace Lamp."*
- *Do not touch or block the projector lens with any objects as this can damage the projector lens. Scratches, gouges and other lens damage are not covered by the product warranty.*
- *Unplug the power cord before replacing the lamp.*
- *Do not drop the lamp module. The glass may shatter and cause injury.*
- *Do not touch the glass surface of the lamp module. Fingerprints can obscure projection sharpness and may cause the glass to shatter.*
- *Be extremely careful when removing the lamp housing. In the unlikely event that the lamp ruptures, small glass fragments may be generated. The lamp module is designed to contain most of these fragments, but use caution when removing it.*
- *Before replacing a ruptured lamp, clean the lamp compartment and dispose of cleaning materials. Wash hands after lamp replacement.*
- *When replacing the lamp while the projector is ceiling-mounted, wear protective eyewear to prevent eye injury. Hg – Lamp contains mercury. Manage in accordance with local disposal laws. See www.lamprecycle.org.*
- *Be sure to turn off and unplug the projector at least 60 minutes before replacing the lamp. Failure to do so could result in a severe burn.*

- 1.** Switch off the power to the projector by pressing the POWER button twice.
- 2.** Allow the projector to cool down at least 60 minutes.
- 3.** Disconnect the power cord.

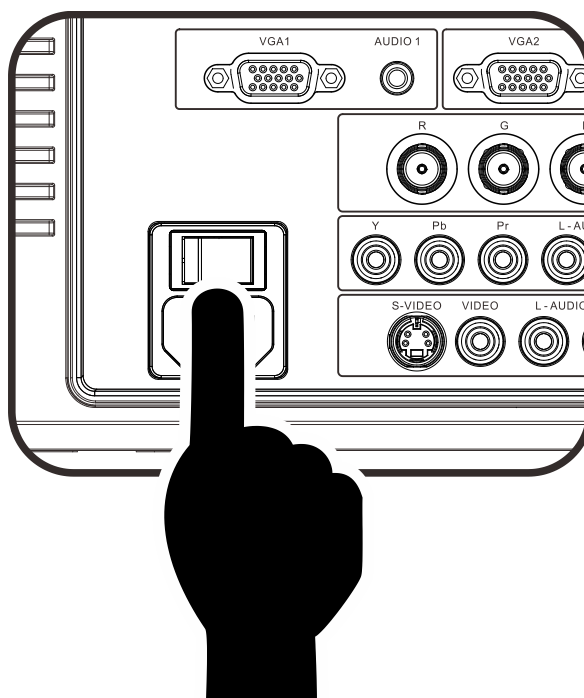

- 4.** Loosen the captive screw on the lamp cover.

- 5.** Pull up and remove the cover.

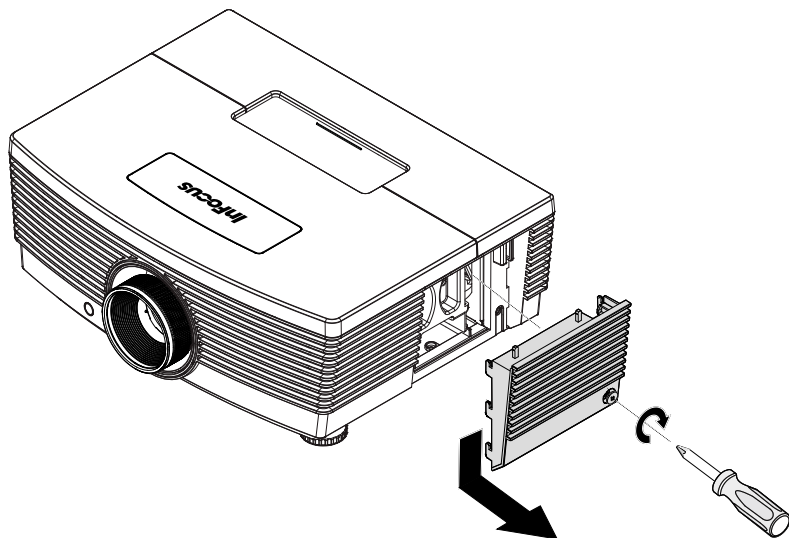

- 6.** Use a screwdriver to loosen the two captive screws from the lamp module.

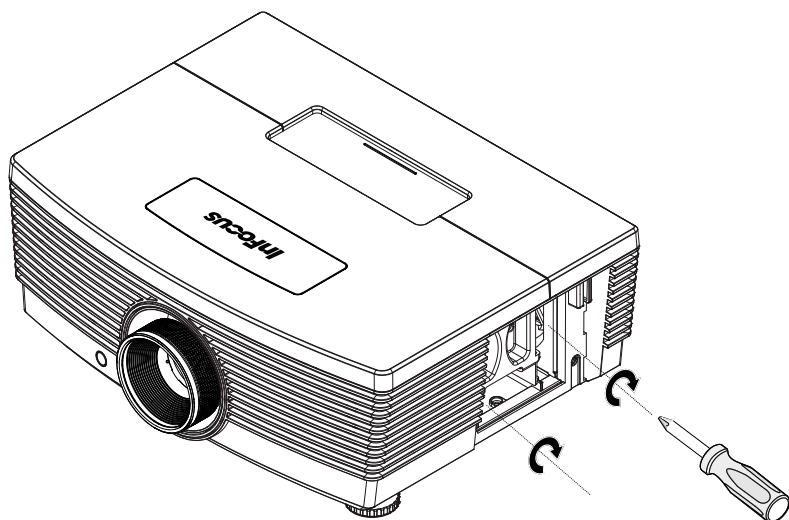

- 7.** Pull out the lamp module.

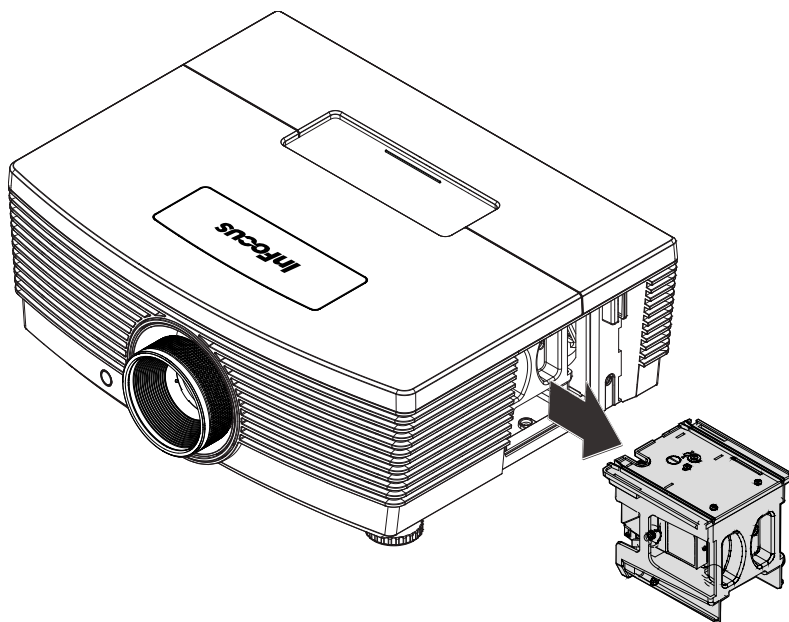

- 8.** Reverse steps 1 to 7 to install the new lamp module. While installing, align the lamp module with the connector and ensure it is level to avoid damage.

Note:

The lamp module must sit securely in place and the lamp connector must be connected properly before tightening the screws.

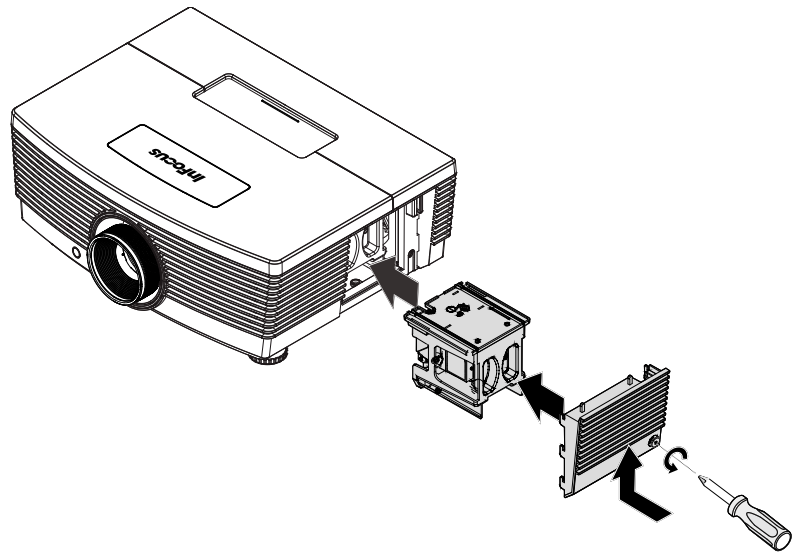

Resetting the Lamp Timer

After replacing the lamp, you should reset the lamp hour timer to zero. Refer to the following:

1. Press the **MENU** button to open the OSD menu.
2. Press the **◀▶** buttons to move to the **Settings 2** menu. Press the **▼** button to move down to **Advanced 1** and press enter.
3. Press the **▼▲** buttons to move down to **Lamp Hour Reset**.
4. Press the **↵** (Enter) or **▶** button. A message screen appears.
5. Press the **▼▲◀▶** buttons in sequence to reset the lamp timer.
6. Press the **MENU** button to return to **Settings 2**.

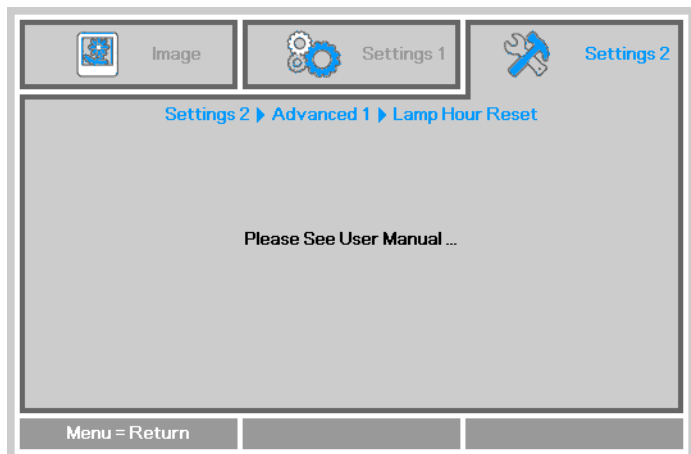
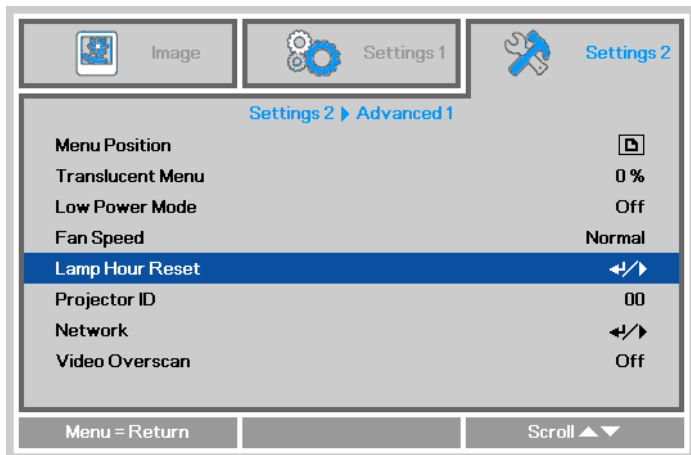
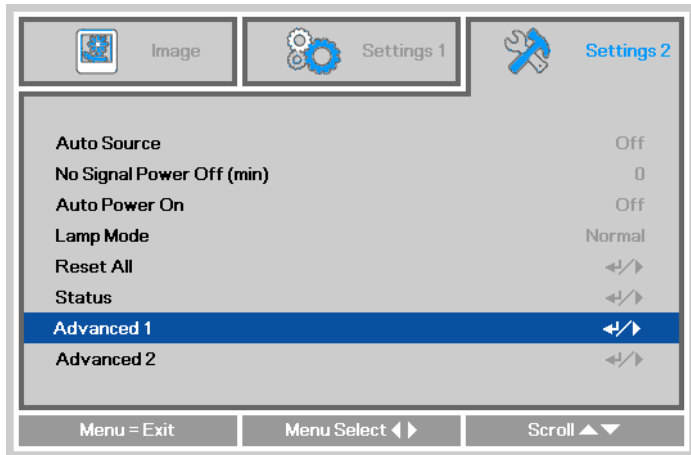

Cleaning the Projector

Cleaning the projector to remove dust and grime will help ensure trouble-free operation.

**Warning:**

1. Be sure to turn off and unplug the projector at least 60 minutes before cleaning. Failure to do so could result in a severe burn.
2. Use only a dampened cloth when cleaning. Do not allow water to enter the ventilation openings on the projector.
3. If a little water gets into the projector interior while cleaning, leave unplugged in a well-ventilated room for several hours before using.
4. If a lot of water gets into the projector interior when cleaning, have the projector serviced.

Cleaning the Lens

You can purchase optic lens cleaner from most camera stores. Refer to the following to clean the projector lens.

1. Apply a little optic lens cleaner to a clean soft cloth. (Do not apply the cleaner directly to the lens.)
2. Lightly wipe the lens in a circular motion.

**Caution:**

1. Do not use abrasive cleaners or solvents.
2. To prevent discoloration or fading, avoid getting cleaner on the projector case.

Cleaning the Case

Refer to the following to clean the projector case.

1. Wipe off dust with a clean dampened cloth.
2. Moisten the cloth with warm water and mild detergent, and then wipe the case.
3. Rinse all detergent from the cloth and wipe the projector again.

**Caution:**

To prevent discoloration or fading of the case, do not use abrasive alcohol-based cleaners.

Common Problems and Solutions

These guidelines provide tips to deal with problems you may encounter while using the projector. If the problem remains unsolved, contact InFocus at www.infocus.com/support.

Often the problem is traced to something as simple as a loose connection. Check the following before proceeding to problem-specific solutions.

- *Use another electrical device to confirm that the electrical outlet is working.*
- *Ensure the projector is turned on.*
- *Ensure all connections are securely attached.*
- *Ensure the attached device is turned on.*
- *Ensure a connected PC is not in standby mode.*
- *Ensure a connected notebook computer is configured for an external display. (This is usually done by pressing a Fn-key combination on the notebook. Go to www.infocus.com/support and the Learn tab to review the Laptop Activation chart.)*

Tips for Troubleshooting

In each problem-specific section, try the steps in the order suggested. This may help you to solve the problem more quickly.

Try to pinpoint the problem and avoid replacing non-defective parts.

For example, if you replace batteries and the problem remains, put the original batteries back and go to the next step.

Keep a record of the steps you take when troubleshooting. The information may be useful when calling Technical Support and obtaining service.

LED Error Messages

Error Code Messages	PWR LED	TEMP LED	READY LED
Overheating	Off	Solid Red	Off
Thermal break	Flashing Red 4x	Off	Off
Lamp strike fail	Flashing Red 5x	Off	Flashing Red 1x
Lamp Short circuit in output detected	Flashing Red 5x	Off	Flashing Red 2x
Lamp End of lamp life detected	Flashing Red 5x	Off	Flashing Red 3x
Lamp did not ignite	Flashing Red 5x	Off	Flashing Red 4x
Fan 1 error	Flashing Red 6x	Off	Flashing Red 1x
Fan 2 error	Flashing Red 6x	Off	Flashing Red 2x
Fan 3 error	Flashing Red 6x	Off	Flashing Red 3x
Fan 4 error	Flashing Red 6x	Off	Flashing Red 4x
Case open	Flashing Red 7x	Off	Off
DMD fail	Flashing Red 8x	Off	Off
Color wheel fail	Flashing Red 9x	Off	Off
Ballast Communication fail	Flashing Red 5x	Off	Flashing Red 10x

In the event of an error, please disconnect the AC power cord and wait for one (1) minute before restarting the projector. If the PWR or READY LED is still blinking or the TEMP LED is lit, contact InFocus Technical Support at www.infocus.com/support.

Image Problems

Problem: No image appears on the screen

1. Verify the settings on your notebook or desktop PC.
2. Turn off all equipment and power up again in the correct order.
3. Many laptops do not automatically turn on their external video port when a projector is connected. Usually a key combination like **FN + F8** or CRT/LCD key turns the external display on and off. Locate a function key labeled CRT/LCD or function key with a monitor symbol. Press FN and the labeled function key simultaneously.

Problem: The image is blurred

1. Adjust the **Focus** on the projector.
2. Press the **Auto** button on the remote control.
3. Ensure the projector-to-screen distance is within the projection range. (Within 7m/23' for the standard lens; within 20m/66' for the long lens and within 3m/10' for the short lens).
4. Check that the projector lens is clean.

Problem: The image is wider at the top or bottom (trapezoid effect)

1. Position the projector so it is as perpendicular to the screen as possible.
2. Use the **Keystone** buttons on the remote control or projector to correct the problem.

Problem: The image is reversed

Check the **Projection** setting on the **Settings 1** menu of the OSD.

Problem: The image is streaked

1. Set the **Frequency** and **Tracking** settings on the **Image->Computer** menu of the OSD to the default settings.
2. To ensure the problem is not caused by a connected PC's video card, connect to another computer.

Problem: The image is flat with no contrast

Adjust the **Contrast** setting on the **Image** menu of the OSD.

Problem: The color of the projected image does not match the source image.

Adjust the **Color Temperature** and **Gamma** settings on the **Image->Advanced** menu of the OSD.

Lamp Problems

Problem: There is no light from the projector

1. Check that the power cable is securely connected.
2. Ensure the power source is good by testing with another electrical device.
3. Restart the projector in the correct order and check that the PWR LED is on.
4. If you have replaced the lamp recently, try resetting the lamp connections.
5. Replace the lamp module.
6. Put the old lamp back in the projector and have the projector serviced.

Problem: The lamp goes off

1. Power surges can cause the lamp to turn off. Unplug and re-plug the power cord and press the Power button.
2. If the lamp still does not ignite, unplug the projector and allow it to cool for 60 minutes. Replace the lamp.
3. If a new lamp does not resolve the issue, put the old lamp back into the projector and arrange to have the projector repaired.

Remote Control Problems

Problem: The projector does not respond to the remote control

1. Direct the remote control towards remote sensor on the projector.
2. Ensure the path between remote and sensor is not obstructed.
3. Turn off any fluorescent lights in the room.
4. Check the battery polarity.
5. Replace the batteries.
6. Turn off other infrared-enabled devices in the vicinity.
7. Replace the remote control.

Audio Problems

Problem: There is no sound

1. Adjust the volume on the remote control.
2. Adjust the volume of the audio source.
3. Check the audio cable connection.
4. Disconnect audio out cable.
5. Test the source audio output with other speakers.
6. Have the projector serviced.

Problem: The sound is distorted

1. Check the audio cable connection.
2. Test the source audio output with other speakers.
3. Have the projector serviced.

Having the Projector Serviced

If you are unable to solve the problem contact InFocus Technical Support at www.infocus.com/support. If your projector needs repair, pack the projector in the original carton and include the return authorization number on the outside of the box.

HDMI Q & A

Q. What is the difference between a “Standard” HDMI cable and a “High-Speed” HDMI cable?

Recently, HDMI Licensing, LLC announced that cables would be tested as Standard or High-Speed cables.

Standard (or “category 1”) HDMI cables have been tested to perform at speeds of 75Mhz or up to 2.25Gbps, which is the equivalent of a 720p/1080i signal.

High Speed (or “category 2”) HDMI cables have been tested to perform at speeds of 340Mhz or up to 10.2Gbps, which is the highest bandwidth currently available over an HDMI cable and can successfully handle 1080p signals including those at increased color depths and/or increased refresh rates from the Source. High-Speed cables are also able to accommodate higher resolution displays, such as WQXGA cinema monitors (resolution of 2560 x 1600).

Q. How do I run HDMI cables longer than 10 meters?

There are many HDMI Adapters working on HDMI solutions that extend a cable’s effective distance from the typical 10 meter range to much longer lengths. These companies manufacture a variety of solutions that include active cables (active electronics built into cables that boost and extend the cable’s signal), repeaters, amplifiers as well as CAT5/6 and fiber solutions.

Q. How can I tell if a cable is an HDMI certified cable?

All HDMI products are required to be certified by the manufacturer as part of the HDMI Compliance Test Specification. However, there may be instances where cables bearing the HDMI logo are available but have not been properly tested. HDMI Licensing, LLC actively investigates these instances to ensure that the HDMI trademark is properly used in the market. We recommend that consumers buy their cables from a reputable source and a company that is trusted.

For more detailed information, go to: <http://www.hdmi.org/learningcenter/faq.aspx#49>

SPECIFICATIONS**Specifications**

Model	IN5312a	IN5316HDa
Display type	TI DMD XGA 0.7"	TI DMD 1080P 0.65"
Native Resolution	1024x768	1920x1080
Projection distance (standard lens)	1.5 meters ~ 7 meters (4.92 ft ~ 22.97 ft)	
Projection screen size (standard lens)	37.3" ~ 215" (95cm ~ 546cm)	35.1"~205" (89cm~521cm)
Projection lens	Manual Focus/Manual Zoom	
Zoom ratio (standard lens)	1.25	
Vertical keystone correction	+/- 40 degrees	
Projection methods	Front, Rear, Desktop/Ceiling (Rear, Front)	
Data compatibility	VGA, wVGA, SVGA, wSVGA, XGA, wXGA, wXGA+, SXGA, wSXGA+, UXGA, 1080P,wUXGA RB	
SDTV/ EDTV/ HDTV	480i, 480p,576i, 576p, 720p, 1080i, 1080p	
Video compatibility	NTSC, NTSC 4.43, PAL (B/G/H/I), SECAM	
H-Sync	15, 31 - 91.4 kHz	
V-Sync	24 ~ 30Hz, 47 ~ 120Hz	
Safety certification	FCC, UL, CUL, CB/CE, KC, CCC, EAC, PSB, NOM., CEC/ECO, SASO TUV-safety, UL-S(Argentina), C-Tick/RCM	
Operation temperature	5° ~ 35°C (41° ~ 95°F)	
Dimensions (W x D x H)	430.16mm x 318.00mm x 175.00mm (16.94" x 12.52" x 6.89")	
AC Input	AC Universal 100-240, Typical @ 110VAC (100-240)/± 10%	
Power consumption	Bright mode: 480W ; Normal mode: 430W ; ECO mode: 370W	
Standby	<0.5 watt (Standby) ; <3 watts (on by Lan)	
Lamp	Bright mode: 370W ; Normal mode: 330W ; ECO mode: 280W	
Audio speaker	AMP 3W speaker x 2	
Input Terminals	VGA x 2	
	DVI-D x 1	
	DISPLAYPORT x 1	
	S-Video x 1	
	5 BNC (RGBHV) x 1	
	Component x 1	
	Composite video x 1	
	HDMI x 1	
	RCA stereo x 2	
	Mini-jack stereo x 3	
Output Terminals	VGA x 1	
	Mini-jack stereo x 1	
Control Input	RS-232C	
	RJ45	
	USB Type B (for service)	
Control Output	Screen trigger: DC Jack x 1 (DC12V 200mA output function)	
	Mini-Phone Jack	
	3D Sync out	
	USB Type A (power support only)	
Security	Security cable lock slot	

Projection Distance vs. Projection Size (1080P)

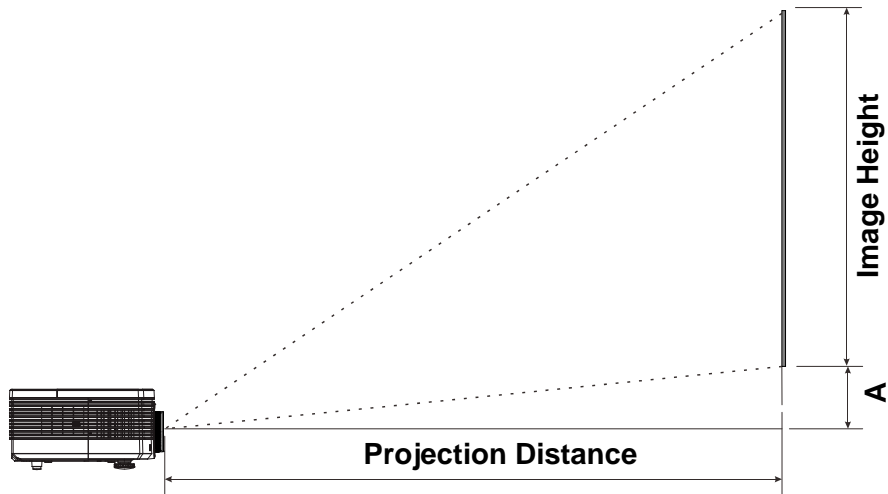

Projection Distance and Size Table

Standard projection lens: TR: 1.54– 1.93; offset=10%

IN5316HDa	TELE				WIDE			
Distance (m/inch)	1.71/ 67.3	3.42/ 134.6	4.27/ 168.2	8.55/ 336.4	1.70/ 67.1	3.41/ 134.2	6.82/ 268.4	10.23/ 402.7
Diagonal (inch/ft)	40/ 3.3	80/ 6.7	100/ 8.3	200/ 16.7	50/ /4.2	100/ /8.3	200/ 16.7	300/ 25
Image Height (mm/inch)	498/ 19.6	996/ 39.2	1245/ 49	2491/ 98.1	623/ 24.5	1245/ 49	2491/ 98.1	3736/ 147.1
Image Width (mm/inch)	886/ 34.9	1771/ 69.7	2214/ 87.2	4428/ 174.3	1107/ 43.6	2214/ 87.2	4428/ 174.3	6641/ 261.5
A (Offset - mm/inch)	50/ 2	100/ 3.9	125/ 4.9	249/ 9.8	62/ 2.5	125/ 4.9	249/ 9.8	374/ 14.7

Long throw projection lens: TR: 1.93– 2.9; offset=10%

IN5316HDa	TELE				WIDE			
Distance (m/inch)	2.57/ 101.1	6.42/ 252.8	12.84/ 505.5	19.26/ 758.3	2.14/ 84.1	6.41/ 252.3	12.82/ 504.6	19.23/ 757
Diagonal (inch/ft)	40/ 3.3	100/ 8.3	200/ 16.7	300/ 25	50/ 4.2	150/ 12.5	300/ 25	450/ 37.5
Image Height (mm/inch)	498/ 19.6	1245/ /49	2491/ 98.1	3736/ 147.1	623/ 24.5	1868/ 73.5	3736/ 147.1	5604/ 220.6
Image Width (mm/inch)	886/ 34.9	2214/ 87.2	4428/ 174.3	6641/ 261.5	1107/ /43.6	3321/ 130.7	6641/ 261.5	9962/ 392.2
A (Offset - mm/inch)	50/ 2	125/ 4.9	249/ 9.8	374/ 14.7	62/ 2.5	187/ 7.4	374/ 14.7	560/ 22.1

Short throw projection lens: TR: 0.77; offset=10%

IN5316HDa	FIX			
Distance (m/inch)	0.68/ 26.8	1.36/ 53.7	1.70/ 67.1	2.56/ 100.7
Diagonal (inch/ft)	40/ 3.3	80/ 6.7	100/ 8.3	150/ /12.5
Image Height (mm/inch)	498/ 19.6	996/ 39.2	1245/ 49	1868/ 73.5
Image Width (mm/inch)	886/ 34.9	1771/ 69.7	2214/ 87.2	3321/ 130.7
A (Offset -mm/inch)	50/ 2	100/ 3.9	125/ 4.9	187/ 7.4

Projection Distance vs. Projection Size (XGA)

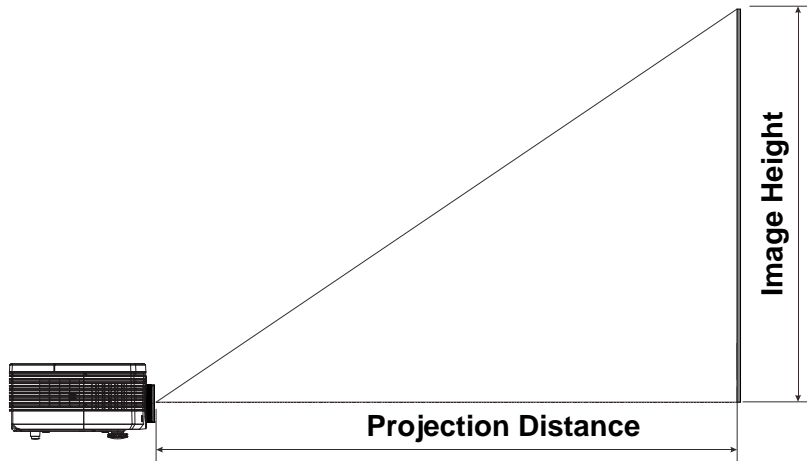

Projection Distance and Size Table

Standard projection lens: TR: 1.6~2; offset=0%

IN5312a	TELE				WIDE			
Distance (m/inch)	1.63/ 64	3.25/ 128	4.06/ 160	8.13/ 320	1.63/ 64	3.25/ 128	6.50/ 256	9.75/ 384
Diagonal (inch/ ft)	40/3.3	80/6.7	100/8.3	200/16.7	50/4.2	100/8.3	200/16.7	300/25
Keystone Correction angle (degree)	10.62	10.62	10.62	10.62	13.19	13.19	13.19	13.19
Image Height (mm/inch)	609.6/ 24	1219.2/ 48	1524.0/ 60	3048.0/ 120	762.0/ 30	1524.0/ 60	3048.0/ 120	4572.0/ 180
Image Width (mm/inch)	812.8/ 32	1625.6/ 64	2032.0/ 80	4064.0/ 160	1016.0/ 40	2032.0/ 80	4064.0/ 160	6096.0/ 240

Long throw projection lens: TR: 2~3; offset=0%

IN5312a	TELE				WIDE			
Distance (m/inch)	2.44/ 96	6.10/ 240	12.19/ 480	19.51/ 768	2.03/ 80	6.10/ 240	12.19/ 480	19.91/ 784
Diagonal (inch/ ft)	40/3.3	100/8.3	200/16.7	320/26.7	50/4.2	150/12.5	300/25	490/40.3
Keystone Correction angle (degree)	7.13	7.13	7.13	7.13	10.62	10.62	10.62	10.62
Image Height (mm/inch)	609.6/ 24	1524.0/ 60	3048.0/ 120	4876.8/ 192	762.0/ 30	2286.0/ 90	4572.0/ 180	7467.6/ 294
Image Width (mm/inch)	812.8/ 32	2032.0/ 80	4064.0/ 160	6502.4/ 256	1016.0/ 40	3048.0/ 120	6096.0/ 240	9956.8/ 392

Short throw projection lens: TR: 0.8; offset=0%

IN5312a	Fix			
Distance (m/inch)	0.65/26	1.30/51	1.63/64	2.44/96
Diagonal (inch/ ft)	40/3.3	80/6.7	100/8.3	150/12.5
Keystone Correction angle (degree)	25.11	25.11	25.11	25.11
Image Height (mm/inch)	609.6/ 24	1219.2/ 48	1524.0/ 60	2286.0/ 90
Image Width (mm/inch)	812.8/ 32	1625.6/ 64	2032.0/ 80	3048.0/ 120

Timing Mode Table

The projector can display multiple resolutions. The following table outlines the resolutions that can be displayed by the projector.

SIGNAL	RESOLUTION	H-SYNC (KHz)	V-SYNC (Hz)	COMPOSITE / S-VIDEO	VGA 1/2 /RGBHV (ANALOG)	HDMI (DIGITAL)	DP (DIGITAL)
NTSC	—	15.734	60.0	O	—	—	—
PAL/SECAM	—	15.625	50.0	O	—	—	—
VESA	720 x 400	37.9	85.0	—	O	O	O
	640 x 480	31.5	60.0	—	O	O	O
	640 x 480	37.9	72.8	—	O	O	O
	640 x 480	37.5	75.0	—	O	O	O
	640 x 480	43.3	85.0	—	O	O	O
	800 x 600	35.2	56.3	—	O	O	O
	800 x 600	37.9	60.3	—	O	O	O
	800 x 600	46.9	75.0	—	O	O	O
	800 x 600	48.1	72.2	—	O	O	O
	800 x 600	53.7	85.1	—	O	O	O
	1024 x 768	48.4	60.0	—	O	O	O
	1024 x 768	56.5	70.1	—	O	O	O
	1024 x 768	60.0	75.0	—	O	O	O
	1024 x 768	68.7	85.0	—	O	O	O
	1280 x 800	49.7	59.8	—	O	O	O
	1280 x 800	62.8	74.9	—	O	O	O
	1280 x 800	71.6	84.8	—	O	O	O
	1280 x 1024	64.0	60.0	—	O	O	O
	1280 x 1024	80.0	75.0	—	O	O	O
	1280 x 1024	91.1	85.0	—	O	O	O
	1400 x 1050	65.3	60.0	—	O	O	O
	1440 x 900	55.9	60.0	—	O	O	O
1600 x 1200	75.0	60	—	O	O	O	
1920 x 1080	67.2	60	—	O	O	O	
1920 x 1200[RB]	74.0	60	—	O	O	O	
Apple Macintosh	640 x 480	35.0	66.7	—	O	O	O
	832 x 624	49.7	74.5	—	O	O	O
	1024 x 768	60.2	74.9	—	O	O	O
	1152 x 870	68.7	75.1	—	O	O	O
SDTV	480i	15.734	60.0	—	O	O	O
	576i	15.625	50.0	—	O	O	O
EDTV	576p	31.3	50.0	—	O	O	O
	480p	31.5	60.0	—	O	O	O

SIGNAL	RESOLUTION	H-SYNC (KHz)	V-SYNC (Hz)	COMPOSITE / S-VIDEO	VGA 1/2 /RGBHV (ANALOG)	HDMI (DIGITAL)	DP (DIGITAL)
HDTV	720p	37.5	50.0	—	O	O	O
	720p	45.0	60.0	—	O	O	O
	1080i	33.8	60.0	—	O	O	O
	1080i	28.1	50.0	—	O	O	O
	1080p	27	24.0	—	O	O	O
	1080p	28.13	25.0	—	O	O	O
	1080p	33.75	30.0	—	O	O	O
	1080p	67.5	60.0	—	O	O	O
	1080p	56.3	50.0	—	O	O	O

O: Frequency supported

—: Frequency not supported

(*) VGA supports EDTV/SDTV/HDTV component with an adapter.

Projector Dimensions

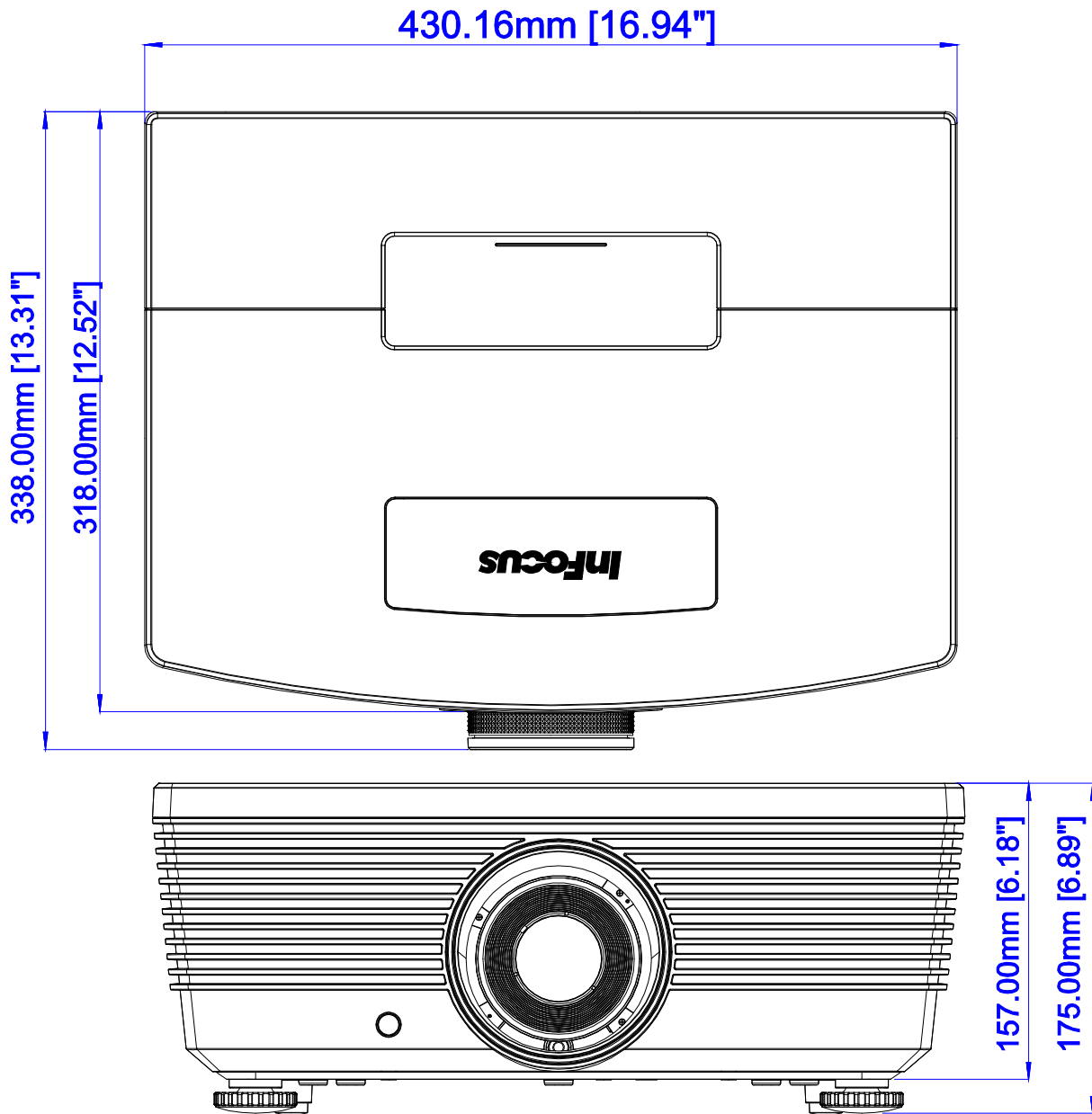

REGULATORY COMPLIANCE

FCC Warning

This equipment has been tested and found to comply with the limits for a Class B digital device pursuant to Part 15 of the FCC Rules. These limits are designed to provide reasonable protection against harmful interference when the equipment is operated in a commercial environment.

This equipment generates, uses, and can radiate radio frequency energy and, if not installed and used in accordance with the instruction manual, may cause harmful interference to radio communications. Operation of this equipment in a residential area is likely to cause harmful interference in which case the user will be required to correct the interference at his/her own expense.

Changes or modifications not expressly approved by the parties responsible for compliance could void the user's authority to operate the equipment.

Canada

This class B digital apparatus complies with Canadian ICES-003.

WEEE



NOTE: This product is covered electrical and electronic equipment under the European Union's Waste from Electrical and electronic Equipment ("WEEE") Directive (2002/96/EC). The WEEE Directive requires that covered equipment be collected and managed separately from typical household waste in all EU member states. Please follow the guidance of your local environmental authority or ask the shop where you purchased the product for collection or recycling options.

Safety Certifications

FCC, UL, CUL, CB/CE, KC, CCC, EAC, PSB, NOM., CECP/ECO, SASO TUV-safety, UL-S(Argentina), C-Tick/RCM

Serial Communication

The following table describes the serial communication configuration that should be used when interfacing to CLI via the serial port.

Windows HyperTerminal or ProComm are two tools that can be used to send CLI commands across the serial port.

Setting	Value
Bits per second	19200
Data bits	8
Parity	None
Stop bits	1
Flow control	None
Emulation	VT100

No	Function	Command	RW	Min	Max	Default	Step	Parameter
1	AC Power On (Auto power on)	APO	RW	0	1	0	1	0:Disable; 1:Enable
2	Aspect Ratio	ARZ	RW	0	5	0	1	0:Fill 1:4:3 2:16:9 3:Letterbox 4:Native 5:2.35:1
3	Auto Image	AIM	W	n/a	1	1	1	1: Enable
4	Auto Off Time No signal power off	AOT	RW	0	36	6	1	0:Never 1:5 minutes 2:10 minutes 3:15 minutes ... 35:175 minutes 36:180 minutes
5	Auto Source	ASC	RW	0	1	1	1	0:Disable; 1:Enable
6	Blank Screen	BLK	RW	0	1	0	1	0:Disable; 1 Enable
7	Brightness	BRT	RW	0	100	50	1	Display Mode=User1 only
8	Ceiling (Projection mode)	CEL	RW	0	3	0	1	0:Front 1:Rear 2:Ceiling 3:Ceiling+Rear
9	Closed Captions: Non-Muted	CLC	RW	0	1	0	1	Off On (CC1)
10	Color	CLR	RW	0	100	50	1	Video SVideo only
11	Color Temp	TMP	RW	0	2	Source Specific	1	Display Mode=User only 0:Warm 1:Normal 2:Cold
12	Contrast	CON	RW	0	100	50	1	Display Mode=User1 only

No	Function	Command	RW	Min	Max	Default	Step	Parameter
13	Current Source	SRC	RW	0	20	0	1	0 = Computer1 1 = Computer 2 3 = RGBHV 4 = HDMI1 7 = DisplayPort1 9 = Component1 11 = Composite 12 = S-Video 20 = DVI
14	Digital Zoom	DZM	RW	-10	10	0	1	Digital Zoom
15	Error Condition	ERR	R	0	9	0	1	0:No error 1:Lamp not lit after 5 Attempts 3:Lamp went out unexpectedly 4:Fan failure 5:Over-temperature 8:DMD error 9:Color wheel
16	Factory Reset	RST	W	n/a	1	1	1	1:reset
17	Freeze Screen	FRZ	RW	0	1	0	1	0:Disable; 1:Enable
18	Gamma	GTB	RW	0	5	Source Specific	1	Display Mode=User1 only 0:1.8 1:2.0 2:2.2 3:2.4 4:B&W 5:Linear
19	Horz. Position	HPS	RW	-5	5	Source Specific	1	RGB source only (HPS?) to get range
20	Vert. Position	VPS	RW	-5	5	source Specific	1	RGB source only (VPS?) to get range (VPS+) (VPS-)
21	Current Lamp Hours in Boost mode (370W)	LMO	R	0	9999	0	1	Displays the total lamp hours the current lamp has operated in Boost mode.
22	Current Lamp Hours in Normal mode (330W)	LME	R	0	9999	0	1	Displays the total lamp hours the current lamp has operated in Normal mode.
23	Current Lamp Hours in Eco mode (280W)	LML	R	0	9999	0	1	Displays the total lamp hours the current lamp has operated in Eco mode.
24	Current Lamp Hours (All modes)	LMP	R	0	9999	0	1	Displays the total lamp hours the current lamp has operated in all modes.
25	Reset Lamp Hours	LRT	W	n/a	1	1	1	Resets the lamp counter (all modes) to zero.
26	Lamp hours reset counter	LMR	R	0	9999	0	1	Displays the number of times the lamp counter has been reset

No	Function	Command	RW	Min	Max	Default	Step	Parameter
27	Total Projection Hours (lamp1+lamp2+...)	LMT	R	0	9999	0	1	Displays the total number of hours the projector has been in operation (all lamps).
28	Lamp Life	LIF	R	n/a	1500	1500	n/a	Lamp life 1500
29	Lamp Power Select High power (Boost) / Low power (Normal) / Eco power (Eco)	IPM	RW	0	2	1	1	This Read/Write command sets the lamp mode 0 = Eco 1 = Normal 2 = Boost
33	Language	LAN	RW	0	26	0	1	0:English 1:French 2:German 3:Spanish 4:Portuguese 5:Simplified Chinese 6:Traditional Chinese 7:Italian 8:Norwegian 9:Swedish 10:Dutch 11:Russian 12:Polish 13:Finnish 14:Greek 15:Korean 16:Hungarian 17:Czech 18:Arabic 19:Turkish 20:Vietnamese 21:Japanese 22:Thai 23:Farsi 24:Hebrew 25:Bahasa 26:Danish
34	Menu	MNU	RW	0	1	0	1	0:Clear; 1:Display
35	Menu Navigation	NAV	W	0	5	n/a	1	0:Menu Key 1:Up Key 2:Down Key 3:Select Key 4:Left Key 5:Right Key
36	Menu Transparency	TOE	RW	0	4	0	5	0:0% 1:25% 2:50% 3:75% 4:100%
37	Mute	MTE	RW	0	1	0	1	0:Disable; 1:Enable
38	Overscan	OVS	RW	0	1	0	1	0:Disable; 1:Enable
39	Phase(Frequency)	MSS	RW	0	31	source Specific	1	RGB source only
40	Power	PWR	RW	0	1	0	1	0:Turn Off 1:Turn On

No	Function	Command	RW	Min	Max	Default	Step	Parameter
41	Presets	PST	RW	0	8	source Specific	1	Display mode 0:Presentation 1:Bright 2:Game 3:Movie 4:TV 5:sRGB 6:Blackboard 7:User1 8:User2
42	Projector Firmware Ver.	FVS	R	string				LX737-692IF-DPEXX
43	Projector Info menu	PRI	W		1		1	1:Display Status Menu
44	Projector Model	MDL	R	string				XGA: IN5312a 1080P: IN5316HDa
45	Projector Resolution	NRS	R	string				XGA
46	Search Screen	DSU	RW	0	4	0	1	0:Blue 1:Black 2:White 3:Red 4:Green
47	Sharpness	SHP	RW	0	31	16	1	Display mode User 1 only same as OSD range
48	System State	SYS	R	0	18	0	1	0:Standby 2:Start Up 12:Cooling 18:Error
49	Tint	TNT	RW	0	100	50	1	Tint
50	Tracking	MTS	RW	-5	5	0	1	RGB source only
51	Vert. Keystone	DKV	RW	-40	40	0	1	Vertical keystone
52	Volume	VOL	RW	0	10	5	1	Volume