



WAM-432

TRUE DIVERSITY DIGITAL WIRELESS AUTOMATIC MIXER

Installation and Operation

 100% recycled paper
100% papier recyclé

Contents

01 Safety Operation and Notice	P3
02 System Performance Feature	P4
03 Mixer Installation Method	P6
04 Packing List	P7
05 Front Panel Function Introduction	P8
06 Rear Panel Function Introduction	P9
07 Transmitter Function Introduction	P10
Handheld microphone (UH-222)	P10
Bodypack transmitter (UT-222)	P12
Boundary microphone (UB-222)	P14
Desktop gooseneck microphone (UD-222)	P15
08 System Setup and Operation	P17
LCD display introductions	P17
System Main Menu Settings	P18
Channel Menu Settings	P24
09 Mixer Equipment Installation	P26
10 Transmitter Battery Installation	P27
11 User-friendly steps	P29
12 System Applications Connection Diagram	P33
13 Technical Specification	P34

Thank you for choosing a RELACART professional wireless automatic mixer system. You have joined thousands of other satisfied customers. Our years of professional experience of design and manufacturing to ensure our products' quality, performance and reliability.

01 Safety Operation and Notice

1. Please read instructions for safety operation carefully before installation and operation. Please save your safety operation guide for future reference.
2. Do not scratch, bend, twist, stretch or heat the power cord as this may cause damage to the power cord, resulting in a fire or electric shock.
3. Do not open the device shell, otherwise it may cause electric shock. If you need to repair, maintain or repair, please contact your local agent.
4. Do not touch the power plug with wet hands as this may cause a fire or electric shock.
5. Do not attempt to modify this device. Failure to do so may result in personal injury or product malfunction.
6. Do not use this equipment near water.
7. If the power cord is damaged (such as a broken wire or bare core), obtain replacement parts from your dealer. Continued use of the equipment with a damaged power cord may result in fire or electric shock.
8. To move the device he power, unplug the power cord, and unplug all connecting cables as this may damage the cable, resulting in a fire or electric shock.
9. Before cleaning the device, unplug the power cord and unplug all connecting cables. Please clean it with a dry soft cloth.
10. If the device is not in use for a long time, turn off the power, it is best to unplug the socket.
11. With the power plug and appliance coupler as the disconnecting device, it should be kept easy to operate.
12. For the safe use of the equipment and adequate ventilation, the minimum clearance around the equipment should be maintained at a distance of 5 cm or more.
13. DO NOT cover the Ventilation holes, such as: newspaper / fabric / curtains and other items.
14. Equipment should not be placed on a bare flame source, such as: lit candles.
15. Battery should not be exposed to sunshine, roasted or other high temperature overheating environment.
16. Do not throw the waste battery, please put in the designated bins.
17. Water protection rating: IPX0
18. The device can be used normally in tropical / temperate climates.
19. This product is only suitable for safe use at the altitude of 2000m and below.
20. This symbol "⚡" indicates that dangerous voltage constituting a risk of electric shock is present within this unit.
21. All Relacart products will be afforded one year free maintenance except for man-made damage, such as:
 - the device is damaged by man-made factors.
 - the device is damaged by improper operation.
 - some components are damaged or loss after the self-disassembly.

02 System Performance Feature

WAM-432 automatic intelligent wireless mixer is a new generation of products designed with high-performance microcomputer processor as the core of Relacart's strong research and development strength. The design is professional and novel, and the digital control technology and advanced audio processing technology. The perfect combination of processing technology and network technology, intelligent control, fully automatic work; connecting AMC-20 audio and video control system can realize audio and video management functions. Apply to high-demand multi-purpose demonstration halls, small and medium-sized performances, hotels, boardroom, government departments, courts, etc.

Key Features:

- International EIA STANDARD 1U metal chassis, combined with new-style compact and elegance LCD display.
- Bright and easy-to-read LCD display shows RF/AF, level and other operation status.
- Super wide frequency range UHF 521.25MHz~936.85MHz, AFS "automatic frequency selection", CPU intelligent antenna diversity receiving.
- Press [IR] button to upload automatically the receiver frequency to the transmitter.
- The built-in high-performance DSP processor, can processing system gains and environment noise automatically and avoid howling effectively.

03 Mixer Installation Method

- Noise Adaptive Threshold manages the audio system by distinguishing dynamic audio (such as speech) and the noise floor (such as air conditioning). It continuously adjusts the activation threshold, so that only speech level louder than the background noise can open a channel.
- Cascaded connection function, can daisy chain up to 8 pieces of WAM-432, 32 microphone delegate can be used at the same time.
- RS-232 interface for external auto video tracking system VTS-2000 or intelligent central control system.
- Select the simultaneous open microphones to 1 unit, 2 units, 3 units or 4 units.
- Last microphone on selectable for continuous room ambiance. Microphone holds time for 0.1s to 1s. With priority microphone function.
- The automatic mixer offers a balanced XLR output for the audio connection. RJ11 and DIN terminals are provided for linking 2 units.
- Contrary to wired systems, no cables have to be laid or holes drilled. The system, can easily be integrated into rooms and without damaging any materials.
- The new optimized circuit design, good sound quality, transmission distance is longer and more stable.
- Precise low-power circuit design, use two AA alkaline battery, battery life is one time longer as common.
- Cooperates with RELACART wireless handheld microphone UH-222, wireless bodypack transmitter UT-222, wireless desktop microphone UD-222 or wireless boundary microphone UB-222.
- The WAM-432 wireless automatic mixer is ideal for meetings, seminars, teleconferencing, house of worship services, broadcast and conference applications.

Installation:

- ① For better operation the receiver should be at least 3ft (1m). above the ground and at least 3ft (1m). away from a wall or metal surface to minimize reflections.
- ② Attached a pair of UHF antennas to the antenna input jacks, the antenna are normally positioned in the shape of a " V " (both 45° from vertical) for best reception.
- ③ Keep antennas away from noise sources such as computer, digital equipment, motors, automobiles and neon lights, as well as away from large metal objects
- ④ Keep open space between the receiver and transmitter for better reception.
- ⑤ The transmitter should be at least 6ft (2m). from the receiver .

04 Packing List

- ◆ Wireless automatic mixer *1
- ◆ Wireless transmitter *4
- ◆ BNC Antenna *2
- ◆ External power adapter * 1
- ◆ Installation and operation * 1
- ◆ 1 meter audio cable *1
- ◆ 60cm coaxial-cable * 2
- ◆ RJ-11 Telephone wire * 1
- ◆ 1.5V AA battery *8

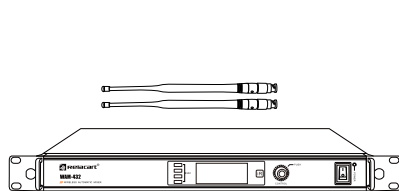

External power adapter



Audio cable



Coaxial cable



RJ-11 Telephone wire



Installation
and
Operation

05 Front Panel Function Introduction

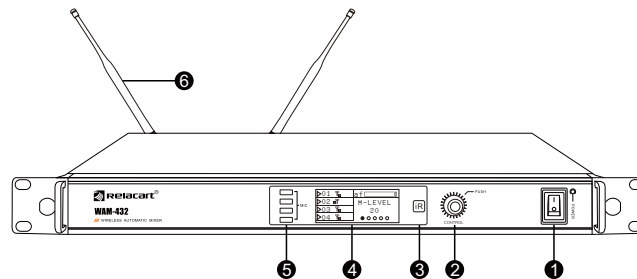

- ❶ Ship-type power switch: Dial up ("I" symbol) turn on the power switch, dial down ("O" symbol) turn off the power.
- ❷ Function knob (encoder): Select menu clockwise/counterclockwise, press to set system operation menu, long press to enter main menu.
- ❸ Infrared data transfer window (IR) : Transmit system data from the receiver to the transmitter, so that CH1 to CH4 are in the same frequency, in order to realize the synchronization.
- ❹ LCD display: Display working channel, control setting status and operation menu.
- ❺ Channel buttons: Press CH1/ CH2/ CH3/ CH4 button, in conjunction with the (CONTROL) knob, to step through menus, select operating frequency and infrared data transfer.
- ❻ 1/2 wavelength BNC antenna: Used to receive radio transmitter for transmission.

06 Rear Panel Function Introduction

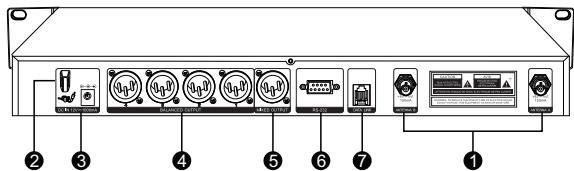

- 1 RF antenna diversity BNC input connector: Suitable for connection of antenna A and antenna B, and supports DC 8V/150mA power output.
- 2 Anti-pull device: used to fix the connecting cable of the external power adapter.
- 3 DC IN socket: connect to external power adapter.
- 4 Single channel balanced audio output port (BALANCED OUT): Each channel outputs audio separately.
- 5 Balanced audio output port (MIXER OUT): The XLR port can be used to connect a standard 2 conductor shielded cable the receiver output to a balanced microphone level input on a mixer.
- 6 RS-232 interface: Connect automatic video tracking system VTS-2000 or the control system.
- 7 Serial data link port (DATA LINK): When multiple WAM-432 receivers are working, RELACART provide dedicated data cable, multiple machines can exchange data.

07 Transmitter Function Introduction

Handheld microphone (UH-222)

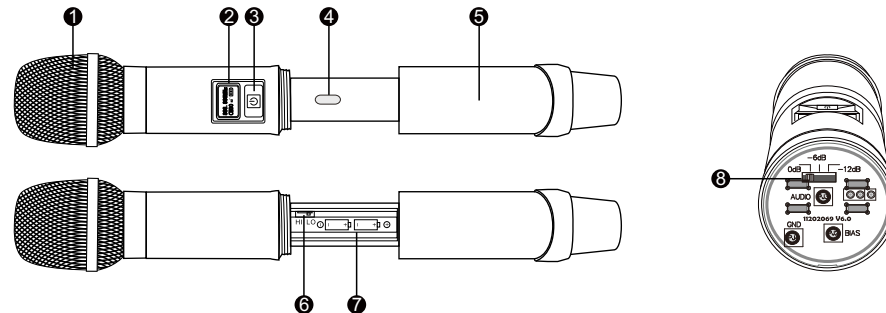

- 1 Microphone Head: It is the important part to transfer sound into audio signal. The microphone head is separate to change other microphone head if needed.
- 2 OLED display: display the frequency, channel, lock and battery life. Battery indicator displays a maximum of 4 bar segments. When it leaves 1 bar segment, the batteries should be replaced immediately.
- 3 Power Button/Mute Button: Press the power button to turn on the transmitter, press the power button 1.5 second enter the mute status, press one more time to close the mute function. Long press 3 seconds to turn off the transmitter.

- ④ Infrared data receiving window (IR): Synchronization of transmitters via IR interface from receiver.
- ⑤ Battery Cover: Unscrew it can reveal the battery compartment; When installing, replacing or setting the infrared frequency, the battery cover must be opened.
- ⑥ RF power switch: HI is 50 mW, LO is 30 mW.
- ⑦ Battery Compartment: Insert 2 fresh 1.5V AA batteries. (Alkaline type is recommended. Please remember to replace both batteries.)
Warn: Observe correct polarity as marked inside the battery compartment to avoid damage to the internal electric parts.
- ⑧ The audio gain switch: 3 optional (0dB, -6dB, -12dB), the factory default setting is 0dB (no attenuation); when the volume is too large, can according to the actual situation adjusted the gain (-6dB or -12dB).

Bodypack transmitter (UT-222)

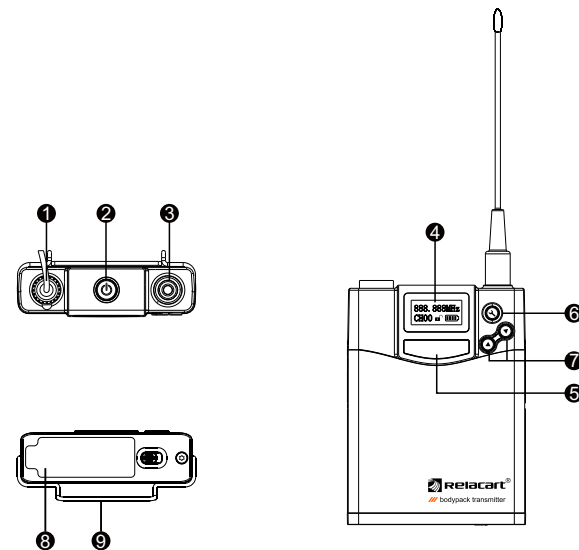

- ❶ 3.5mm crimp type antenna: For transmitting a bodypack radio carrier.
- ❷ Power Button/Mute Button: Press the power button to turn on the transmitter, press the power button 1.5 second enter the mute status, press one more time to close the mute function. Long press 3 seconds to turn off the transmitter.
- ❸ TA4M/LEMO input jack: Connect to a microphone or instrument cable.
- ❹ OLED display: display the frequency, channel, lock and battery life. Battery indicator displays a maximum of 4 bar segments. When it leaves 1 bar segment, the batteries should be replaced immediately.
- ❺ Infrared data receiving window (IR): Synchronization of transmitters via IR interface from receiver.
- ❻ “⏏” button: Press to enter the selection or confirmation menu.
- ❼ “⏏/⏏” allow control button: Press the allow button to edit the menu parameter values.
- ❽ Battery Compartment: Pull to open the battery door and insert 2 fresh 1.5V AA batteries. (Alkaline type is recommended. Please remember to replace both batteries.)
Warn: Observe correct polarity as marked inside the battery compartment to avoid damage to the internal electric parts.
- ❾ Belt clip: Fix the transmitter around the user’s waist.

Boundary microphone (UB-222)

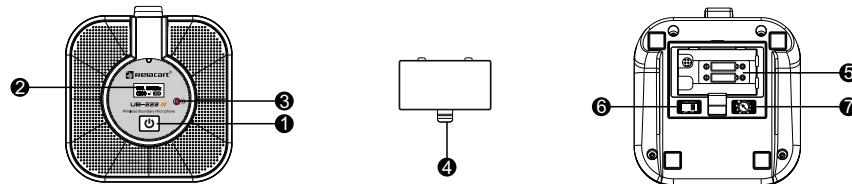

- ❶ Power Button/Mute Button: Press the power button to turn on the transmitter, press the power button 1.5 second enter the mute status, press one more time to close the mute function. Long press 3 seconds to turn off the transmitter.
- ❷ LCD display: Display the frequency, channel, lock and battery life. Battery indicator displays a maximum of 4 bar segments. When it leaves 1 bar segment, the batteries should be replaced immediately.
- ❸ Infrared data receiving window (IR): Synchronization of transmitters via IR interface from receiver.
- ❹ Battery door switch: Open the battery door by sliding the switch.
- ❺ Battery compartment: Insert 2 fresh 1.5V AA batteries. (Alkaline type is recommended. Please remember to replace both batteries.)
Warn: Observe correct polarity as marked inside the battery compartment to avoid damage to the internal electric parts.
- ❻ Low cut switch: cut off the low-frequency signal below 150Hz.
- ❼ Gain knob: adjust the input signal size.

Gooseneck conference microphone (UD-222)

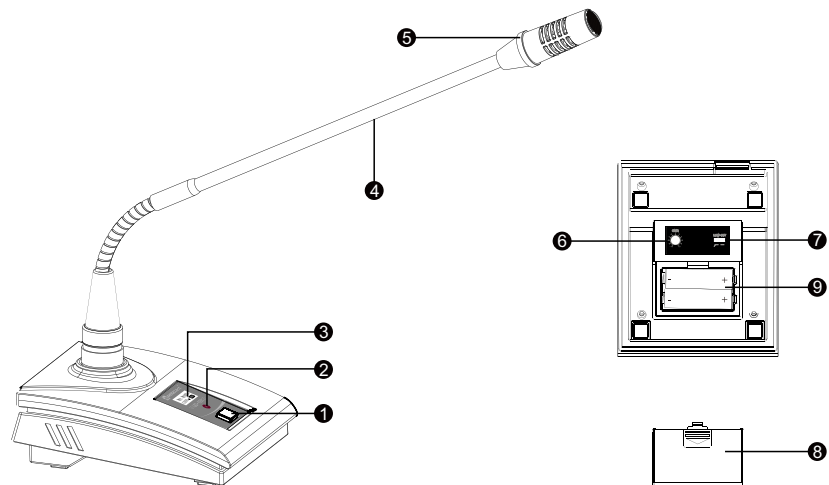

- 1** Power Button/Mute Button: Press the power button to turn on the transmitter, press the power button 1.5 second enter the mute status, press one more time to close the mute function. Long press 3 seconds to turn off the transmitter.
- 2** Infrared data receiving window (IR): Synchronization of transmitters via IR interface from receiver.
- 3** LCD display: Display the frequency, channel, look and battery life. Battery indicator displays a maximum of 4 bar segments. When it leaves 1 bar segment, the batteries should be replaced immediately.
- 4** Microphone rod: bending gooseneck design, can flexibly put the pickup head to any position.
- 5** Speaking Aperture: When you open the microphone to speak, this instruction light bright.
- 6** Gain knob: adjust the input signal size.
- 7** Low cut switch: cut off the low-frequency signal below 150Hz.
- 8** Battery door switch: Open the battery door by sliding the switch.
- 9** Battery compartment: Insert 2 fresh 1.5V AA batteries. (Alkaline type is recommended. Please remember to replace both batteries.)
Warn: Observe correct polarity as marked inside the battery compartment to avoid damage to the internal electric parts.

08 System Setup and Operation

LCD display introductions

Main display:

- 1 Triangle symbol-when the triangle symbol is on, the microphone is turned on(speaking/allowed to speak). When the last lock function is opened, or when the microphone is set to priority to the channel, the triangle symbol of the corresponding channel is also on.
- 2 Channel Display: Channel on use.
- 3 RF Signal: Show the strength of receiving signal.
- 4 Main Volume: Show the volume output.
- 5 Working Status: Display the operating status.
- 6 Scroll Bar Display.

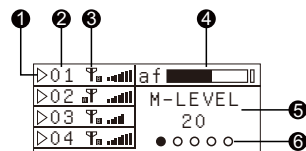

Channel display:

- 1 Channel number display: Show the operating channel (RX1 means receiving channel 1)
- 2 RF signal
- 3 AF signal
- 4 Group and Channel display
- 5 Frequency display
- 6 Transmitter battery status
- 7 SQUELCH status
- 8 Audio output status

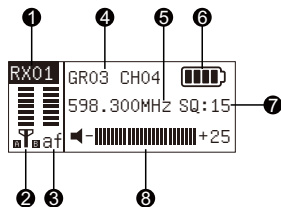

System Main Menu Settings

Keep the "CONTROL" knob pressed for approx. 3 seconds to enter the setting menu. Turn the "CONTROL" knob to browse the menu items and press the knob to select the desired function. Turn the knob to make your settings and press the knob to confirm them. Any settings changed will be instantly accepted by the unit and transferred from a master device to a secondary device. Select "EXIT" to exit the setting mode. The standard display will be indicated. If no button has been pressed for a few seconds, the setting mode will be exited automatically.

1. Turn on the wireless mixer, the LCD displays the preset data.

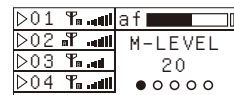

2. Rotate the "CONTROL" knob to view the setting status.

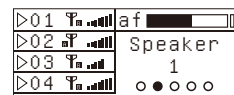

3. To enter the main menu mode: Press and hold the “CONTROL” knob 3 seconds to enter the edit mode. rotate this knob once to select and set mode: Output Level, Speaker, Priority, Threshold, Pilot, Brightness, Language, Keyboard Lock, Reset or Exit.

(1) Output Level: Can adjust the volume level at the XLR output. Select “Output Level”, then press CONTROL knob to enter edit mode, rotate this knob, LCD will display 1dBm step, providing a 0dBm to 25dBm ranges. Press CONTROL knob to confirm the desire choice, then LCD move to the next setting.



(2) Speaker: Set the number of open microphones. Select “Speaker”, then press CONTROL knob to enter edit mode, rotate this knob, to select one of the three open microphone number modes: “ 1 ”, “ 2 ”, and “OPEN ”. If the maximum number of microphones is switched on, it will not be possible to activate another microphone. This limitation will not apply to a microphone with priority. Press CONTROL knob to confirm the desire choice, then LCD move to the next setting.



(3) Priority: Set the microphone at priority. Select “Priority”, then press CONTROL knob to enter edit mode, rotate this knob, to choose the priority channel, if there are two receivers to link together for use. the LCD will display the first one A. the second one B. can set two channels at priority at the most. press CONTROL knob to confirm the desire choice. Finally contrarotate CONTROL knob. until the arrowhead on the lower right corner becomes dotted line. press CONTROL. LCD move to the next setting.

(Note: In the priority selection, all the channels are displayed: 01, 02, 03, 04, corresponding front panel respectively: CH1, CH2, CH3, Ch4.)

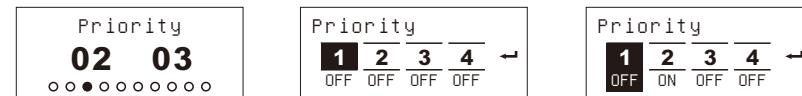

(4) Threshold: According to the ambient noise to set the threshold manually. Select “Threshold”, then press CONTROL knob to enter edit mode, rotate this knob, LCD will display 1dBm step, providing a 1dBm to 10dBm ranges. Press CONTROL knob to confirm the desire choice, then LCD move to the next setting.



- (5) Pilot: Activates/deactivates the pilot tone evaluation. Select "Pilot", then press CONTROL knob to enter edit mode, rotate this knob, the LCD will display "ON" or "OFF", if stopping on "ON", the mixer detects and evaluates the pilot tone. The pilot tone supports the mixer's squelch function and prevents interference due to RF signals from other devices; if stopping on "OFF", the microphone will turn off the pilot tone evaluation. Press CONTROL knob to confirm the desire choice, then LCD move to the next setting.

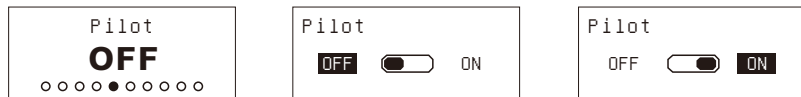

- (6) Brightness: Adjusts the display brightness in 10 steps. Select "Brightness", then press CONTROL knob to enter edit mode, rotate this knob, to set the screen display contrast, LCD will display 01 step, providing a 01 to 10 ranges, the default factory settings of the display contrast is 5. Press CONTROL knob to confirm the desire choice, then LCD move to the next setting.

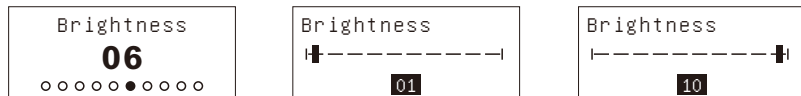

- (7) Language: Changes the menu language. Select "Language", then press CONTROL knob to enter edit mode, rotate this knob, to select "Chinese" or "English". English is the default display language after boot. In this menu item you can switch to Chinese. Press CONTROL knob to confirm the desire choice, then LCD move to the next setting.

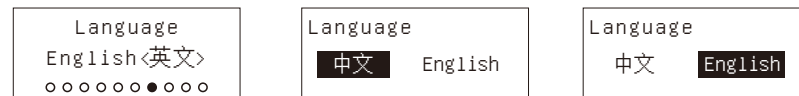

- (8) Keyboard Lock: Activates/deactivates the lock mode. Select "Keyboard Lock", then press CONTROL knob to enter edit mode, rotate this knob, the LCD will display "ON" or "OFF", if stopping on "ON", the lock mode is activated, it is not possible to change menu settings; if stopping on "OFF", the lock is released, using any of the buttons to operate and control. Press CONTROL knob to confirm the desire choice, then LCD move to the next setting.



- (9) Reset: Reset to default settings. Select "Reset", then press CONTROL knob to enter edit mode, rotate this knob, the LCD will display "Yes" or "No", if stopping on "Yes", This menu item resets the mixer to its default settings; if stopping on "No", return to the menu. Press CONTROL knob to confirm the desire choice, then LCD move to the next setting.

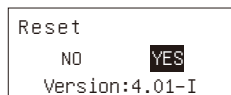
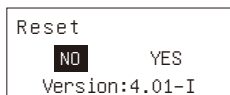
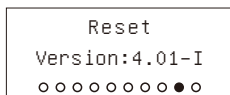

- (10) Exit: Select "Exit", then press CONTROL knob to exit the system main menu and return to the main interface.

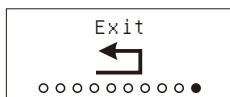

Channel Menu Settings

Shortly press a channel button CH1 to CH4 to enter the corresponding channel menu. Turn the CONTROL knob to browse the menu items and press the knob to select the desired function. Turn the knob to make your settings and press the knob to confirm them. It is necessary to synchronize the corresponding microphone for the changes made to take effect.

* Same operation as RX1 to set Rx2, RX3 and RX4.

- (1) Frequency: Stop at "Group", then press "CONTROL" knob to select the preset 10 group manually; Stop at "Channel", then press "CONTROL" knob to select the preset 14 channels manually.

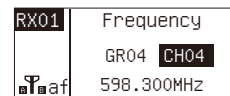
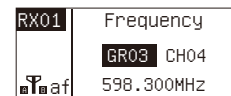
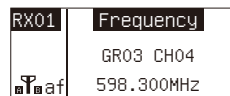

- (2) AFS: Stop at "AFS", then press "CONTROL" knob, system will auto-scan and lock on to an open, interference-free frequency in 40s. The indication >>>>> will pulsate during the scan.



09 Mixer Equipment Installation

- (3) Sync: Infrared data transmitting. Let the transmitter's IR window face to "SYNC" window, press "CONTROL" to receive the data signal from the receiver. The indication >>>>> will pulsate during IR transmission.



- (4) SQELCH: Stop at "SQELCH", then press "CONTROL" knob, the squelch level is adjustable in the 05dB steps, providing a 05dB to 35dB range. Press "CONTROL" confirm the desired choice. (If interference is a problem, first consider trying a different frequency, either manually or scanning.)



- (5) Exit: Stop at "Exit", then press "CONTROL" knob to exit the single channel menu setting and return to the channel interface.

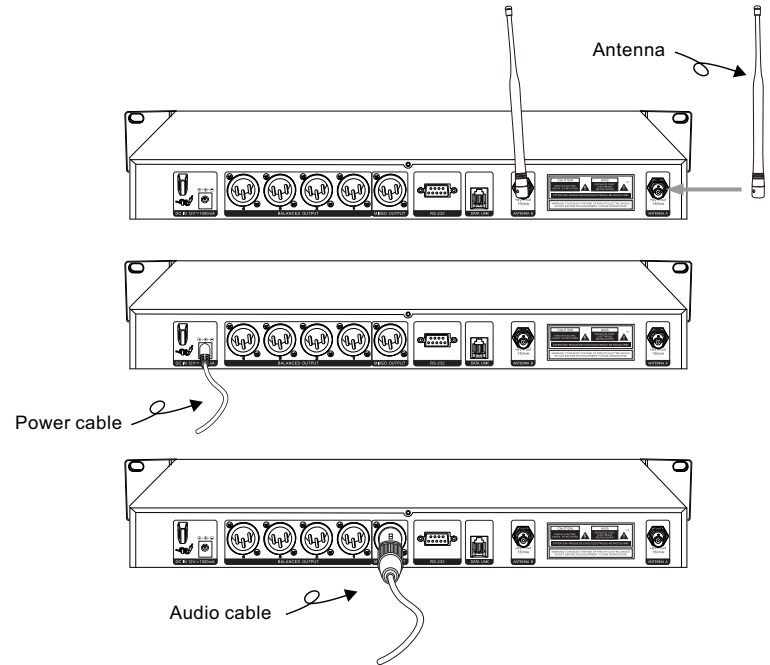

10 Transmitter Battery Installation

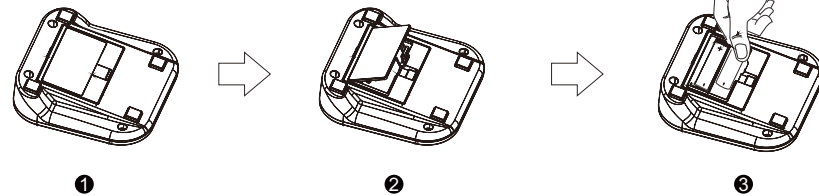
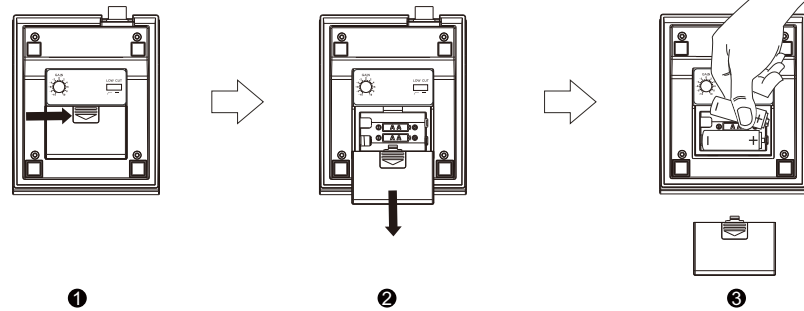
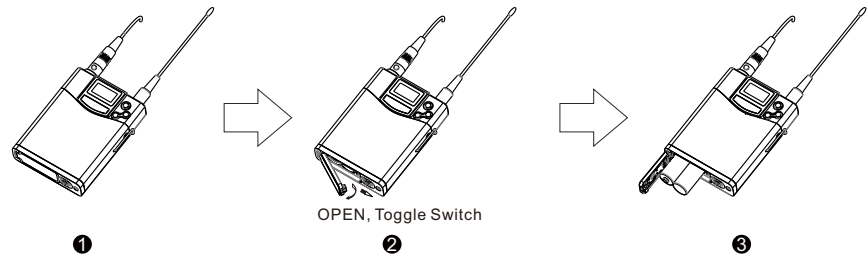
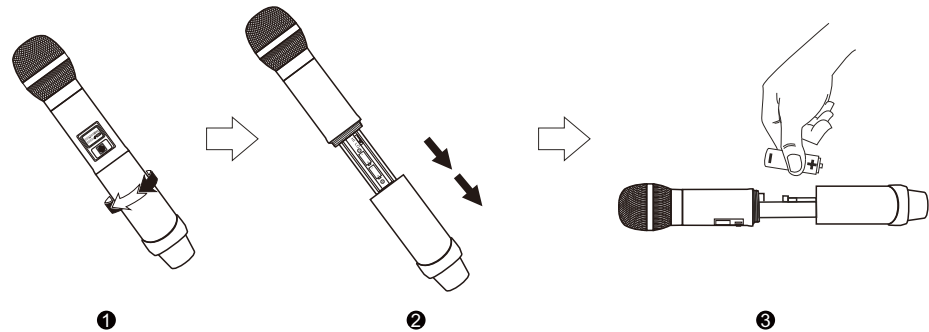

11 User-friendly steps

1. After connecting the antenna and the power adapter, turn on the receiver by pressing the power button ("I" symbol), the display and power indicator are all on. (As shown below)

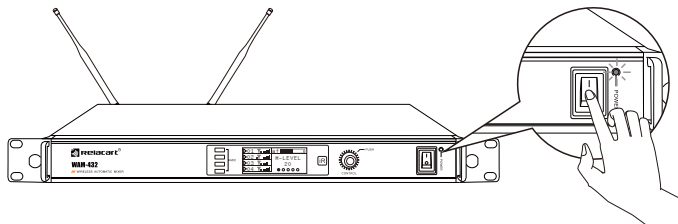

2. Long press and hold the mixer "CONTROL" encoder to enter the main menu setting of the system.

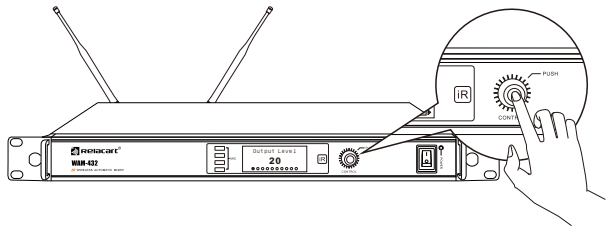

3. Press the corresponding channel button, turn the "CONTROL" encoder clockwise or counterclockwise to scroll the setting menu, and short press the "CONTROL" encoder to enter the menu for setting or confirmation. (As shown below)

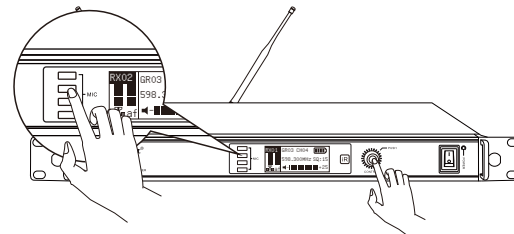

- a. If there is any interference with the channel, turn the encoder clockwise to "AFS" interface. (If there is no interference, skip directly "AFS" operation, to "SYNC" on the use of frequency)

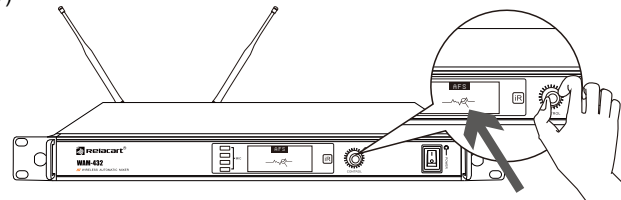

b. Press the encoder into the automatic search interface, as shown:

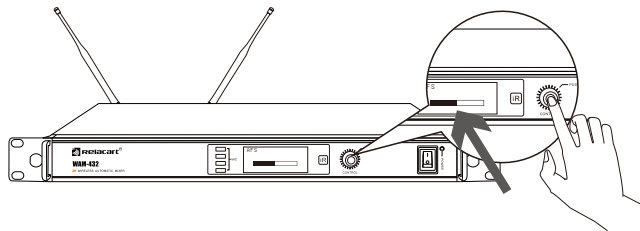

c. The searched channel will automatically calculate the clean and undisturbed frequency. The RF display on the receiver's display will be 0, if not, repeat this action until a clean frequency is found.

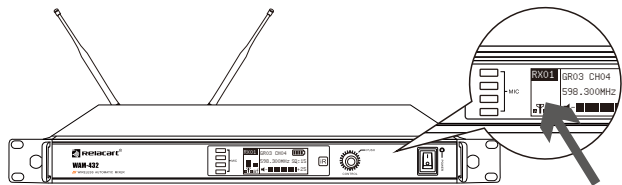

4. Automatic search to a clean frequency, counterclockwise rotation of the encoder to the "SYNC" interface.

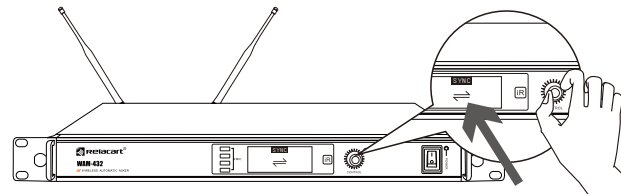

Align the transmitter infrared frequency window with the receiver IR infrared frequency window, press the encoder to determine the frequency, When the RF signal is on, the microphone of the corresponding channel can be used to speak. When the microphone speaks, the receiver AF signal hops move, said that can be used normally, other channels the same operation. As shown:

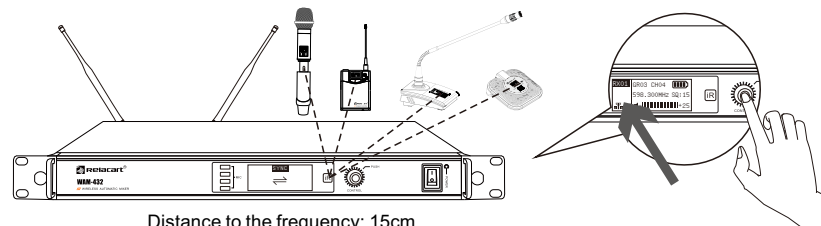

Distance to the frequency: 15cm

12 System Applications Connection Diagram

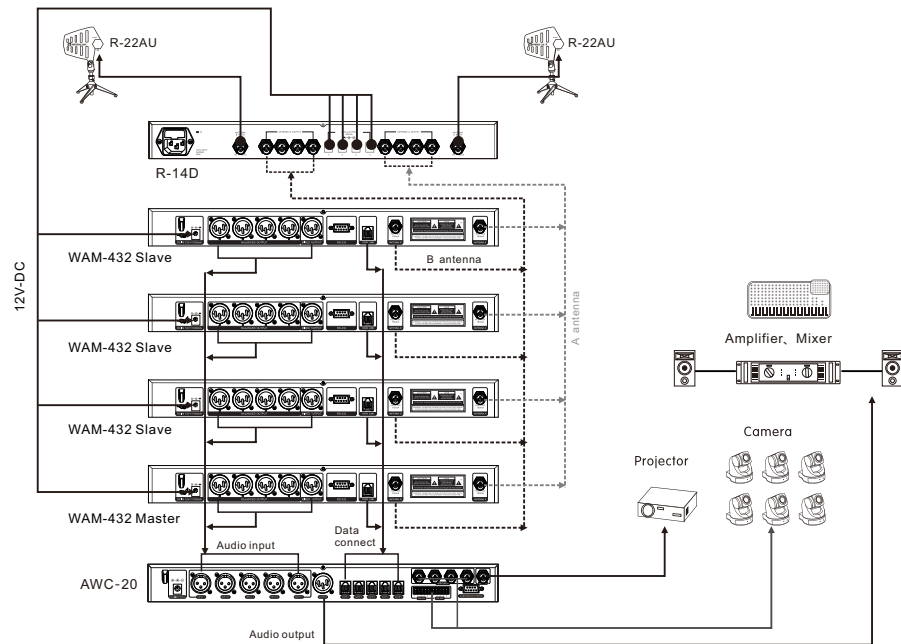

13 Technical Specification

WAM-432 Wireless Automatic Mixer

Main Frame Size:	EIA standard 1U
Frequency Stability:	$\pm 0.005\%$ ($-10^{\circ}\text{C} \sim 50^{\circ}\text{C}$)
Carrier Frequency Range:	521.25MHz ~ 936.85MHz
Modulation Mode:	FM
Sensitivity:	5dBu, S/N >60dB at 25 deviation
Bandwidth:	32MHz
Max Deviation Range:	$\pm 45\text{KHz}$
Frequency response:	65Hz-16KHz, 150Hz-16KHz (low cut)
Harmonic Distortion:	$\leq 0.7\%$ @1KHz
Dynamic range:	> 95dB
S/N:	>92dB
Audio Output:	XLR socket
Data Connection:	RJ11
Communication Port:	RS-232
Power Supply:	DC 12V/1A
Operating Current:	700mA
Dimension (mm):	410 (W) x 26 (D) x 43 (H)
Weight:	Approximately 2.5 kg

UH-222 Handheld Microphone

Carrier Frequency Range:	521.25MHz ~ 936.85MHz
Oscillation:	PLL Synthesized
Harmonic Radiation:	<45dBm
Bandwidth:	134MHz (It depends on the region)
Max. Deviation Range:	±45KHz
Microphone Element:	Dynamic/Condenser (removable)
RF Output Power:	10MW/40MW
Battery:	AA x 2
Current Consumption:	110mA (Typical)
Battery Current/Life:	Approximately 11 hours
Microphone Lengths (mm):	52 (Φ) x 255 (L)
Weight:	Approximately 235g (w/o battery)

UT-222 Bodypack Transmitter

Carrier Frequency Range:	521.25MHz ~ 936.85MHz
Oscillation:	PLL Synthesized
Harmonic Radiation:	<45dBm
Bandwidth:	134MHz (It depends on the region)
Max. Deviation Range:	±45KHz
Input Connector:	4-pin mini-XLR connector
RF Output Power:	10MW/40MW
Battery:	AA x 2
Current Consumption:	110mA (Typical)
Battery Current/Life:	Approximately 11 hours
Dimension (mm):	84 (H) x 66 (W) x 23 (D)
Weight:	Approximately 155g (w/o battery)

UB-222 Boundary Microphone

Carrier Frequency Range:	521.25MHz ~ 936.85MHz
Modulation:	FM
Harmonic Radiation:	<45dBm
Bandwidth:	134MHz (It depends on the region)
Max. Deviation Range:	±45KHz
Elements:	Fixed-charge back plate,
Polar Pattern:	Cardioid (120° sound-pickup angle)
RF Output Power:	10mW
Dynamic Range:	>95dB, A Weighting
Audio Potentiometer:	-10 ~ 10dB
Frequency Response:	50Hz — 17KHz
Low-cut Switch:	200Hz/-6dB
Battery:	AA x 2
Current Consumption:	130mA(Typical)
Battery Current/Life:	Approximately 9 hours
Dimension (mm):	110 (W) x 40 (H) x 110 (D)
Weight:	Approximately 505g

UD-222 Desktop Gooseneck Microphone

Carrier Frequency Range:	521.25MHz ~ 936.85MHz
Oscillation:	PLL Synthesized
Harmonic Radiation:	<50dBm
Bandwidth:	134MHz (It depends on the region)
Max. Deviation Range:	±45KHz
RF Output Power:	10MW
Gain Adjustment Range:	-10dB ~ +10dB
Low cut switch:	>200Hz
Battery:	AA x 2
Current Consumption:	130mA (Typical)
Battery Current/Life:	Approximately 9 hours
Microphone Lengths (mm):	340, 420 (default), 480
Weight:	Approximately 830g (w/o battery)