

# Titan™

## OPERATING MANUAL AND USER GUIDE

Titan™ 8 Passive

Titan™ I2 Passive

Titan™ I5 Passive

Titan™ 8 Active MKII

Titan™ I2D

Titan™ I5D

Titan™ Sub A12

Titan™ Sub I5A MKII



[www.wharfedalepro.com](http://www.wharfedalepro.com)

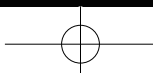



## IMPORTANT WARNINGS & SAFETY INSTRUCTIONS

1. Read these instructions
2. Follow all instructions
3. Keep these instructions
4. Heed all warnings
5. Do not use this apparatus near water
6. Clean only with dry cloth.
7. Do not block any ventilation openings. Install in accordance with the manufacturer's instructions.
8. Do not install near any heat sources such as radiators, heat registers, stoves, or other apparatus (including amplifiers) that produce heat.
9. Do not defeat the safety purpose of the polarised or grounding plug. A polarised plug has two blades with one wider than the other. A grounding plug has two blades and a third grounding prong. The wide blade or the third prong is provided for your safety. If the provided plug does not fit into your outlet, consult an electrician for replacement of the obsolete outlet.
10. Protect the power cord from being walked on or pinched particularly at the plugs, convenience receptacles, and at the point where they exit from the apparatus.
11. Only use attachments/accessories specified by the manufacturer.
12. Use only with a cart, stand, tripod, bracket, or table specified by the manufacturer, or sold with the apparatus. When a cart or rack is used, use caution when moving the cart and apparatus combination to avoid injury from tip-over.

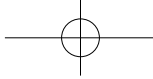

13. Unplug the apparatus during lightning storms or when unused for long periods of time.
14. Refer all servicing to qualified personnel. Servicing is required when the apparatus has been damaged in any way including but not limited to power supply cord or plug damage, liquid ingress, foreign objects in the chassis, exposure to rain/moisture or impact damage. In addition the unit must be serviced when you experience any abnormal operation.
15. CAUTION: These servicing instructions are for use by qualified service personnel only. To reduce the risk of electric shock, do not attempt to perform any servicing other than that contained in the operating instructions unless you are qualified to do so. In addition opening the casing will result in your warranty becoming null and void.
16. Do not install this apparatus in a confined space such as a book case or similar unit. Good ventilation should be maintained around the apparatus and any vents, air-inlets or fans should not be obstructed by objects such as paper, table-cloths, curtains etc.
17. WARNING: To reduce the risk of fire or electric shock, do not expose the apparatus to rain or moisture. The apparatus should not be exposed to dripping or splashing and objects filled with liquids, such as vases, should not be placed on the apparatus.
18. WARNING: The mains plug/appliance coupler is used as a disconnect device, the disconnect device shall remain readily operable.



19. - This lightning flash with arrowhead symbol within an equilateral triangle is intended to alert the user to the presence of non-insulated "dangerous voltage" within the product's enclosure that may be of sufficient magnitude to constitute a risk of electric shock.
  - Warning: To reduce the risk of electric shock, do not remove the cover (or back) as there are no user-serviceable parts inside. Refer servicing to qualified personnel.
  - The exclamation point within an equilateral triangle is intended to alert the user to the presence of important operating and maintenance instructions in the literature accompanying the appliance.
20.  (Protective earthing terminal) The apparatus should be connected to a mains socket outlet with a protective earthing connection.
21.  Correct Disposal of this product. This marking indicates that this product should not be disposed with other household wastes throughout the EU. To prevent possible harm to the environment or human health from uncontrolled waste disposal, recycle it responsibly to promote the sustainable reuse of material resources. To return your used device, please use local return and collection systems or contact the retailer where the product was purchased. They can take this product for safe environmentally friendly recycling.

# TABLE OF CONTENTS

- 1.....Important Warnings & Safety Instructions
- 2.....Important Safety Information Powered Products
- 4.....Introduction / About the Titan™ Series
- 4.....Titan series overview
- 5.....Features
- 6.....Qubit
- 7.....Setting up / Speaker Placement
- 7.....Connections / Wiring - Passive
- 8.....Rear Panel Layout - Passive
- 8.....Connection Diagram - Passive
- 11.....Rear Panel Layout - Active
- 14.....Connection Diagram - Active
- 15.....Rear Panel Layout - Sub A12
- 16.....Connection Diagram - Sub A12
- 18.....Rear Panel Layout - Sub 15A MKII
- 19.....Connection Diagram - Sub 15A MKII
- 21.....Specifications - Titan™ Passive
- 22.....Specifications - Titan™ Active
- 24.....Specifications - Titan™ Subwoofers
- 25.....Dimensional Drawings - Titan™ 8 / 12
- 26.....Dimensional Drawings - Titan™ 15 / 8A MKII
- 27.....Dimensional Drawings - Titan™ 12D / 15D
- 28.....Dimensional Drawings - Titan™ Sub A12 / 15A MKII
- 29.....Warranty



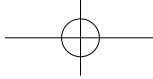

## INTRODUCTION

Wharfedale Pro Titan™ Series is the result of many years of experience in the use, design and manufacturing of professional loudspeaker products. We take great pride in engineering and building every Wharfedale Pro loudspeaker and wish to thank you for entrusting us with your sound.

From the time Gilbert Briggs built his first loudspeaker in 1932, to the present, Wharfedale Loudspeakers have maintained the same standard of quality in components, workmanship and performance. Wharfedale are one of the few present day manufacturers that design, engineer and build all of our own transducers.

Please take a few minutes to read this manual completely in order to ensure that you get the most out of your Titan™ Series Loudspeaker system.

## TITAN™ SERIES OVERVIEW

The Titan Series are powerful, accurate, high quality loudspeaker systems with low distortion that are designed to deliver outstanding performance at a cost effective price point. An Elliptical Wave Guide (EWG) is perfectly matched to the custom designed HF drivers and provides smooth dispersion in both the horizontal and vertical planes.

The road tough, gas-assist injection moulded polypropylene enclosures are ultra lightweight and include rubberised handles and cable management to make Titan the most user-friendly portable speaker on the market. Threaded rigging points mean that Titan is equally suited to flown applications; a comprehensive range of Wharfedale Pro wall mounting options are also available as optional extras.

Active models feature rear panel power LED's and a throat mounted LED to make you aware of AC power supply from both the front and rear of the unit. Active models also feature a horn LED defeat switch for less obtrusive aesthetics in applications such as conferencing and A/V presentations. The BRO™ (Bass Response Optimizer) circuit on the 12D and 15D models helps counteract loss of bass at low levels, similar to a loudness switch on home HiFi amplifiers. In addition our "D" models feature Qubit™ 24-bit 192kHz DSP Processing.

## FEATURES

### Titan Passive

- ◆ 2-way full range loudspeakers
- ◆ Low distortion, high power moisture proof woofers
- ◆ HF compression drivers
- ◆ 90° x 60° Elliptical Wave Guide (EWG)
- ◆ DTF™ Dynamic Thermal Filament HF protection
- ◆ Lightweight, high strength gas-assist injection moulded polypropylene enclosures
- ◆ Ergonomic rubberised handles
- ◆ Integral lockable 35mm (1 $\frac{3}{8}$ " ) pole mount socket
- ◆ M6 / M8 rigging points
- ◆ Speakon™ and 1/4" jack inputs

### Titan Active

- ◆ Bi-amplified full range loudspeakers
- ◆ Low distortion, high power moisture proof woofers
- ◆ HF compression drivers
- ◆ Qubit™ 24-bit 192kHz DSP processing
- ◆ Independent LF & HF adaptive dynamics and signal limiting
- ◆ Per channel volume controls (Master only on 8A MKII)
- ◆ 2 Band EQ
- ◆ 90° x 60° elliptical Wave Guide (EWG)
- ◆ BRO™ Bass Response Optimizer (12D & 15D only)
- ◆ Horn LED defeat switch
- ◆ Balanced XLR output for parallel wiring
- ◆ XLR / 1/4" jack combo inputs
- ◆ Mic / line level input selector
- ◆ 2 mixable inputs (12D & 15D only)
- ◆ Stereo RCA inputs (12D & 15D only)
- ◆ Lightweight, high strength gas-assist injection moulded polypropylene enclosures
- ◆ Ergonomic rubberized handles
- ◆ Integral lockable 35mm (1 $\frac{3}{8}$ " ) pole mount socket
- ◆ M6 / M8 rigging points
- ◆ IEC AC receptacle

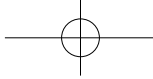

### Subwoofer

- ◆ Low distortion, high power woofers
- ◆ 2x balanced XLR HPF outputs
- ◆ 2x summed XLR / ¼" jack combo inputs
- ◆ Built in signal limiting
- ◆ Adjustable crossover frequency
- ◆  $-\infty$  to +6dB trim control
- ◆ 0° / 180° switch
- ◆ Ergonomic handles
- ◆ Pole mount socket
- ◆ IEC AC receptacle

### QUBIT™

Qubit brings the power and precision of 24-bit 192kHz DSP processing to the next generation of Wharfedale Pro Products.

With advanced multi-band dynamic processing and filtering Qubit helps fine tune your system to sound natural and open. Qubit processing optimises the loudspeaker to provide smooth digital crossover points that are perfectly aligned. Protection is offered in the form of true independent adaptive LF and HF signal limiting that helps protect against thermal damage and driver over excursion.

Qubit has an extended frequency response that goes way beyond the capabilities of our hearing, providing an extended phase response that remains linear throughout our natural hearing range. A Qubit equipped system can reproduce exceptionally natural and accurate transients due to its phase characteristics and perfect time alignment.

## SETTING UP

1. Ensure the speakers power switch is in the off position (Active models only)
2. Set the level controls to minimum (Fully anticlockwise) (Active models only)
3. Set the EQ controls to 0dB (Active models only)
4. Select mic/line input (Active models only)
5. Connect all signal cables
6. Connect the power cable (Active models only)
7. Switch on source equipment, ensuring that the master level is at minimum
8. Switch on the Titan Loudspeaker (Active models only)
9. Raise the level control on the Titan (Active models only) or external amplifier
10. If the limit LED illuminates lower the level control, if more level is required you will need more speakers. Occasional flashes are acceptable. (Active models only)
11. When powering down your system ensure that the level control (Active models only) has been lowered to minimum before switching off the power

## SPEAKER PLACEMENT

The well behaved dispersion characteristics of the Titan series make speaker placement quick and simple.

As with all full range loudspeakers it is recommended to place a Titan above the head level of the audience, as the human body can absorb a huge amount of high frequency energy. Placing the loudspeaker enclosure higher up also helps improve coverage for more even levels over a greater audience area.

Tripod speaker stands, pole mounts, Wall brackets and rigging hardware can be used to elevate the Titan loudspeaker. Always ensure that any accessories that are used are capable of safely elevating the loudspeaker as incorrect rigging can be dangerous and even fatal. Please refer to the important safety warnings section for more guidelines on rigging and suspending.

Always place your microphones outside the coverage of your front of house speakers to reduce the risk of feedback.

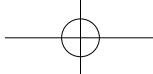

Titan™ REAR PANEL LAYOUT

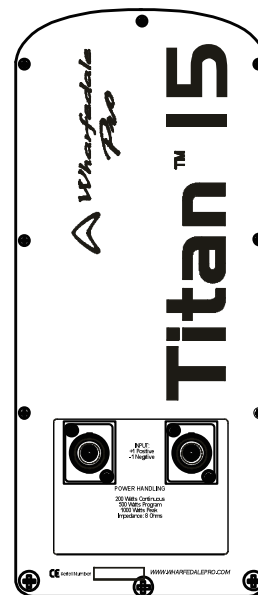
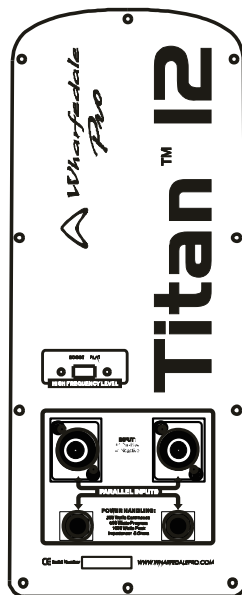
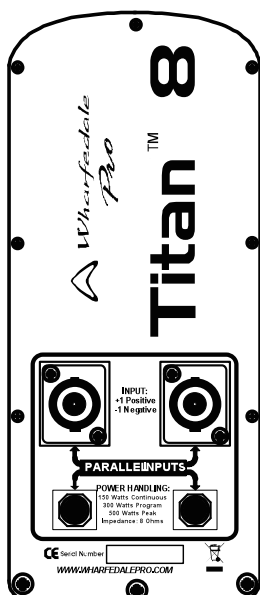

CONNECTION DIAGRAM #1

Titan two channel setup

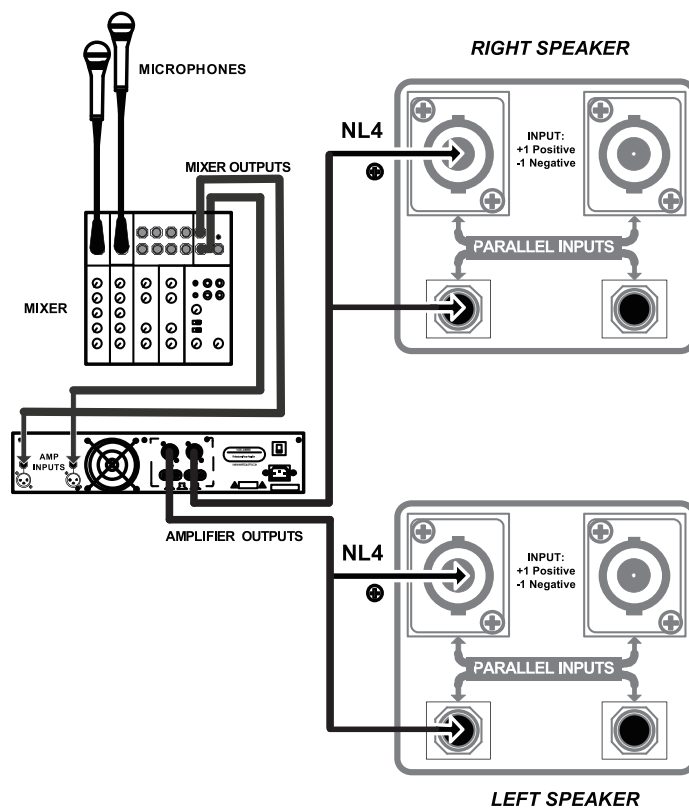

# OPERATING MANUAL AND USER GUIDE

## CONNECTION DIAGRAM # 2

Titan mono front of house+stage monitor setup

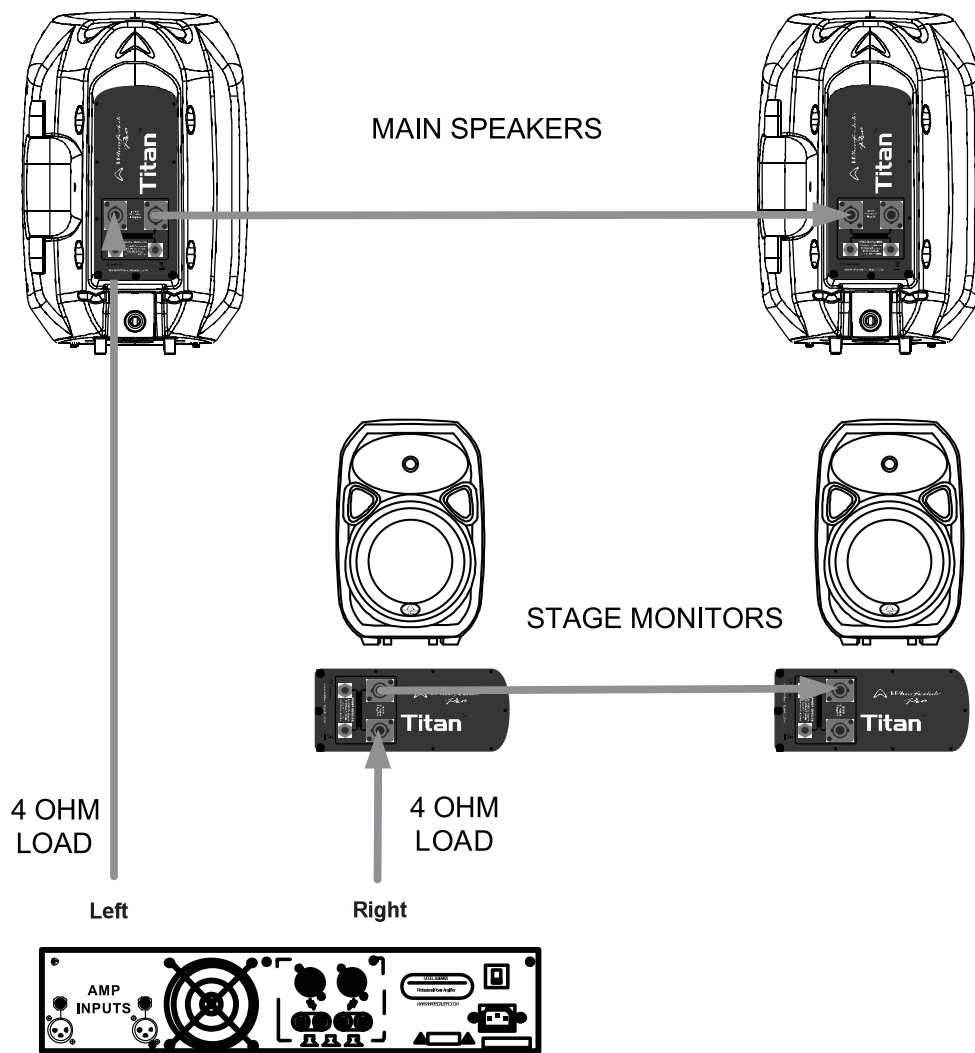

**NOTE:** This configuration represents a 4 ohm load to each output channel of the amplifier



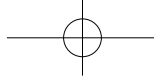

**CONNECTION DIAGRAM # 3**

USING THE Titan WITH A PASSIVE SUBWOOFER

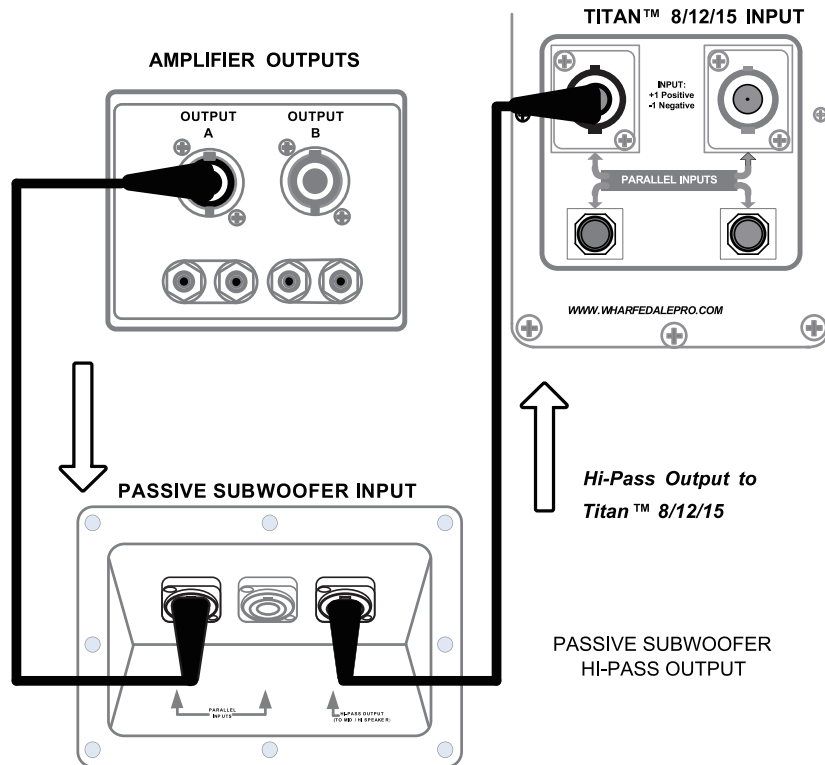

**CONNECTION DIAGRAM # 4**

USING THE Titan™ 8/12/15 IN A BI-AMP SYSTEM

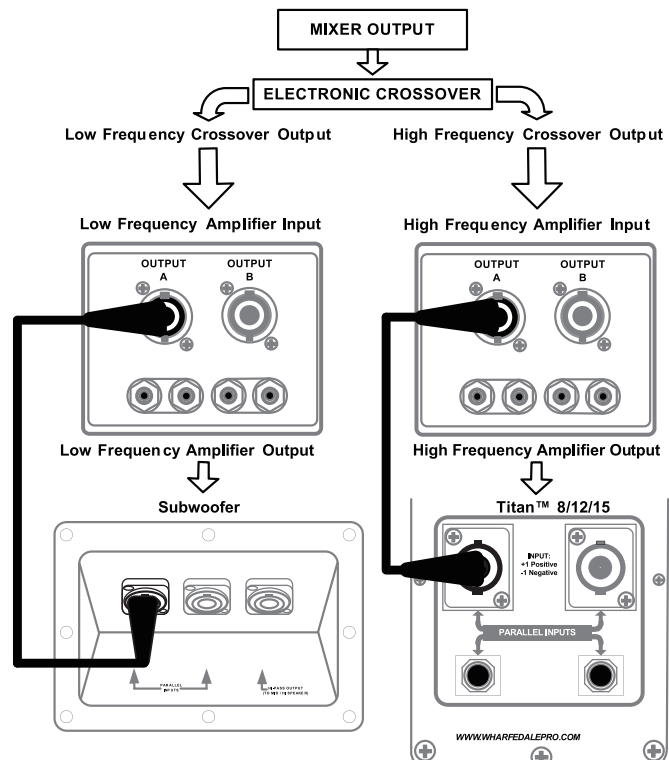

**Titan™ 8A MKII / Titan™ 12D / Titan™ 15D**

**The Loop / Mix Switch**

The LOOP/MIX switch allows you to control the signal content going to the XLR OUTPUT jack. In the “LOOP” mode, this switch routes the signal of INPUT B to the line level XLR OUTPUT jack, bypassing the EQ section and volume control. When in the MIX mode, this switch routes the combined (or “mixed”) signals of both INPUT A and INPUT B to the line level XLR OUTPUT jack. This signal can then be sent to additional powered speakers or powered subwoofers.

**8A MKII - REAR PANEL FEATURES**

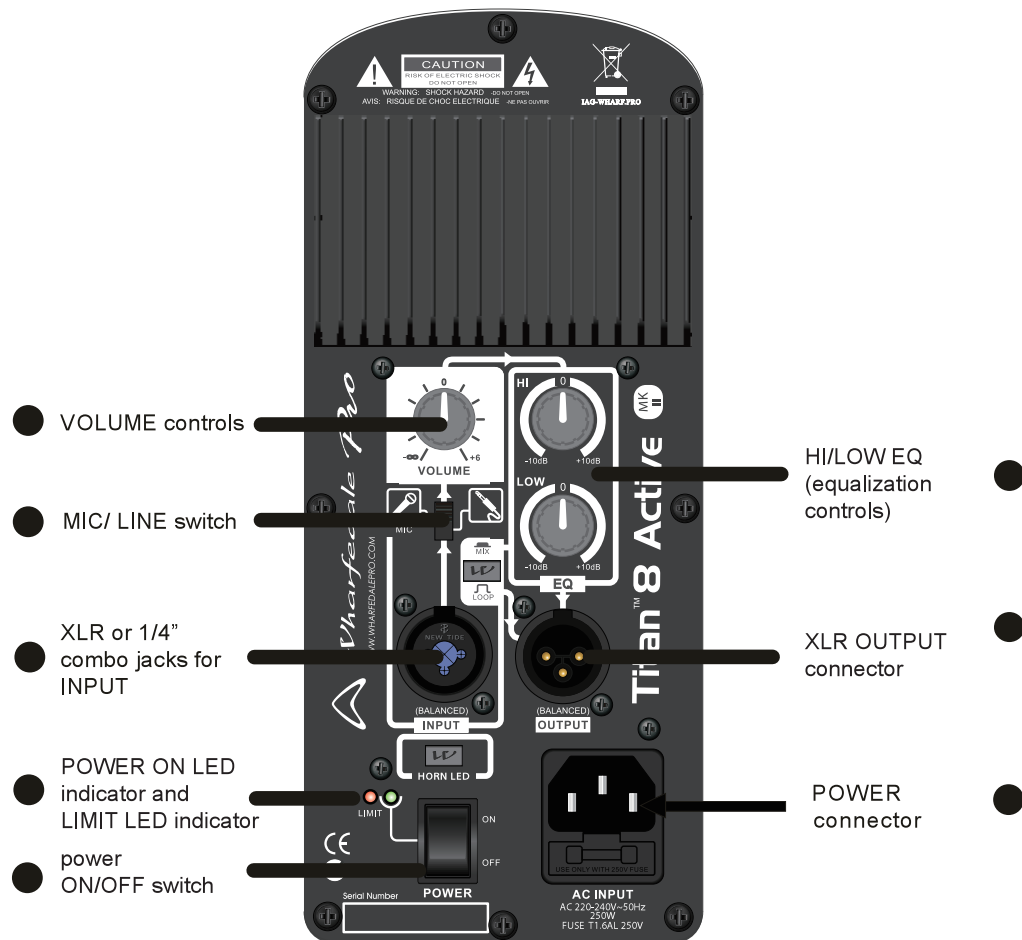

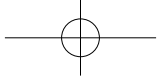

**Titan™ 12D/15D REAR PANEL LAYOUT**

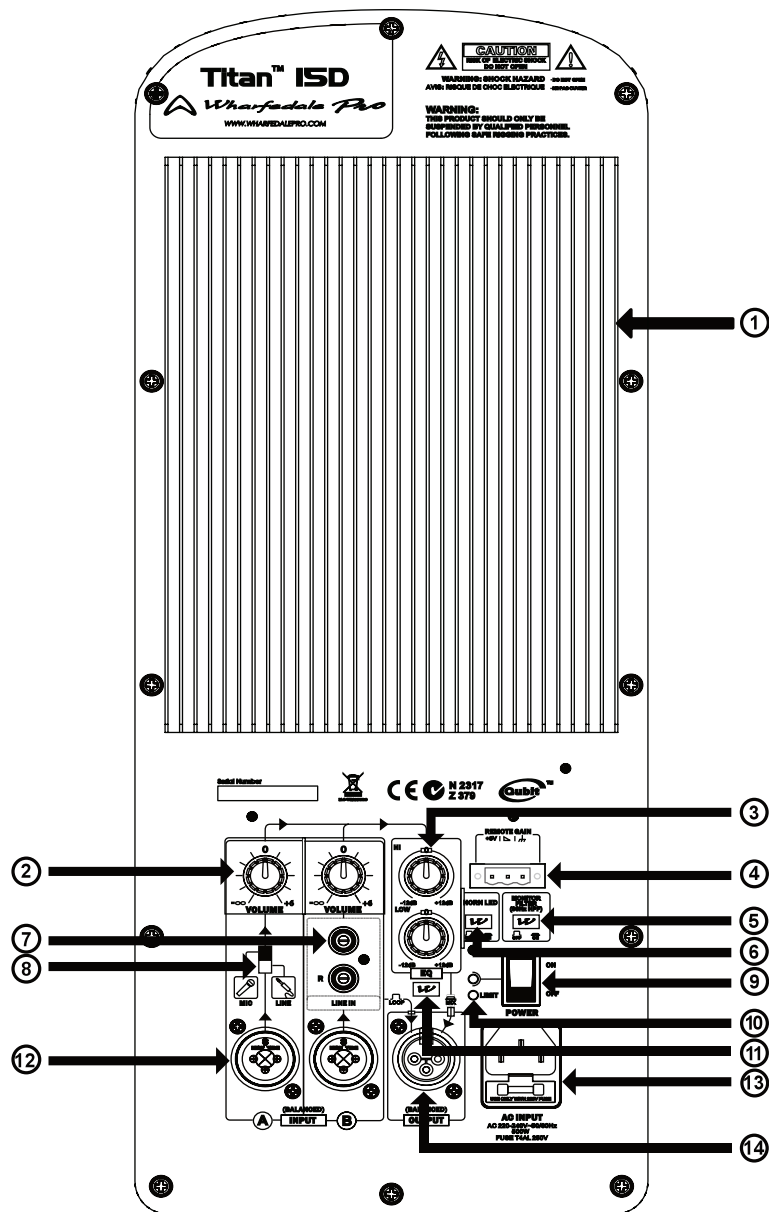

## TITAN™ 8A MKII/12D/15D REAR PANEL FEATURES

1. **Heat Sink:** The heat sink allows for dissipation of heat built up from the amplifier via air cooling at the rear of the enclosure. (Titan 8A MKII and 15D only)
2. **VOLUME for INPUT A and INPUT B:** These knobs control the level of each input channel (Controls the master volume on the Titan 8A MKII)
3. **HI and LOW EQ (equalization) controls:** These knobs control the equalization of the overall output signal providing +/- 10dB of gain for each band.
4. **Remote Control:** This Phoenix connector can be used to control the volume with an applied voltage.
5. **90Hz Monitor Filter switch:** Used to reduce bass buildup due to half space loading.
6. **Horn LED defeat switch:** Switches off the horn power LED for discrete applications.
7. **RCA L / R (Left and Right) input jacks:** These jacks allow input of a stereo signal (left and right). The signal is actively combined or "summed" providing a mono signal to the amplifier.
8. **GAIN selection switch:** This switch selects the proper gain structure for INPUT A. If a microphone is connected to INPUT A, use mic mode (up). If the signal source is anything other than a microphone (playback device, keyboard or mixer output, for instance) use the line mode (down) .
- 9 & 10. **POWER ON / OFF switch, POWER 'ON' indicator LED and LIMIT indicator LED:** The switch: turns the power on and off. The bracketed LED to the left of the POWER switch illuminates when the power switch is in the 'ON' position. The LIMIT LED illuminates when the signal limiter is limiting the level of the signal to prevent distortion and overload.
11. **Output source "LOOP / MIX" switch:** In the "LOOP" mode, this switch routes the signal of INPUT B to the line level XLR OUTPUT jack, bypassing the EQ section and volume control. When in the MIX mode, this switch routes the combined (or "mixed") signals of both INPUT A and INPUT B to the line level XLR OUTPUT jack.
12. **XLR / ¼" COMBO input jacks for INPUT A and INPUT B:** These convenient jacks allow XLR or ¼" balanced input connections to INPUT A and INPUT B
13. **POWER cord receptacle:** This is a receptacle for a standard IEC, three prong, grounded AC electrical connection cord. Be sure that you are plugging into the correct source voltage that matches what is indicated just below the power cord jack.
14. **XLR line level OUTPUT jack:** This jack provides a balanced line level output for connection to additional Titan™ ACTIVES, powered subwoofers or amplifiers.

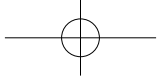

**Titan™ 12D / 15D CONNECTION DIAGRAM # 1**

Basic microphone / playback hookup

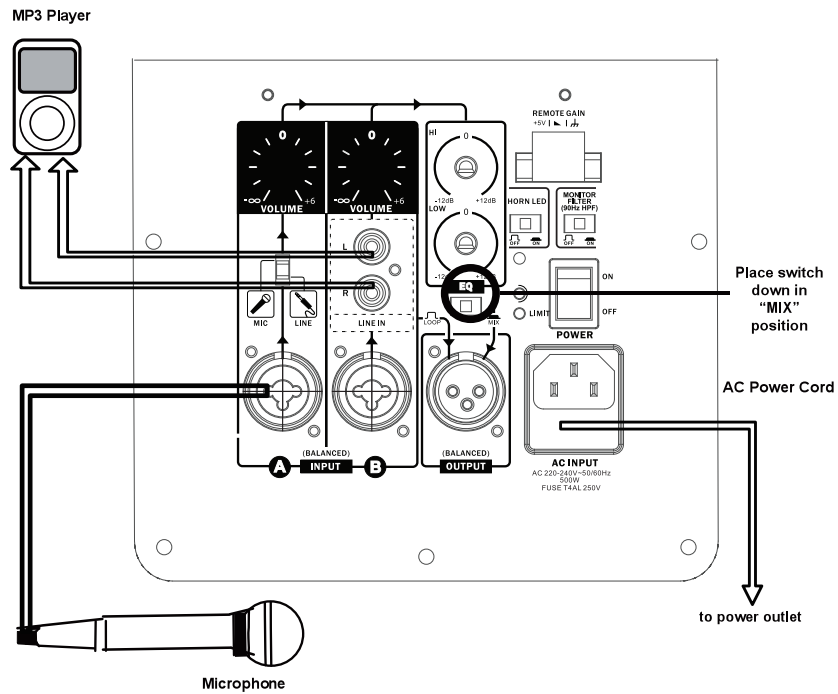

**Titan™ 12D / 15D CONNECTION DIAGRAM # 2**

Connecting two Titan™ ACTIVE speakers together

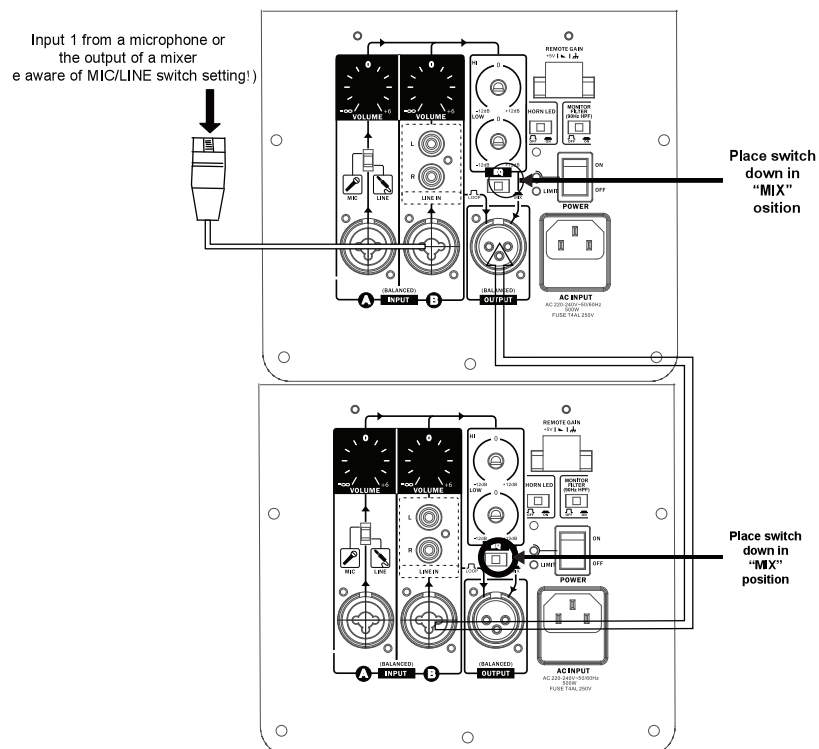

## TITAN™ SUB A12 REAR PANEL FEATURES

- |  |   |
|--|---|
| <b>1. HEAT SINK</b>                    | Cooling fins for amplifier. Do not obstruct.  |
| <b>2. VOLUME CONTROL</b>               | Adjusts the volume.   |
| <b>3. INPUT L</b>                      | Balanced line level input via a XLR/ ¼" combo connector.  |
| <b>4. INPUT R</b>                      | Balanced line level input via a XLR/ ¼" combo connector.  |
| <b>5. OUTPUT R</b>                     | Balanced male XLR connector provides output HIGHPASS signal.  |
| <b>6. OUTPUT L</b>                     | Balanced male XLR connector provides output HIGHPASS signal.  |
| <b>7. POWER SOCKET</b>                 | This is the connection for the IEC AC power connector.  |
| <b>8. LIMIT LED</b>                    | LED indicator illuminates when the signal limiting function is activated.   |
| <b>POWER LED</b>                       | LED indicator illuminates when the unit is powered up.  |
| <b>9. POWER SWITCH</b>                 | Turns the power on and off to the subwoofer amplifier module.   |
| <b>10. PHASE SWITCH</b>                | Selects the polarity of the signal being sent to the subwoofer.<br><br>0° selects the signal polarity as it appears at the input.<br><br>The 180° selection inverts the polarity of the signal. |
| <b>11. CROSSOVER FREQUENCY CONTROL</b> | Adjustable 80Hz/100Hz/120Hz/150Hz/180Hz/200Hz.  |

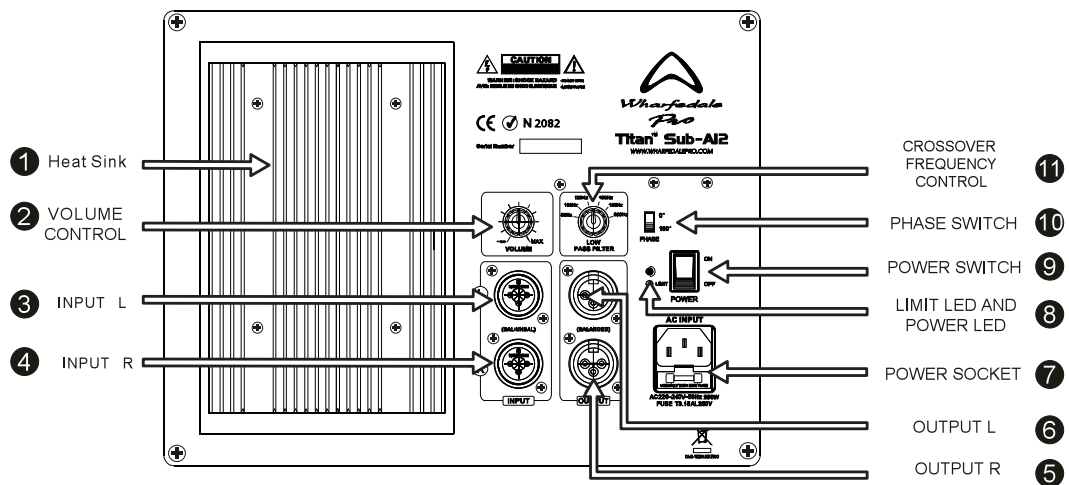



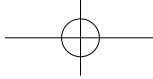

**Titan™ Sub-A12 CONNECTION DIAGRAM # 1**

TWO CHANNEL SYSTEM WITH HIGHPASS OUTPUT

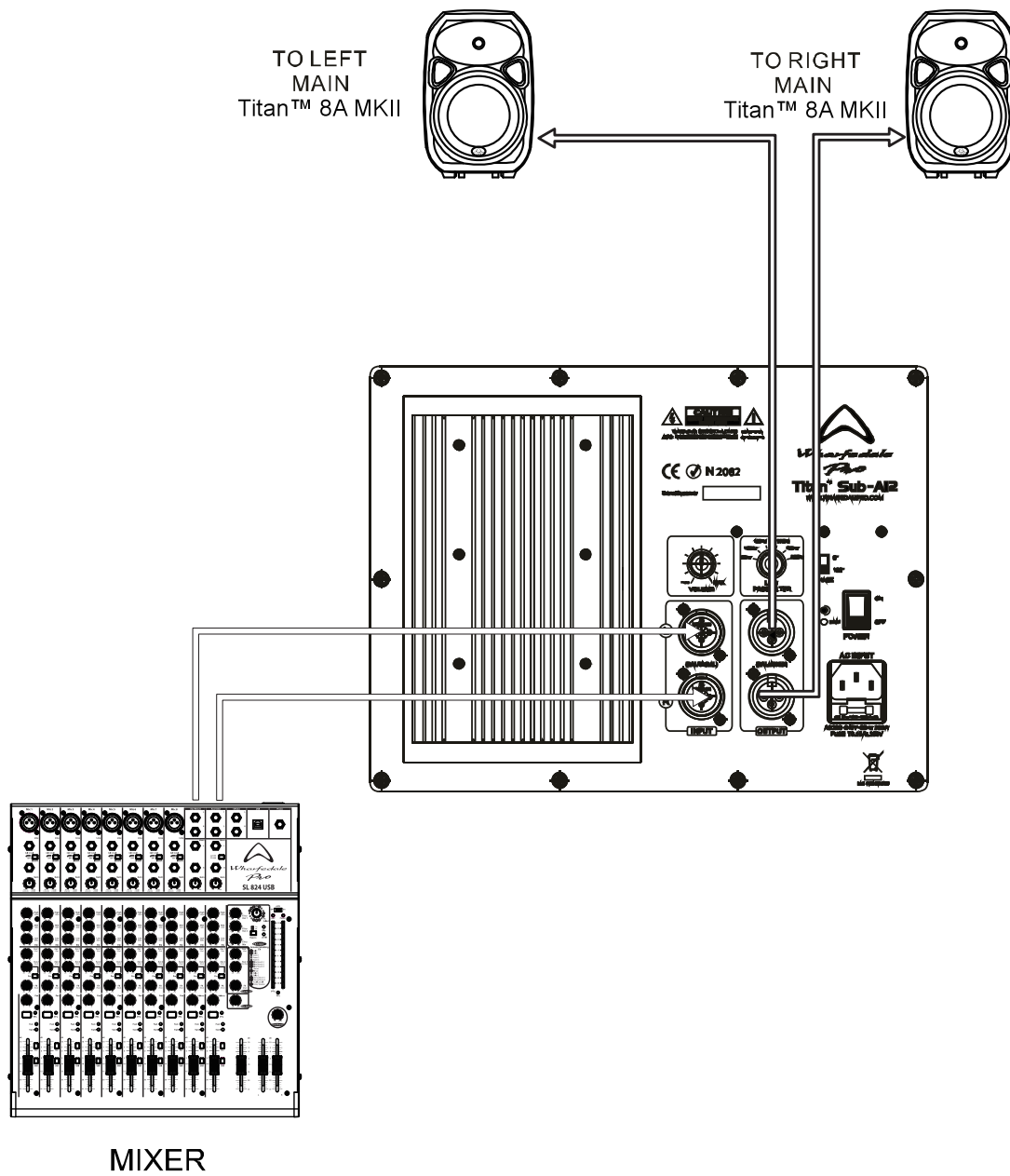

# OPERATING MANUAL AND USER GUIDE

## Titan™ Sub-A12 CONNECTION DIAGRAM # 2

USING TWO Titan™ Sub-A12 WITH  
TWO POWER SPEAKERS

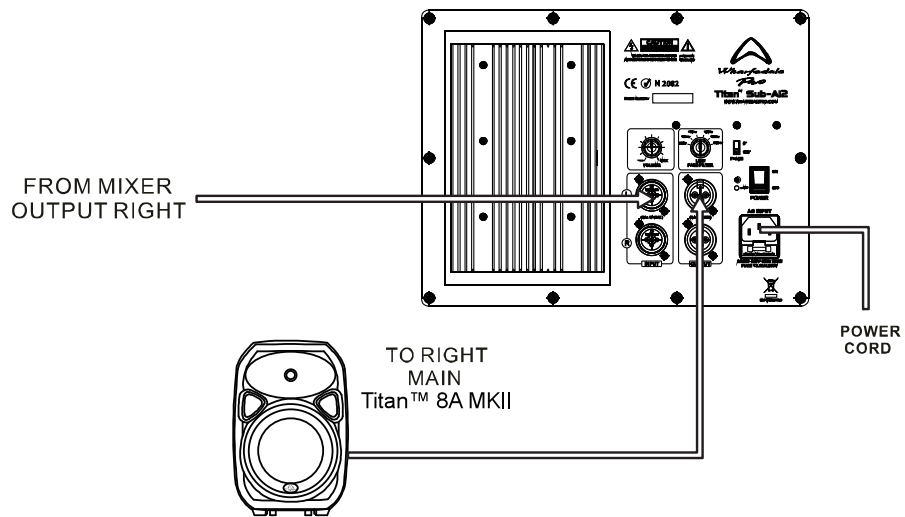
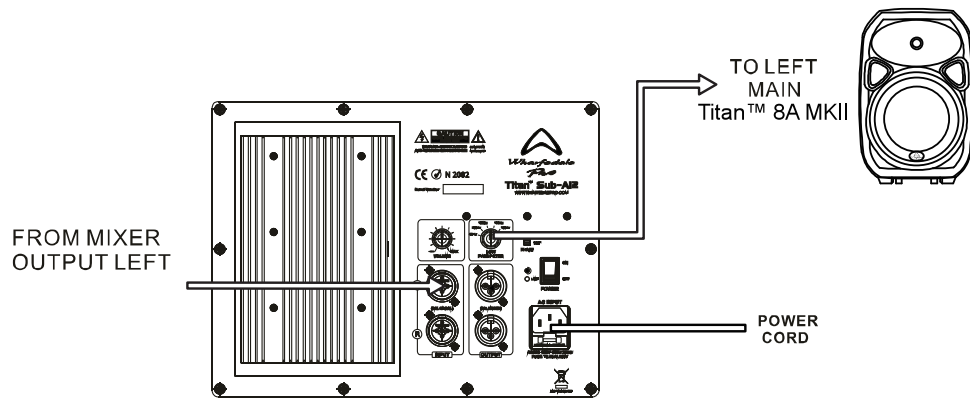

## Titan™ SUB 15A MKII REAR PANEL FEATURES

1. **HEAT SINK** : Cooling fins for amplifier. Do not obstruct.
2. **VOLUME CONTROL** : Adjusts the volume
3. **INPUT A**: TRS JACK and MALE XLR balanced for INPUT A.
4. **INPUT B**: TRS JACK and MALE XLR balanced for INPUT B.
5. **OUTPUT A**: Balanced male XLR connector provides output HIGHPASS signal. Selects the signal type that is routed to the OUTPUT jack, "THRU" sends the unprocessed signal to the outputs. "HIGH PASS" filters the signal at 100Hz to the outputs.
6. **OUTPUT B**: Balanced male XLR connector provides output HIGHPASS signal. Selects the signal that is routed to the OUTPUT jack, "THRU" sends the unprocessed signal to the outputs. "HIGH PASS" filters the signal at 100Hz to the outputs.
7. **POWER SOCKETS**: This is the connection for the IEC AC power connector.
8. **LIMITED LED**: LED indicator illuminates when the signal limiting function is activated.
9. **POWERED LED**: LED indicator illuminates when the unit is powered up.
10. **POWER SWITCH** : Turns the power on and off to the subwoofer amplifier module.
11. **PHASE SWITCH**: Selects the polarity of the signal being sent to the subwoofer.  
0° selects the signal polarity as it happens at the input.  
The 180° selection inverts the polarity of the signal.
12. **CROSSOVER**: Adjustable 80Hz to 200Hz.

**FREQUENCY CONTROL**

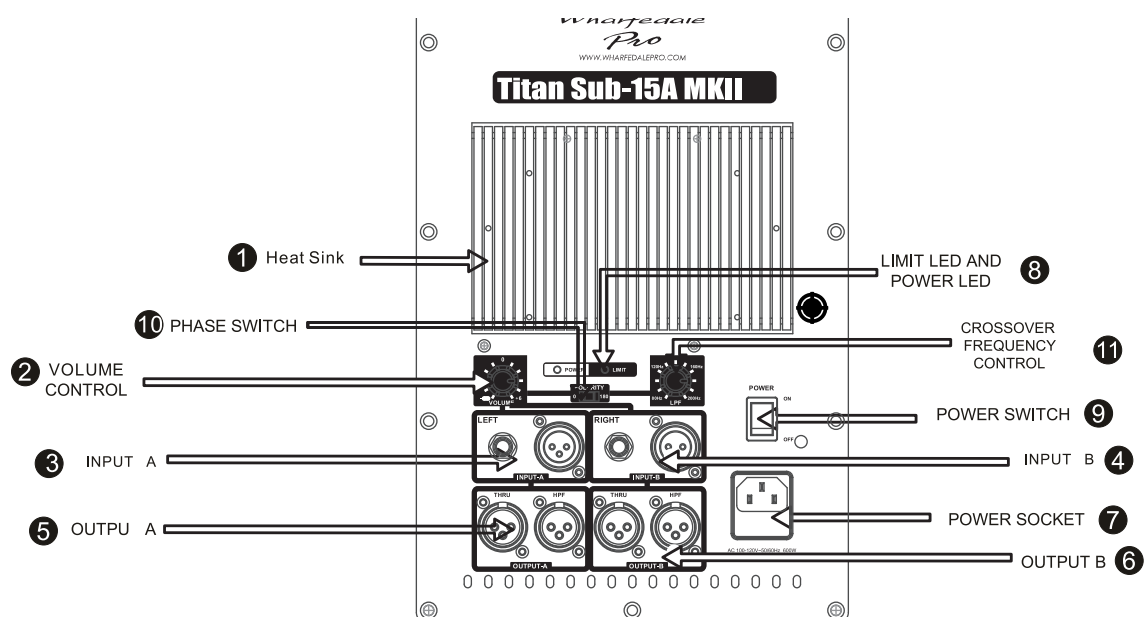

# OPERATING MANUAL AND USER GUIDE

## Titan™ SUB 15A MKII CONNECTION DIAGRAM#1

TWO CHANNEL SYSTEM WITH  
HIGHPASS OUTPUT

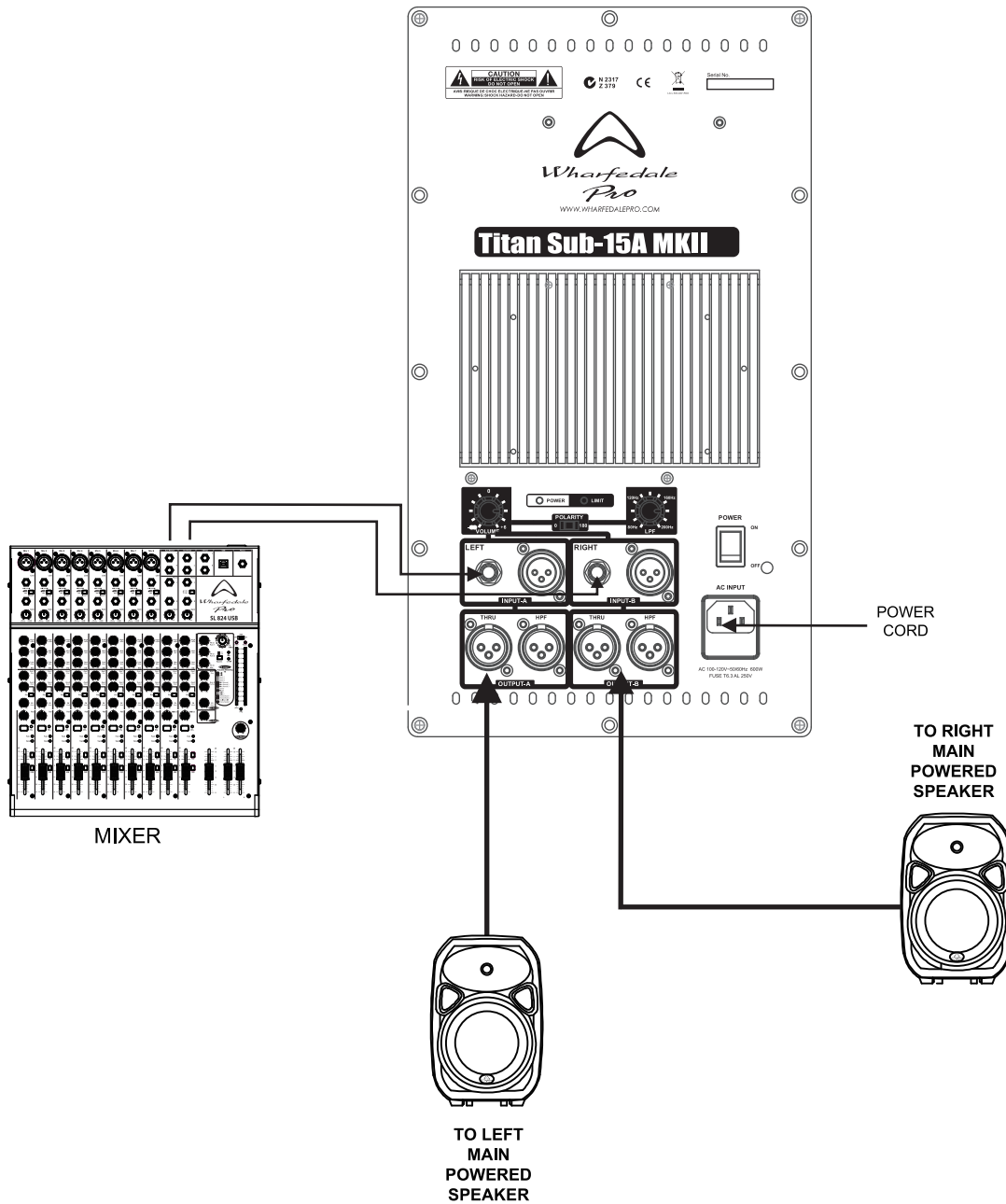

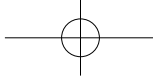

**CONNECTION DIAGRAM # 2**

USING TWO Titan™ SUB 15A MKII's  
WITH TWO POWERED SPEAKERS

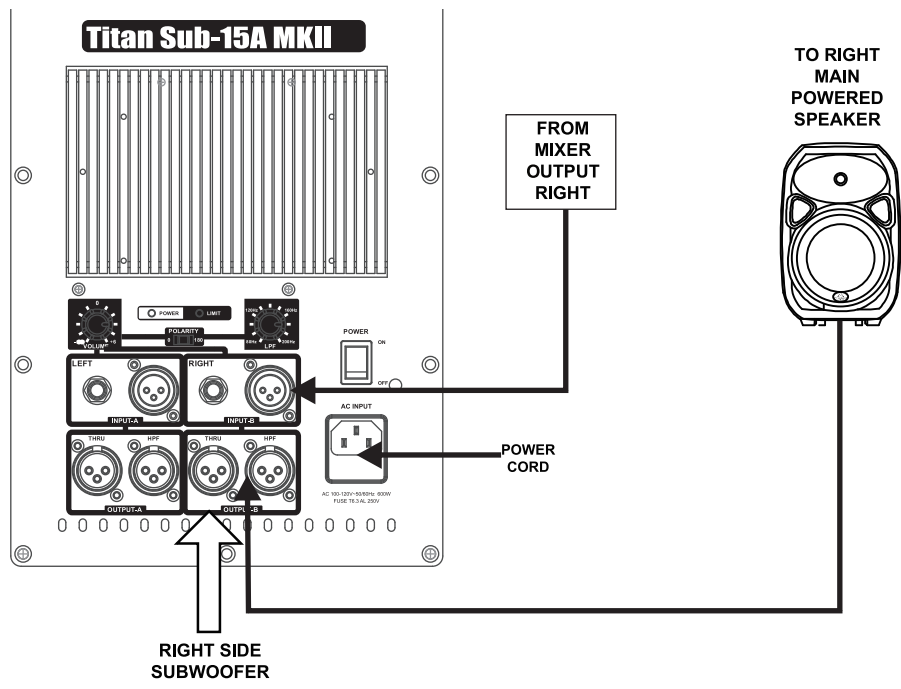
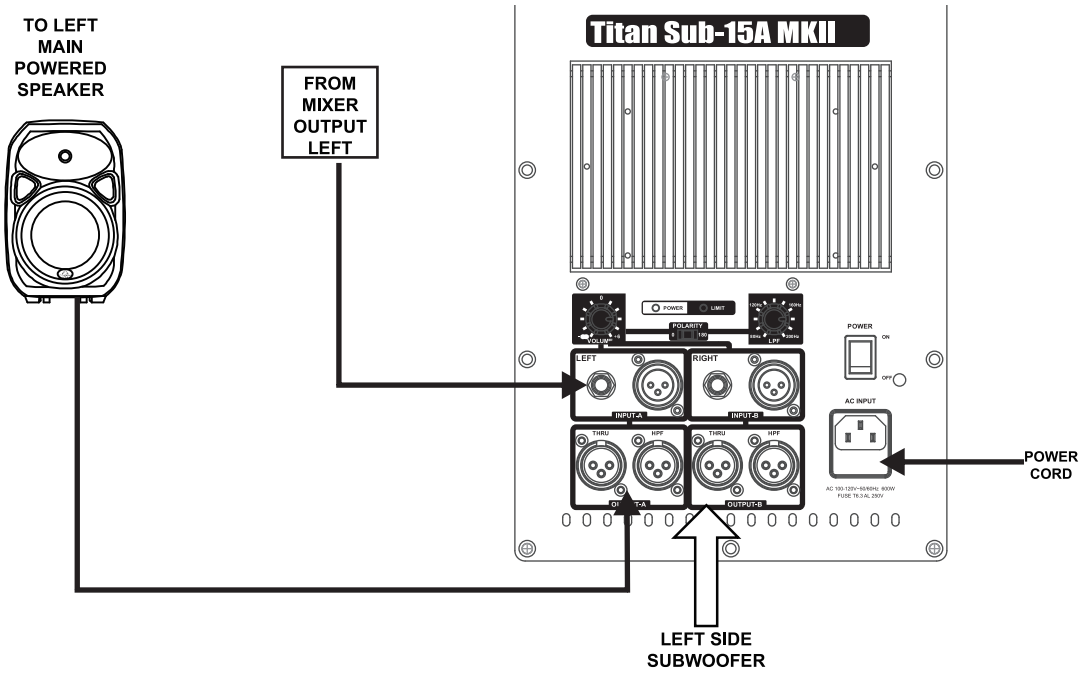

## SPECIFICATIONS - Titan™ PASSIVE SERIES

	Titan™ 8	Titan™ 12	Titan™ 15
<b>Loudspeaker Type:</b>	8" 2-way	12" 2-way	15" 2-way
<b>Frequency Response (+/-3dB):</b>	70 - 20kHz	55 - 20kHz	50 - 20kHz
<b>Sensitivity (1W@1M):</b>	96dB	98dB	97dB
<b>Peak SPL:</b>	124dB	128dB	129dB
<b>HF Coverage (H x V):</b>	90° x 60°	90° x 60°	90° x 60°
<b>System Impedance:</b>	8 ohm	8 ohm	8 ohm
<b>POWER (WATTS)</b>			
<b>Continuous:</b>	150W	250W	400W
<b>Music:</b>	300W	500	800W
<b>Peak:</b>	600W	1000	1600W
<b>LF DRIVER</b>			
<b>Size:</b>	203mm/ 8"	305mm/ 12"	381mm/ 15"
<b>Coil Size:</b>	38.86mm / 1.53"	64.26mm / 2.5"	75mm / 3.0"
<b>HF DRIVER/ HORN</b>	Compression Driver	Compression Driver	Compression Driver
<b>Coil Size:</b>	25mm/1"	44mm/1.75"	51mm/ 2.0"
<b>Exit Size:</b>	30mm/1.2"	25mm/1"	25mm/1"
<b>Diaphragm Material:</b>	Cloth	Titanium	Titanium
<b>HF Driver Protection:</b>	Bulb	DTF™ Dynamic Thermal Filament	DTF™ Dynamic Thermal Filament
<b>Long-Throw EQ Compensation:</b>	N/A	3dB boost (long-throw) / Flat (near-field)	N/A
<b>Horn Type:</b>	EWG™ - Elliptical Waveguide	EWG™ - Elliptical Waveguide	EWG™ - Elliptical Waveguide
<b>Throat Size:</b>	25mm/1"	25mm/1"	25mm/1"
<b>CROSSOVER</b>			
<b>Type/Frequency/Filter:</b>	2-way 2.4KHz / Linkwitz-Riley	2-way 2.2KHz / Linkwitz-Riley	2-way 1.8KHz / Linkwitz-Riley
<b>ENCLOSURE</b>			
<b>Shape/ Material:</b>	Trapezoidal/ Polypropylene	Trapezoidal/ Polypropylene	Trapezoidal/ Polypropylene
<b>Rigging:</b>	(8) M6 threaded rigging points + (4) M6 threaded rigging points on bottom in Omnimount® 30.0-type footprint + Speaker pole-mount receptacle with lock screw + 1 built-in carry handle + Optional wall-mount bracket + (Optional dual-unit array speaker stand hardware)	(10) M8 threaded rigging points + (4) M8 threaded rigging points on bottom in Omnimount® 60.0-type footprint + Speaker pole-mount receptacle with lock screw + Optional wall-mount bracket + (Optional dual-unit array speaker stand hardware)	(10) M8 threaded rigging points + (4) M8 threaded rigging points on bottom in Omnimount® 60.0-type footprint + Speaker pole-mount receptacle with lock screw + Optional wall-mount bracket + (Optional dual unit array speaker stand hardware)
<b>COLOURS</b>	Grey or Black or White	Grey or Black or White	Grey or Black or White
<b>OUTPUT CONNECTORS</b>	2 x 1/4" jacks + 2 x NL4	2 x 1/4" jacks + 2 x NL4	2 x 1/4" jacks + 2 x NL4
<b>DIMENSIONS/WEIGHTS</b>			
<b>Weight:</b>	5.5kg / 12.1lbs	12kg / 26.4lbs	22kg / 48.4lbs
<b>Dimensions (H x W x D):</b>	396 x 266 x 221mm/ 15.59" x 10.47" x 8.7"	556 x 384 x 312mm/ 21.88" x 15.1" x 12.3"	708.3 x 477.8 x 401.77mm/ 27.9" x 18.8" x 15.8"



## SPECIFICATIONS - Titan™ ACTIVE SERIES

	Titan™ 8 ACTIVE MK II	Titan™ 12 D	Titan™ 15 D
<b>System Type</b>	Active 8" 2-way Bi-Amplified	Active 12" 2-way Bi-Amplified	Active 15" 2-way Bi-Amplified
<b>Frequency Response (+/-3dB)</b>	70-20kHz	55-20kHz	50-20kHz
<b>Low Frequency Driver (mm/in.)</b>	205mm / 8"	305mm / 12"	381mm / 15"
<b>High Frequency Driver</b>	Compression Driver	Titanium Compression Driver	Titanium Compression Driver
<b>Exit Size (mm / inches)</b>	30mm / 1.2"	25mm / 1"	25mm / 1"
<b>Dispersion (H x V)</b>	90° x 60°	90° x 60°	90° x 60°
<b>Amplifiers</b>			
<b>Low Frequency (Class D)</b>	Rated 150W continuous, 300W Peak	Rated 250W continuous, 500W Peak	Rated 350W continuous, 700W Peak
<b>High Frequency (Class D)</b>	Rated 30W continuous, 60W Peak	Rated 50W continuous, 100W Peak	Rated 70W continuous, 140W Peak
<b>Electronic Crossover:</b>	24dB per octave Linkwitz-Riley	24dB/octave Linkwitz-Riley	24dB/octave Linkwitz-Riley
<b>Crossover Frequency</b>	2.4kHz	2.3kHz	1.8kHz
<b>Equalization:</b>	High (±10dB) 10kHz Shelving	High (±10dB) 10kHz Shelving	High (±10dB) 10kHz Shelving
	Low (±10dB) 100Hz Shelving	Low (±5dB) 100Hz Shelving	Low (±10dB) 100Hz Shelving
<b>Subsonic Filter</b>	30Hz, Second -order filter	30Hz, Second -order filter	30Hz, Second -order filter
<b>Amplifier Protection</b>			
<b>Power On</b>	Power switch on / off mute	Power switch on / off mute	Power switch on / off mute
<b>Thermal</b>	Amplifier shutdown, auto reset	Amplifier shutdown, auto reset	Amplifier shutdown, auto reset
<b>Low Line Voltage Shut Down</b>	< 80VAC	60% Nominal line voltage	60% Nominal line voltage
<b>Driver Protection</b>	Independent LF and HF limiters	Independent LF and HF limiters	Independent LF and HF limiters
<b>DC Protection</b>	Yes	Yes	Yes
<b>Short Protection</b>	Yes	Yes	Yes
<b>Clip Limiter:</b>	Turns on approx 150W output	Turns on approx 250W output	Turns on approx 350W output
<b>Limiter Indicator</b>	Red LED	Red LED	Red LED
<b>Power Indicator</b>	Green LED	Green LED	Green LED

# SPECIFICATIONS - Titan™ ACTIVE

	Titan™ 8 ACTIVE MKII	Titan™ 12D	Titan™ 15D
<b>Inputs</b>			
<b>Input A - type</b>	Switchable balanced mic or line level input	Switchable balanced mic or line level input	Switchable balanced mic or line level input
<b>Input Sensitivity</b>	Mic: -47dBu (-49.2dBv or 3.4mVrms) Line: 0dBu (-2.2dBv or 0.775Vrms)	Mic: -40dBu (-42.2dBv or 7.75mVrms) Line: 0dBu (-2.2dBv or 0.775Vrms)	Mic: -40dBu (-42.2dBv or 7.75mVrms) Line: 0dBu (-2.2dBv or 0.775Vrms)
<b>Maximum Input Level</b>	+22dBu	+22dBu	+22dBu
<b>Input Connector</b>	XLR - 1/4" Combo jack	XLR - 1/4" Combo jack	XLR - 1/4" Combo jack
<b>Input Impedance</b>	Balanced: 20kΩ - Unbalanced: 10kΩ	Balanced: 10kΩ - Unbalanced: 5kΩ	Balanced: 10kΩ - Unbalanced: 5kΩ
<b>Maximum Input Level</b>	+22dBu	+22dBu	+22dBu
<b>Input B - type</b>	N/A	Line level input	Line level input
<b>Input Sensitivity</b>	N/A	XLR - 1/4" Combo jack: 0dBu (-2.2 dBv or 0.775Vrms) RCA: 0dBu (-2.2dBv or 0.775Vrms)	XLR - 1/4" Combo jack: 0dBu (-2.2 dBv or 0.775Vrms) RCA: 0dBu (-2.2dBv or 0.775Vrms)
<b>Maximum Input Level</b>	+22dBu	+22dBu	+22dBu
<b>Input Connectors</b>	Combo jack: 1/4" - XLR	Combo jack: 1/4" - XLR / Summed dual RCA jacks	Combo jack: 1/4" - XLR / Summed dual RCA jacks
<b>Line Output</b>	Switchable LOOP / MIX Balanced Male XLR Connector	Switchable LOOP / MIX Balanced Male XLR	Switchable LOOP / MIX Balanced Male XLR
<b>Impedance:</b>	Balanced: 1k ohm Unbalanced: 500 ohm	Balanced: 200 ohm Unbalanced: 100 ohm	Balanced: 200 ohm Unbalanced: 100 ohm
<b>Sensitivity</b>	0dBu (-2.2dBv or 0.775Vrms)	0dBu (-2.2dBv or 0.775Vrms)	0dBu (-2.2dBv or 0.775Vrms)
<b>AC Power details</b>			
<b>Power Supply</b>	High Efficiency Switching Mode Power Supply	High Efficiency Switching Mode Power Supply	High Efficiency Switching Mode Power Supply
<b>AC Power Options</b>	AC100~240V, 50 / 60Hz	AC100~120V / 220~240 V, 50 / 60Hz	AC100~120V / 220~240 V, 50 / 60Hz
<b>Power On Indicator</b>	Green LED	Green LED	Green LED
<b>Rigging / Bracket / Mounting Options</b>	8 M6 threaded inserts including 4 M6 threaded inserts on bottom in OmniMount 30.0-type footprint Pole-mount receptacle with lock screw 1 carry handles  Optional wall-mount bracket	10 M8 threaded inserts including 4 M8 threaded inserts on bottom in OmniMount 60.0-type footprint Pole-mount receptacle with lock screw 2 carry handles (one on each side)  Optional wall-mount bracket	10 M8 threaded inserts including 4 M8 threaded inserts on bottom in OmniMount 60.0-type footprint Pole-mount receptacle with lock screw 2 carry handles (one on each side)  Optional wall-mount bracket
<b>Enclosure Material</b>	Injection Moulded Polypropylene	Injection Moulded Polypropylene	Injection Moulded Polypropylene
<b>Colours</b>	Grey or white or black	Black	Black
<b>Dimensions H x W x D (mm)</b>	396 x 266 x 221	556 x 384 x 312	708.3 x 477.8 x 401.8
<b>Dimensions H x W x D (in)</b>	15.6 x 10.5 x 8.7	21.9 x 15.1 x 12.3	27.9" x 18.8" x 15.8
<b>Net Weight (kg / lbs)</b>	6.25kg / 13.75lbs	12.4kg / 27.28lbs	22.9kg / 50.38lbs
<b>Gross Weight (kg / lbs)</b>	8.15kg / 17.93lbs	15.5kg / 34.1bs	27.7kg / 60.94lbs

## SPECIFICATIONS - Titan™ SUB SERIES

	Titan™ Sub-15A MKII	Titan™ Sub-A12
<b>System Type</b>	Optimally-vented 15" subwoofer Active	Reflex subwoofer
<b>Frequency Response (+/-3dB)</b>	45-200Hz	55-200Hz
<b>Enclosure Material</b>	15mm Plywood	15mm MDF
<b>Enclosure Colour</b>	Grey or Black	Grey or Black
<b>Frame material</b>	steel frame	steel frame
<b>Size (mm / inches)</b>	381mm / 15"	305mm / 12"
<b>Coil Size (mm / inches)</b>	4 layer 2.5"	64.26mm / 2.5"
<b>Impedance</b>	4 ohm	4 ohm
<b>Speaker Pole Adapter</b>	Yes	Yes
<b>Inputs A &amp; B - Type / Connection</b>	TRS JACK and MALE XLR	Balanced Line Level inputs via two combo connectors
<b>Output A &amp; B Type / Connection</b>	Balanced and FEMALE XLR	Balanced Line Level inputs via two combo connectors
<b>Input Sensitivity</b>	0.775V	0.37V
<b>High Pass Frequency Selection</b>	100Hz	150Hz
<b>Phase Switch Selection</b>	0° / 180°	0° / 180°
<b>Crossover Frequency (HZ)</b>	LPF 80-200Hz(adjustable)	80/ 100/ 120/ 150/ 180/ 200 (adjustable)
<b>Amplifier Power: Continuous</b>	400W	250W
<b>Amplifier Power: Peak</b>	800W	500W
<b>Power On Indicator</b>	LED	LED
<b>Power On Protection</b>	Power switch on / off mute	Power switch on / off mute
<b>Thermal Protection</b>	Amplifier shutdown, auto reset	Amplifier shutdown, auto reset
<b>Low Line Voltage Shut Down</b>	85% Nominal line voltage	60% Nominal line voltage
<b>Driver Protection</b>	Independent LF limiters	Independent LF limiters
<b>DC Protection</b>	Yes	Yes
<b>Short Protection</b>	Yes	Yes
<b>Clip Limiter:</b>	Turns on approx 400W output	Turns on approx 250W output
<b>Limiter Indicator</b>	Red LED	Red LED
<b>Power Indicator</b>	Green LED	Green LED
<b>Dimensions H x W x D: (mm)</b>	455.0 x 470.0 x 630.0	360.0 x 493 x 431.0
<b>Dimensions H x W x D (in)</b>	17.9 x 18.5 x 24.8	14.2 x 19.4 x 16.9
<b>Weight (Net) kg / lbs</b>	26.0kg / 57.31lbs	22.31kg / 49.0lbs

# DIMENSIONS

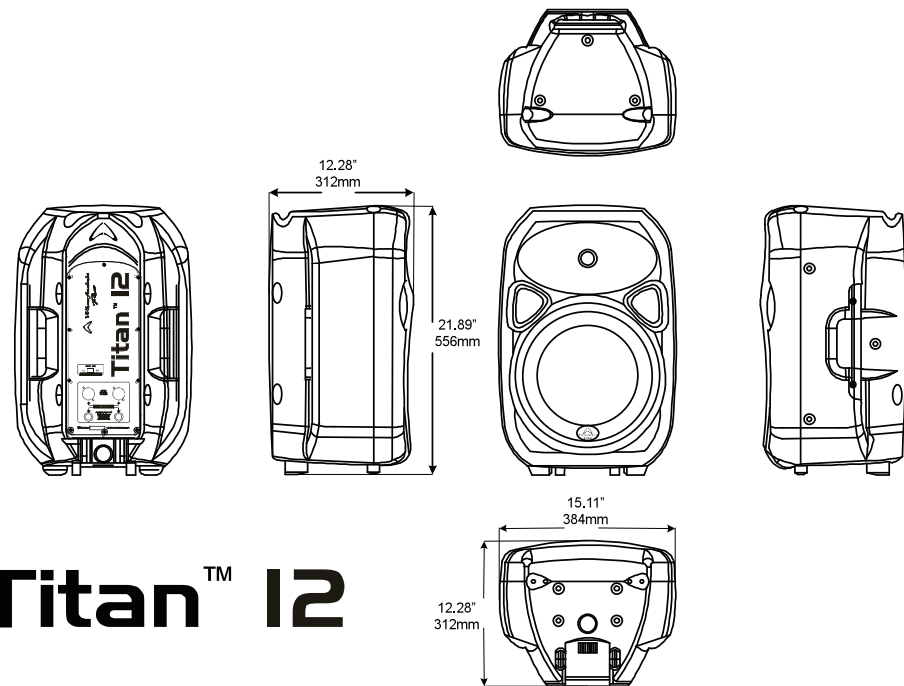
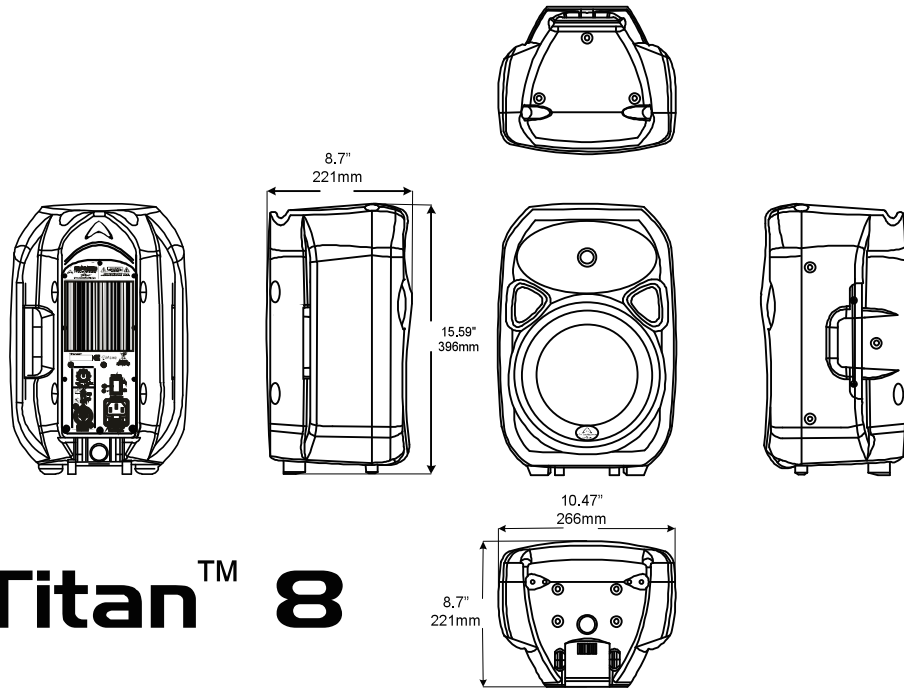

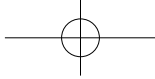

# DIMENSIONS

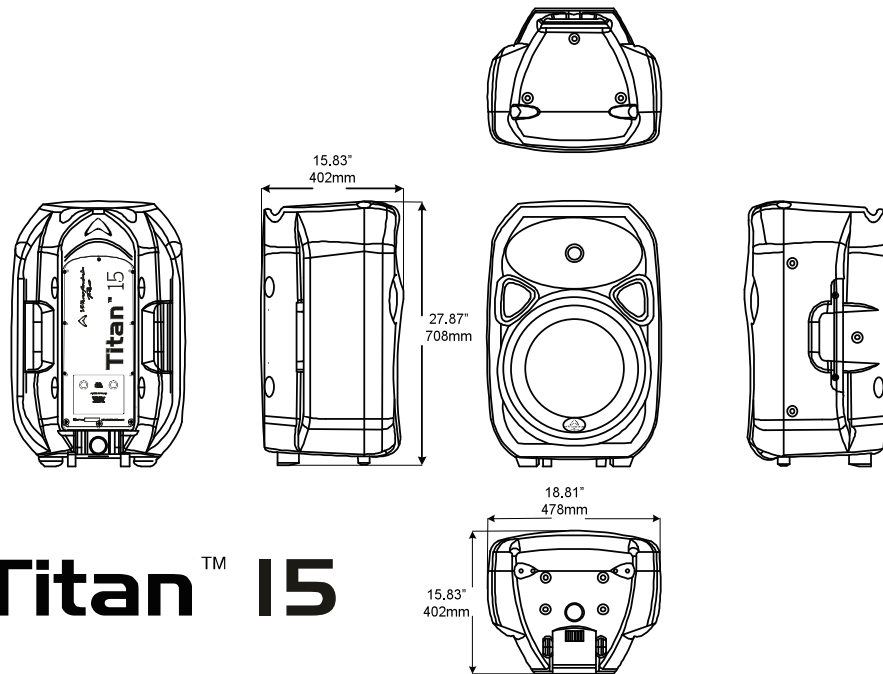

## Titan™ 15

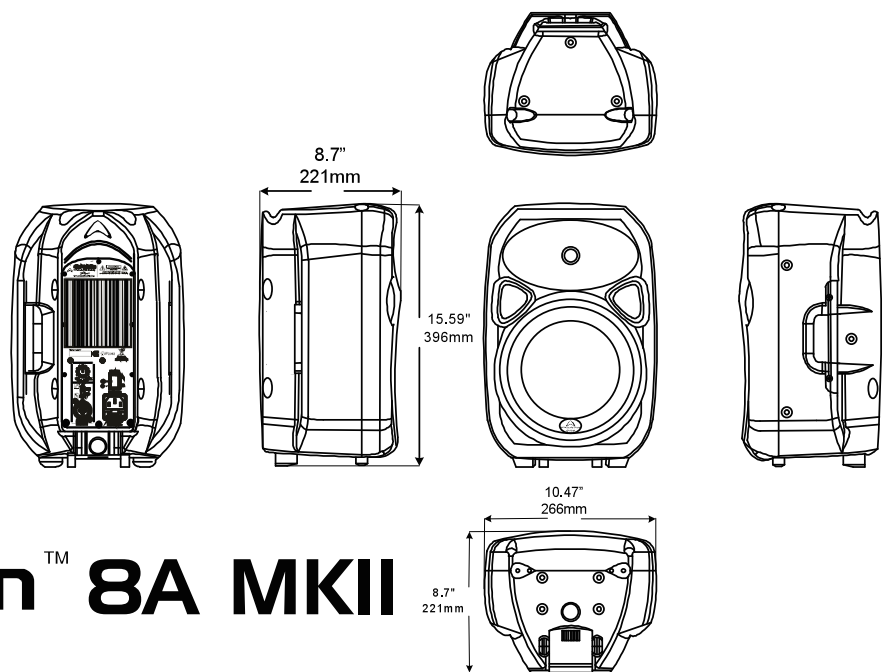

## Titan™ 8A MKII

# DIMENSIONS

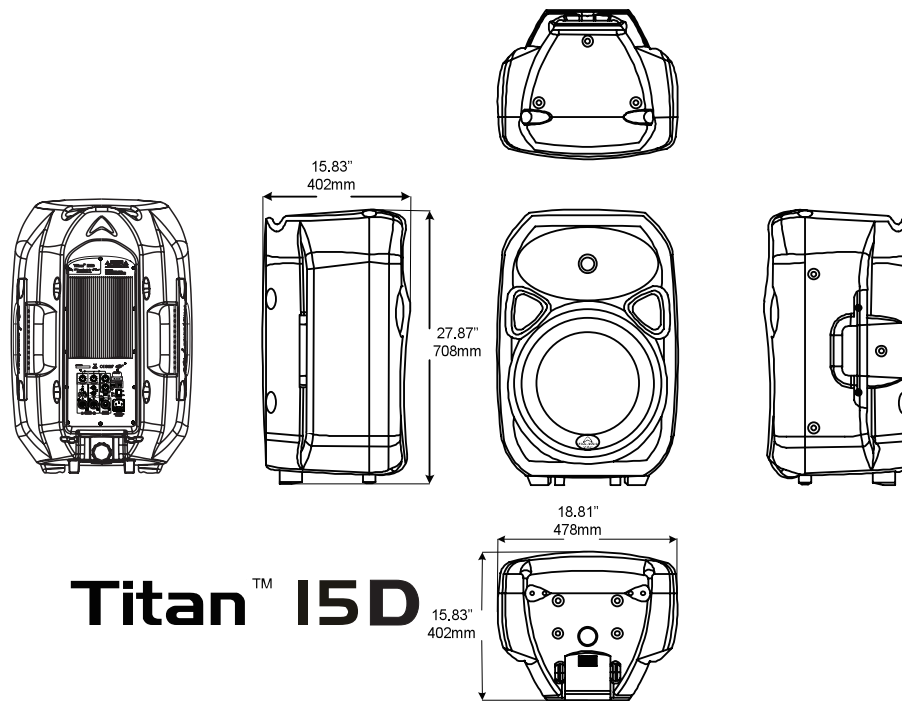
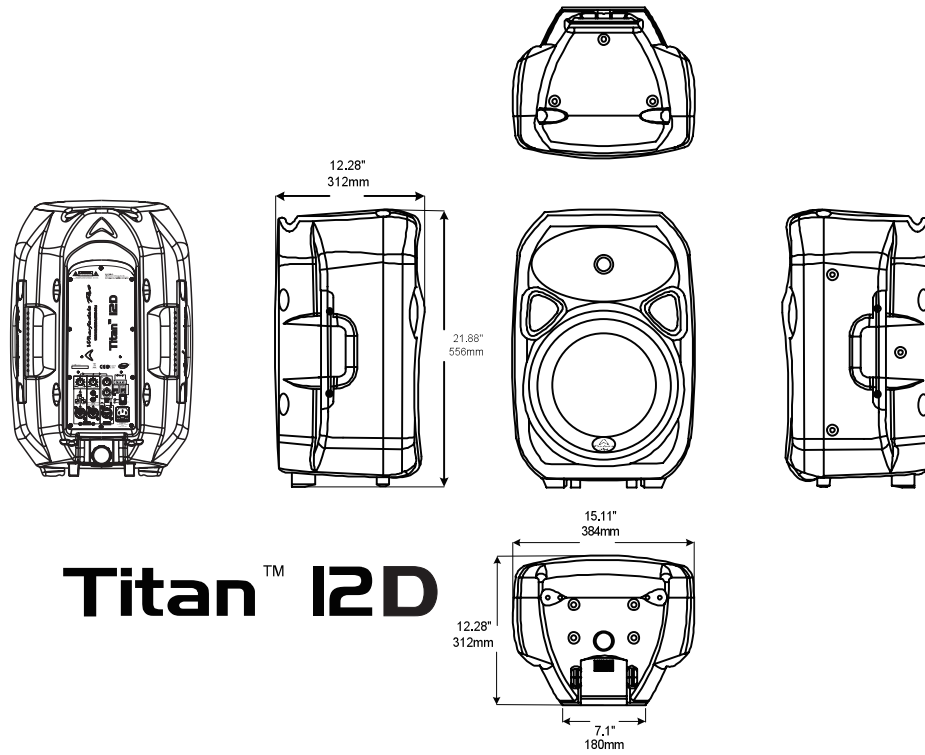



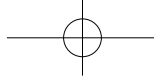

# DIMENSIONS

## Titan™ SUB A12

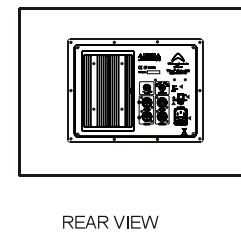
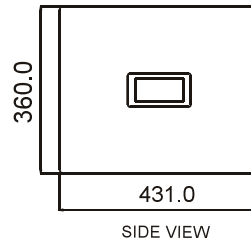
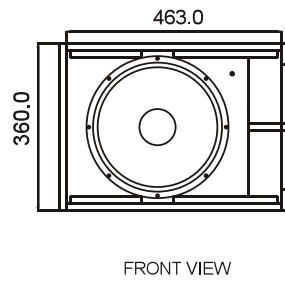
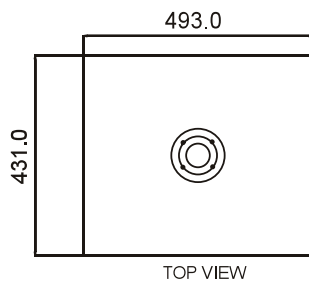

## Titan™ SUB 15A MKII

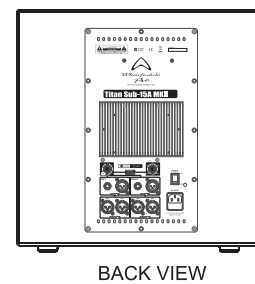
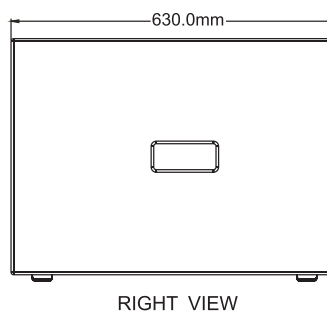
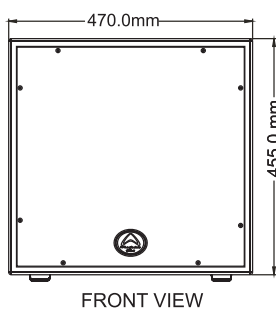
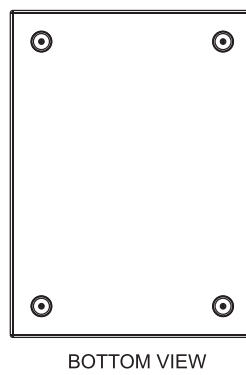
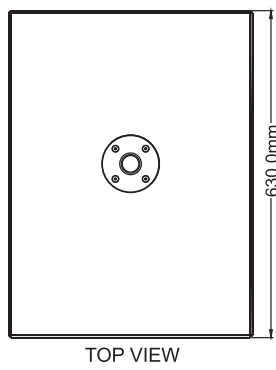

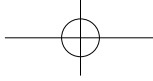

## **OPERATING MANUAL AND USER GUIDE**

---

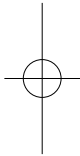
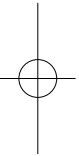

### **WHARFEDALE PRO LIMITED WARRANTY**

Wharfedale Pro products are warranted of manufacturing or material defects for a period of one year from the original date of purchase. In the event of malfunction, contact your authorized Wharfedale Pro dealer or distributor for information.

\*Be aware that warranty details may differ from country to country. Contact your dealers or distributor for information. These terms do not infringe your statutory rights.

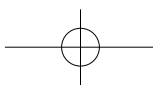

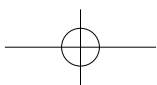
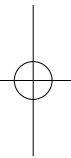
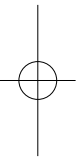
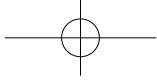

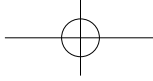

Wharfedale Professional  
IAG House 13/14 Glebe Road Huntingdon Cambridgeshire PE29 7DL, England

[www.wharfedalepro.com](http://www.wharfedalepro.com)

Wharfedale Professional reserves the right to alter or improve specifications without notice.  
All rights reserved © 2013 Wharfedale Pro. Wharfedale Pro is a member of the International Audio Group (IAG).

