

Статичная камера CleverMic FC1201 (SDI, HDMI, LAN)

User Manual

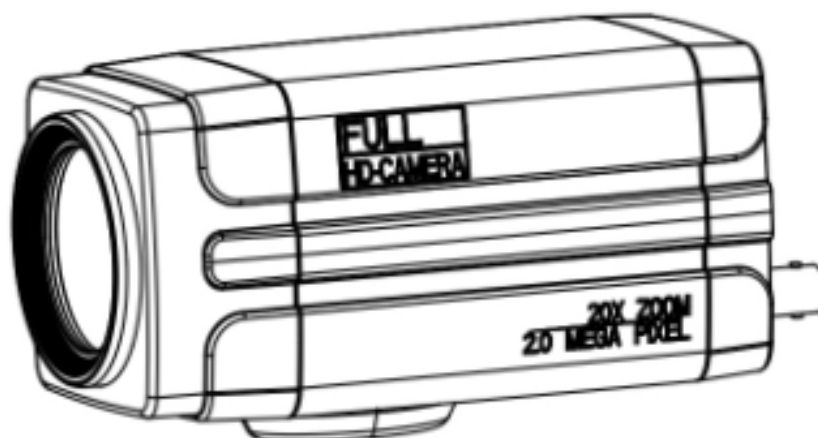

Preface:

Thanks for using our HD color video conference camera.

This manual introduces the function installation and operation of the HD camera. Prior to installation and usage, please read the manual thoroughly.

Warning

This product can be only used in specified range in order to avoid any damage or danger;

- Don't expose the camera to rain or moisture place
- Don't remove the cover to reduce the risk of electric shock. Refer servicing to qualified personnel.
- Never operate the camera under unqualified temperature , humidity and power supply;
- Please use the soft cloth to clean the camera. Use neuter cleanser if bad smeared .Don't use the strong or cleanser avoiding scuffing.

Electric Safety

Installation and operation must accord with electric safety standard

Caution to transport

Avoid stress,vibration and soakage in transport,storage and installation.

Polarity of power supply

The power supply of the product is $\pm 12V$.,polarity of the power supply drawing pic 0.1.

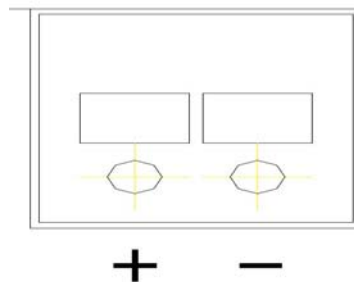

Pic 0.4.1 Power plug

Careful of installation

This series item must put on the smooth desk or platform,and it can not be installed slant ways;

Don't apply in corrosive liquid,gas or solid environment to avoid the cover which is made up of organic material.

Never power on before installation is completed.

Don't disassemble discretionarily.

We are not responsible for any unauthorized modification or dismantling.

Attention

Electromagnetic filed under certain rate may affect camera image!

Content

1、 Fast Installation.....	4
1.1、 CAMERA INTERFACE EXPLANATION.....	4
1.2、 POWER ON SELF-TEST.....	5
1.3、 VIDEO OUTPUT.....	5
1.4、 BRACKET MOUNTING.....	6
2、 Product overview.....	7
2.1、 PRODUCT INTRODUCTION.....	7
2.1、 <i>Dimension</i>	7
2.2、 MAIN FEATURES.....	8
2.2.1、 <i>Camera performance</i>	8
2.2.2、 <i>Network performance</i>	8
2.2.3、 <i>Technical specification</i>	8
2.2.4、 <i>Keyboard Introduction</i>	10
3、 Application Instruction.....	10
3.1、 VIDEO OUTPUT.....	10
3.1.1、 <i>Power-On Initial Configuration</i>	10
3.1.2、 <i>Video output</i>	11
3.2、 MENU SETTING.....	11
3.2.1、 <i>Main menu</i>	11
3.2.2、 <i>System setting</i>	12
3.2.2、 <i>Camera setting</i>	12
3.2.3、 <i>ZOOM</i>	16
3.2.4、 <i>Video Format</i>	16
3.2.5、 <i>VERSION</i>	17
3.2.6、 <i>RESTORE DEFAULT</i>	17
4、 Network Connection.....	18
4.1、 CONNECTING MODE.....	18
4.2、 IE LOG IN.....	21
4.2.1、 <i>Web client</i>	21
4.2.2、 <i>Preview</i>	22
4.2.3、 <i>Playback</i>	22
4.2.4、 <i>Configuration</i>	23
4.2.5、 <i>Video configuration</i>	23
4.2.6、 <i>Network configuration</i>	25
4.2.7、 <i>System configuration</i>	26
4.2.8、 <i>Logout</i>	27
5、 Serial communication control.....	27
5.1、 VISCA PROTOCOL LIST.....	27
5.1.1、 <i>Camera return command (Correct)</i>	27
5.1.2、 <i>Camera control command</i>	28
5.1.3、 <i>Inquiry command</i>	31

5.2、 PELCO-D PROTOCOL COMMAND LIST.....	33
5.3、 PELCO-P PROTOCOL COMMAND LIS.....	33
6、 Camera Maintenance and Troubleshooting.....	35
6.1、 CAMERA MAINTENANCE.....	35
6.2、 TROUBLESHOOTING.....	35

1、 Fast Installation

1.1、 Camera Interface Explanation

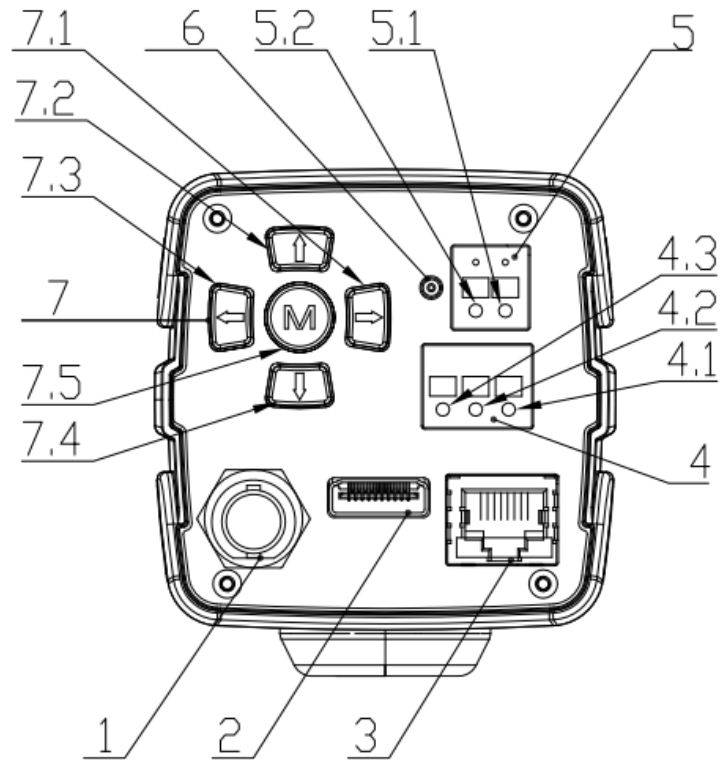

Pic 1.1 Back plate

1. HD-SDI interface
2. HDMI interface
3. LAN interface
4. RS485 interface, support VISCA 、 PELCO-D 、 PELCO-P protocol
 - 4.1 RS485 D-
 - 4.2 RS485 D+
 - 4.3 RS485 GND
5. Power interface, DC+12V, notes for polarity
 - 5.1 DC+12V negative
 - 5.2 DC+12V positive
6. Power indicator
7. Keyboard
 - 7.1 Zoom In/Right
 - 7.2 Focus -/Down
 - 7.3 Zoom Out/Left
 - 7.4 Focus +/Up
 - 7.5 Menu/Confirm

1.2、 Power on self-test

1)Power on: connect DC12V power supply adapter, and the indicator light will be on.

2)Self-testing: Power on with power indicator light on ,camera module will stretches. When the module finish stretches, the self-testing is finished.

Note: If you set parking position,when Power on self-test is completed,the camera automatically go to the parking position.

1.3、 Video output

1) video output from LAN:

- a) Network cable connection port:
- b) Web page Login: : open your browser and enter 192.168.5.163 in the address bar (factory default); press Enter to enter into the login page; click on the "player is not installed,please download and install!" and follow the installation steps for installation. Then enter the user name *admin* and password *admin* (factory default); press Enter to enter into the preview page,users can carry out PTZ control,video recording,playback,configuration and other operations.
- c) If without image, refer to Chapter 6 Trouble Shooting



Pic 1.3.1 Web login page

2) 3G-SDI video output:

- a) 3G-SDI video cable connection
- b) Connect the camera and the monitor via 3G-SDI video cable; video output is available after camera self-test.
- c) If without image, refer to Chapter 6 Trouble Shooting

3) HDMI video output :

- a) HDMI video cable connection
- b) Connect the camera and the monitor via HDMI video cable; video output is available after camera self-test
- c) If without image, refer to Chapter 6 Trouble Shooting

1.4、 BRACKET MOUNTING

Note: The materials of the wall must be follow board or concrete to mount the camera on the wall or ceiling, while plasterboard is not usable.

1) Bracket installation steps

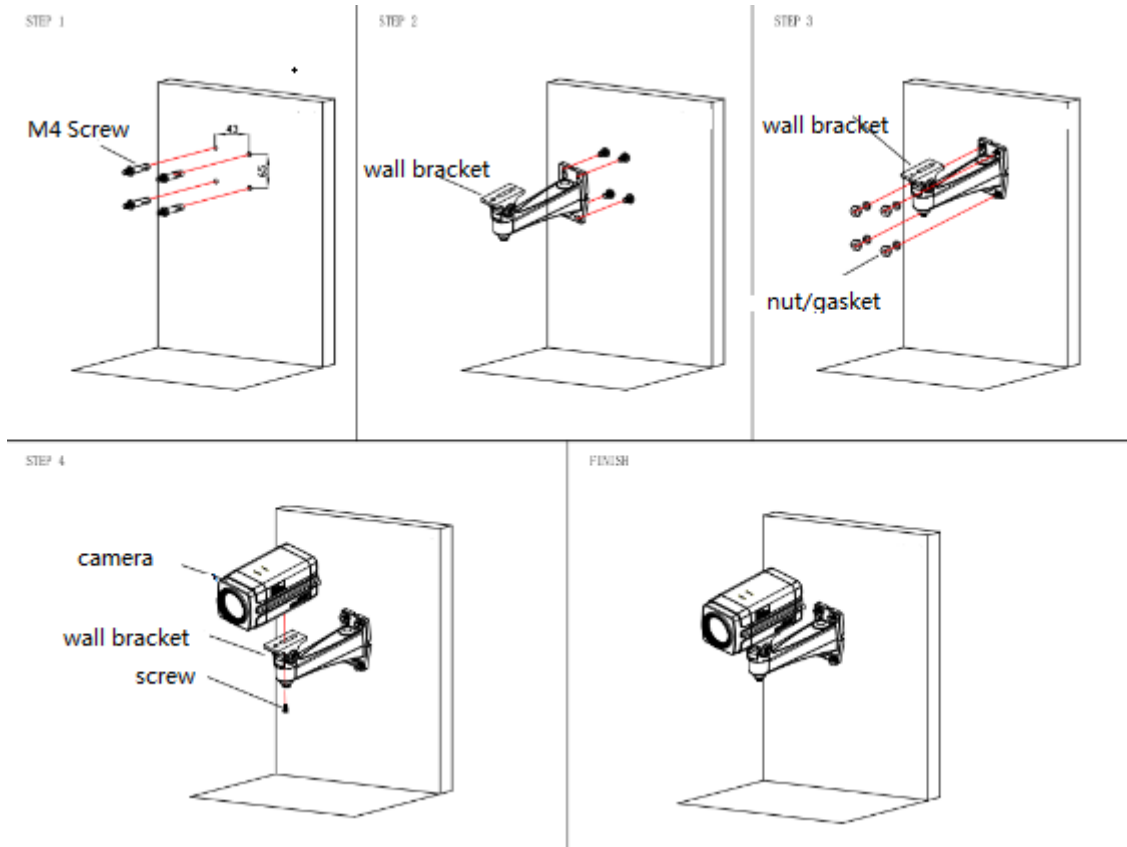

2) Accessories introduction

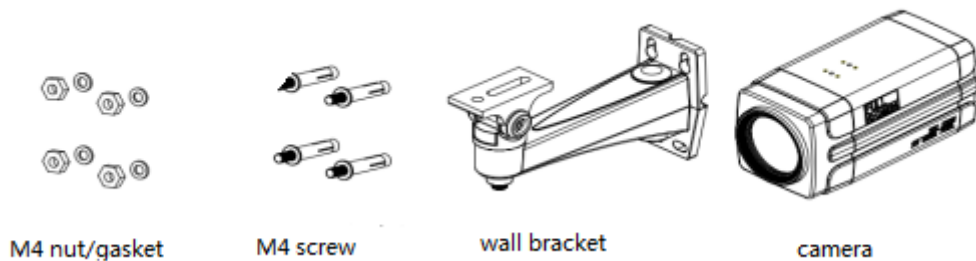

Note: Mounting brackets as shown, can be only installed and maintained by a qualified technician. The product installation must strictly comply with all local electrical safety standards and may not be installed beyond the limited temperature, humidity

2、 Product overview

2.1、 Dimension

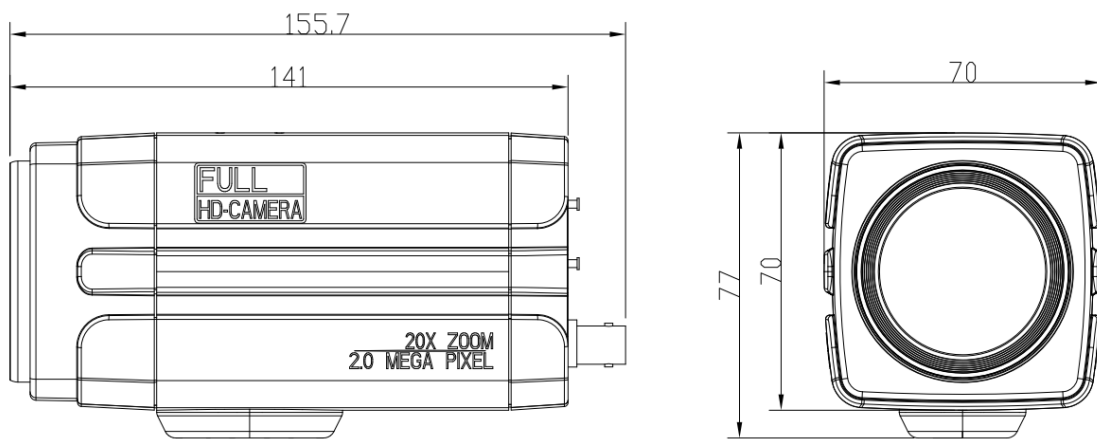

Pic 2.1. Camera dimension

2.2、 Main Features

2.2.1、 Camera performance

This series camera offers perfect functions,superior performance and rich interfaces. The features include advanced ISP processing algorithms to provide vivid images with a strong sense of depth,high resolution and fantastic color rendition. It supports H.264/H.264+ encoding which makes motion video fluent and clear even with less than ideal bandwidth conditions.

- 1.**Superb high-definition image:** It employs 1/2.8 inch high quality CMOS sensor. Resolution is up to 1920x1080 with frame rate up to 60 fps.
- 2.**Various optical zoom lens:** It has 20X optical zoom lens for options,3.3degree~54.7degree,2.9degree~55.4degree lens for option..
3. **Leading Auto focus technology:** Leading auto focus algorithm makes lens a fast,accurate and stable auto-focusing.
4. **Low noise and High SNR:** Low Noise CMOS effectively ensure high SNR of camera video.
Advanced 2D/3D noise reduction technology is also used to further reduce the noise,while ensuring image sharpness.
- 5.**Multi-Format Video Outputs:** support HDMI,3G SDI,wired LAN, the 3G-SDI is available for 100m transmission at 1080p60 format.
- 6.**Support Multiple Control Protocol:** Support VISCA,PELCO-D,PELCO-P protocols which can also be automatically recognized. Support VISCA control protocol through IP port.
- 7.Keyboard: There are up/down/left/right/confirm control key in the back part of the cameras
- 8.Control Interface: Support RS485, Wired LAN, convenient for remote control after installation
- 9.Support parking position preset: Camera will run to the parking position after power on(can choose on/off on menu)
- 10.**Wide application:**tele-education,lecture capture, Webcasting,Videoconferencing, Tele-training, Tele-medicine, Interrogation and Emergency command systems.

2.2.2、 Network performance

1. **Multiple Video compression:** Support H.264/H.264+ video compression; Support compression of resolution up to 1920x1080 with frame up to 60 fps.
2. **Multiple network protocol:** Support ONVIF,RTSP,RTMP protocols and RTMP push mode,easy to link streaming media server (Wowza,FMS)

2.2.3、 Technical specification

Model	
Camera Parameter	
Sensor	1/2.8 inch high quality HD CMOS sensor
Effective Pixels	2.07 million、16: 9
Video Format	1080P60/50/30/25/59.94/29.97 /59.94/29.97
Optical Zoom	20x Optical Zoom

	f=4.7~94mm
View Angle	2.9° (tele) ~55.4° (wide)
Aperture	F1.6 ~ F3.5
Digital Zoom	X10
Minimum Illumination	0.5Lux(F1.8, AGC ON)
DNR	2D & 3D DNR
White Balance	Auto / Manual/ One Push/ 3000K/ 4000K/5000K/6500K
Focus	Auto/Manual
Iris	Auto/Manual
Electronic Shutter	Auto/Manual
BLC	ON/OFF
WDR	OFF/ Dynamic level adjustment
Video Adjustment	Brightness, Color, Saturation, Contrast, Sharpness, B/W mode, Gamma curve
SNR	>55dB
Input/Output Interface	
Video Interfaces	HDMI、 3G-SDI
Image Code Stream	Dual stream output
Video Compression Format	H. 265、 H. 264
Control Protocol	VISCA/Pelco-D/Pelco-P; Baud Rate: 115200/9600/4800/2400bps
IP Interface	100M IP port (100BASE-TX); Support Visca protocol control through IP port.
Network Protocol	RTSP、 RTMP、 ONVIF、 GB/T28181
Power Interface	(DC12V)
Other Parameter	
Supply Adapter	Input AC110V-AC220V, output DC12V/1A
Input Voltage	DC12V±10%
Input Current	400mA (Max)
Consumption	4.8W(Max)
Store Temperature	-10℃~+60℃
Store Humidity	20%~95%
Working Temperature	-10℃~+50℃
Working Humidity	20%~80%
Dimension	155.7mmX70mmX70mm
Weight	0.7kg
Working Environment	Indoor
Remote Operation (IP)	Remote Upgrade, Reboot and Reset
Accessory	12V/1A power supply, manual, warranty card, installation bracket (option)

2.2.4、 Keyboard Introduction

- **Menu**

Menu、 Confirm share the same key“menu/ok” ;
when change the menu parameter,press menu/ok to confirm

- **Up**

In the menu screen, when the cursor is on a particular sub-menu, the cursor will move up to the selected menu when we press the "up"key.

When it is not on menu screen, it is used as Focus+

- **Down**

In the menu screen, when the cursor is on a particular sub-menu, the cursor will move up to the selected menu when we press the "down"key.

When it is not on menu screen, it is used as Focus-

- **Left**

In the menu screen, when the cursor is on a particular sub-menu, we can go to the selected menu by pressing the “left” key.

When it is not on menu screen, it is used as Zoom out.

- **Right**

In the menu screen, when the cursor is on a particular sub-menu, we can go to the selected menu by pressing the “Right” key.

When it is not on menu screen, it is used as Zoom In.

3、 Application Instruction

3.1、 Video Output

3.1.1、 Power-On Initial Configuration

Connecting the power,camera will have initial configuration,lens will finish zoom in/out,the auto-testing is finished. If the preset 0 is set,camera will go to the 0 preset position after initial configuration.

3.1.2、 Video output

Connect to the video output cable: the user select the output mode according to the machine model.

1. network output: connect this product and your computer through network cable,then open the browser,enter the camera IP address (factory default 192.168.5.163) in the address bar,then to the login page and input a user name and password (factory default are "admin") ,Finally enter the preview page,and the image comes out. (Note: If you forget your user name,password,IP address,you can manually restore the default by the default setting option in the menu.
2. 3G-SDI output or HDMI)output: Connect the monitor with the corresponding video output interface,then the monitor output image.

3.2、 MENU SETTING

3.2.1、 Main menu

In normal working mode,press **【MENU】** key to display the menu,using scroll arrow to point at or highlight the selected items.

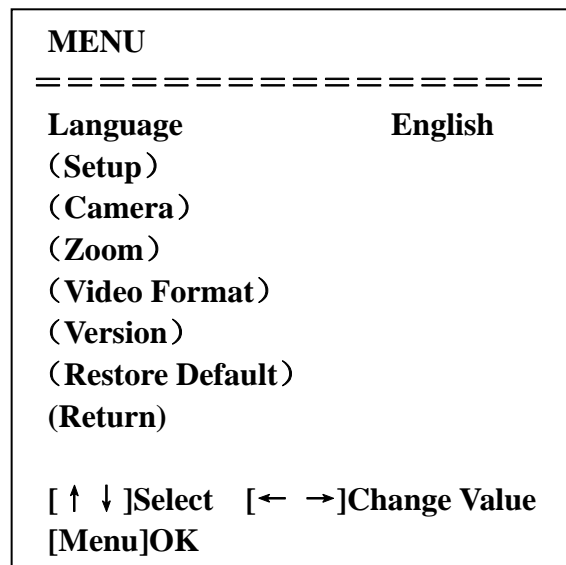

LANGUAGE: Language setting,Chinese / English

SETUP:System setting

CAMERA OPTION:Camera setting

LEN OPTION: Len setting

VERSON: camera version setting

Restore Default:Reset setting

[↑↓] Select: for selecting menu

[← →] Change value: for modify parameters

[MENU] OK:Press [MENU] to confirm

3.2.2、 System setting

Move the pointer to the (Setup) in the Main Menu,click the 【MENU】 key and enter into the (System Setting) as shown below,

SETUP	
=====	
Protocol	Auto
Visca Address	1
Visca Address Fix	OFF
PELCO-P Address	1
PELCO-D Address	0
Baudrate	9600
Return	
[↑ ↓]Select [← →]Change Value	
[Menu]OK	

PROTOCOL:VISCA/Pelco-P/Pelco-D/Auto

Visca ADDR:VISCA=1~7 Pelco-P=1~16(1~16)/Pelco-D = 0~15(0~15)

Baud rate: 2400/4800/9600/115200

RETURN: Return to the former menu(if it is main menu, means close menu)

[↑↓] Select: for selecting menu

[← →] Change value: for modify parameters

[MENU] OK:Press [MENU] to confirm

3.2.2、 Camera setting

Move the pointer to the (CAMERA) in the Main Menu,click the 【MENU】 key and enter the (CAMERA) as follow,

CAMERA	
=====	
(Exposure)	
(Color)	
(Image)	
(Focus)	
(Noise Reduction)	
Return	
[↑ ↓]Select [← →]Change Value	
[Menu]OK	

EXPOSURE:Enter into Exposure setting

COLOR: Enter into color setting

Image: Enter into image setting

Focus: Enter into focus setting

Noise Reduction: Enter into noise reduction

RETURN: Return to the former menu(if it is main menu, means close menu)

[↑↓] **Select:** for selecting menu

[← →] **Change value:** for modify parameters

[MENU] **OK:**Press [MENU] to confirm

1) EXPOSURE SETTING

Move the pointer to the (EXPOSURE) in the Main Menu,click the **【MENU】** and enter the (EXPOSURE SET) as follow,

EXPOSURE	
=====	
Mode	Auto
EV	OFF
BLC	OFF
Flicker	50Hz
G.Limit	3
WDR	5
Return	
[↑ ↓]Select [← →]Change Value	
[Menu]OK	

MODE : Auto,Manual,Shutter priority,Iris priority and Brightness priority.

EV : On/Off (only available in auto mode)

Compensation level: -7~7 (only available in auto mode when EV is ON)

BLC: ON/OFF for options (only available in auto mode)

Anti-Flicker: OFF/50Hz/60Hz for options (only available in Auto/Iris **priority**/Brightness **priority** modes)

Gain limit: 0~15(only available in Auto/ Iris **priority** /Brightness **priority** mode)

WDR: Off,1~8

Shutter priority:1/25,1/30,1/50,1/60,1/90,1/100,1/120,1/180,1/250,1/350,1/500,1/1000,1/2000,1/3000,1/4000,1/6000,1/10000(only available in Manual and Shutter priority mode)

IRIS priority:OFF,F11.0,F9.6,F8.0,F6.8,F5.6,F4.8,F4.0,F3.4,F2.8,F2.4,F2.0,F1.8(only available in Manual and Iris priority mode)

BRIGHTNESS: 0~23 (only available in Brightness **priority** mode)

RETURN: Return to the former menu(if it is main menu, means close menu)

[↑↓] **Select:** for selecting menu

[← →] **Change value:** for modify parameters

[MENU] **OK:**Press [MENU] to confirm

2) COLOR SETTING

Move the pointer to the (COLOR) in the Main Menu,click the **【MENU】** and enter the (COLOR SET) as follow,

COLOR	
=====	
WB Mode	Auto
Saturation	80%
Hue	7
AWB Sensitivity	High
Color style	Default
Color temp	Low
Return	
[↑ ↓]Select [← →]Change Value	
[Menu]OK	

WB MODE:Auto,3000K,4000K,5000K,6500K,Manual,One Push

RED GAIN: 0~255(only available in Manual mode)

BLUE GAIN: 0~255(only available in Manual mode)

SATURATION: 60%,70%,80%,90%,100%,110%,120%,130%

Hue: 0~14

AWB Sensitivity: high/middle/low

Color Style: Default,style1~4.

Color temp: high/middle/low

RETURN: Return to the former menu(if it is main menu, means close menu)

[↑↓] **Select:** for selecting menu

[← →] **Change value:** for modify parameters

[MENU] **OK:**Press [MENU] to confirm

3) IMAGE

Move the pointer to the (IMAGE) in the Menu,click the **【HOME】** and enter the (IMAGE) as follow,

IMAGE	
=====	
Brightness	6
Contrast	8
Sharpness	2
Flip-H	OFF
Flip-V	OFF
B&W-Mode	Color
Gamma	Default
DZoom	OFF
DCI	Close
Return	
[↑ ↓]Select [← →]Change Value	
[Menu]OK	

Brightness: 0~14
Contrast: 0~14
Sharpness:0~15
Flip-H: On/Off
Flip-V: On/Off
B&W mode:color,black/white
Gamma:default,0.47,0.50,0.52,0.55
DZoom:digital zoom options: On/Off
DCI:Dynamic Contrast: Off,1~8

RETURN: Return to the former menu(if it is main menu, means close menu)

[↑↓] Select: for selecting menu
[← →] Change value: for modify parameters
[MENU] OK:Press [MENU] to confirm

4) FOCUS

Move the pointer to the (FOCUS) in the Menu,click the **[MENU]** and enter the (FOCUS) as follow,

FOCUS	
=====	
Focus Mode	Auto
AF-Zone	Center
AF-Sensitivity	Low
Return	
[↑ ↓]Select [← →]Change Value	
[Menu]OK	

Focus mode:Auto,manual
AF-Zone:Up,middle,down
AF-Sensitivity:High,middle,low

RETURN: Return to the former menu(if it is main menu, means close menu)

[↑↓] Select: for selecting menu
[← →] Change value: for modify parameters
[MENU] OK:Press [MENU] to confirm

5) NOISE REDUCTION

Move the pointer to the (NOISE REDUCTION) in the Menu,click the **[MENU]** and enter the (NOISE REDUCTION) as follow,

NOISE REDUCTION	
=====	
NR-2D	Auto
NR-3D	5
Dynamic Hot Pixel	OFF
Return	
[↑ ↓]Select [← →]Change Value	
[Menu]OK	

2D NOISE REDUCTION: Auto,close,1~7
3D NOISE REDUCTION: Close,1~8
Dynamic Hot Pixel: Close,1~5

RETURN: Return to the former menu(if it is main menu, means close menu)

[↑↓] Select: for selecting menu
[← →] Change value: for modify parameters
[MENU] OK:Press [MENU] to confirm

3.2.3、 ZOOM

Move the pointer to the (ZOOM) in the Main Menu,click the **【MENU】** and enter the (ZOOM) as follow,

Zoom	
=====	
Zoom speed	8
Park Set	ON
Saving Park?	NO
Return	
[↑ ↓]Select [← →]Change Value	
[Menu]OK	

Zoom speed:Set the zoom speed for remote controller,1~8

Park Set: ON/OFF

Saving Park: YES/NO

RETURN: Return to the former menu(if it is main menu, means close menu)

[↑↓] **Select:** for selecting menu

[← →] **Change value:** for modify parameters

[MENU] OK:Press [MENU] to confirm

3.2.4、 Video Format

Move the pointer to the (**Video Format**) in the Menu,click the **【MENU】** and enter the (**Video Format**) as follow,

VIDEO FORMAT	
=====	
1080P60	1080P50
1080I60	1080I50
1080P30	1080P25
720P60	720P50
720P30	720P25
1080P59.94	
1080I59.94	
1080P29.97	
720P59.94	
720P29.97	
Return	

Note: Only in the model S-S20/T20,,the video format is displayed in the menu item.(M version does not support format above 30fps)

3.2.5、 VERSION

Move the pointer to the (VERSION) in the Main Menu,click the **【MENU】** and enter the (VERSION) as follow,

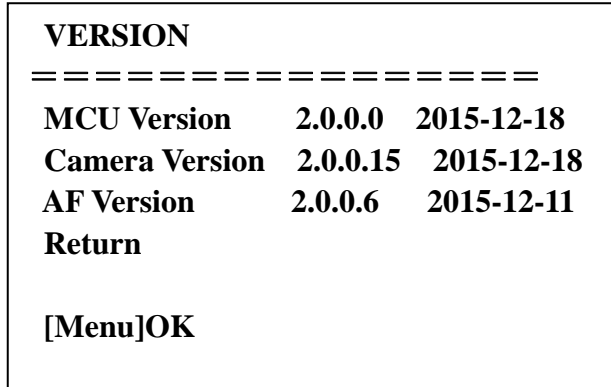

MCU Version:Display MCU version information
Camera Version: Display camera version information
AF Version:Display the focus version information

RETURN: Return to the former menu(if it is main menu, means close menu)

[↑↓] Select: for selecting menu
[← →] Change value: for modify parameters
[MENU] OK:Press [MENU] to confirm

3.2.6、 RESTORE DEFAULT

Move the pointer to the (RESTORE DEFAULT) in the Main Menu,click the **【MENU】** and enter the (RESTORE DEFAULT) as follow,

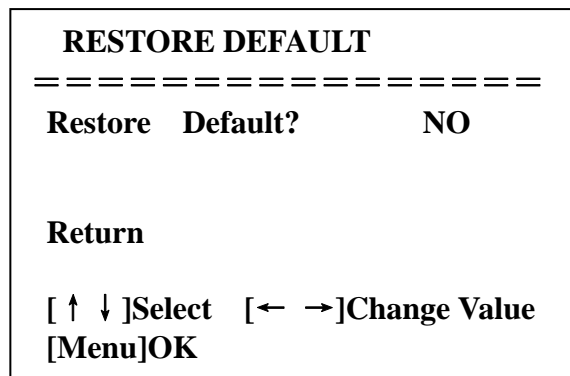

Restore default: options:yes/no

RETURN: Return to the former menu(if it is main menu, means close menu)

[↑↓] Select: for selecting menu
[← →] Change value: for modify parameters
[MENU] OK:Press [MENU] to confirm

4、 Network Connection

4.1、 Connecting Mode

- 1) **Direct connection:** Connect the camera and computer by network connecting cable.
- 2) **Internet connection mode:** Connect the camera to Internet by Router or Switch and user can log in the device by browser.

Note: Please do not put the power and network cable in places where can be easily touched to prevent video quality lowered by unstable signal transmission due to poor contact of cables.

The computer must have the network segment where the camera IP address belong to. The device will not be accessible if without the segment. I.E. The camera default IP address is 192.168.5.163,then segment 5 must be added in the computer. Specific steps are as below:

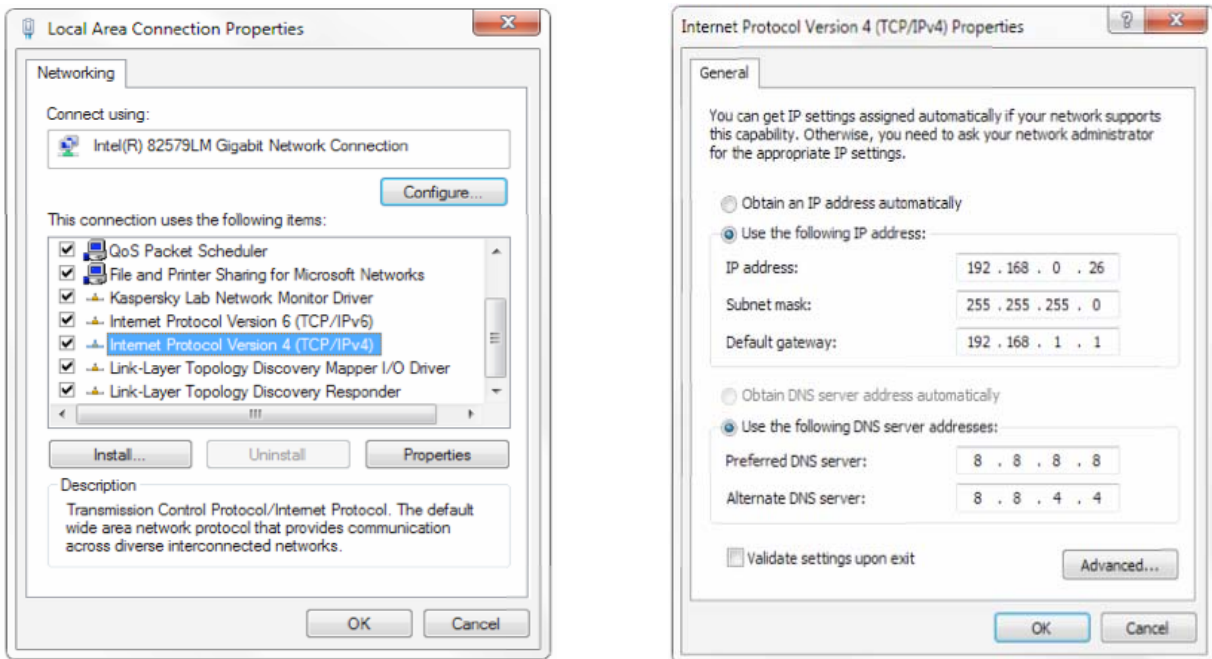

Pic 4.1.1 Local Network Setting

- a) Firstly open the window of Local Area Connection Properties on computer,select the “Internet protocol version 4(TCP/IPv4)” as shown by pic 4.1 .
- b) Double click or click the property “Internet” protocol version 4 (TCP/IPv4)to enter into the Internet Protocol Version 4(TCP/IPv4) Properties window,and select “Advanced” option as shown Pic 4.1.1
- c)select “Advanced” to enter into the Advanced TCP/IP Setting and add IP and subnet mask in the IP browser as picture 4.1.2,Click the “Confirm” to finish the adding of IP segment. User can add the corresponding network segment according to the revised IP address of the camera.

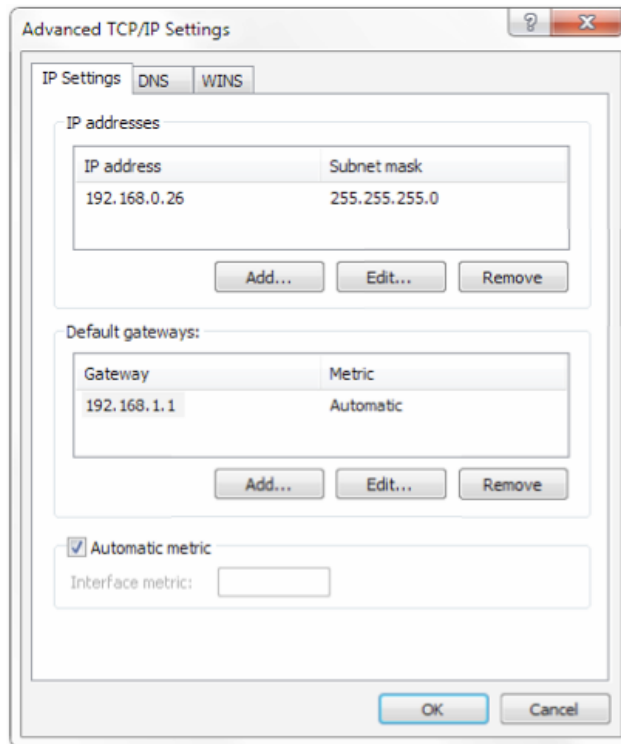

Pic 4.1.2 Network Advanced Setting

Click the “Start” and select “Operation” to input cmd as picture 4.1.3 to verify if the network segment has been successfully added.

c)

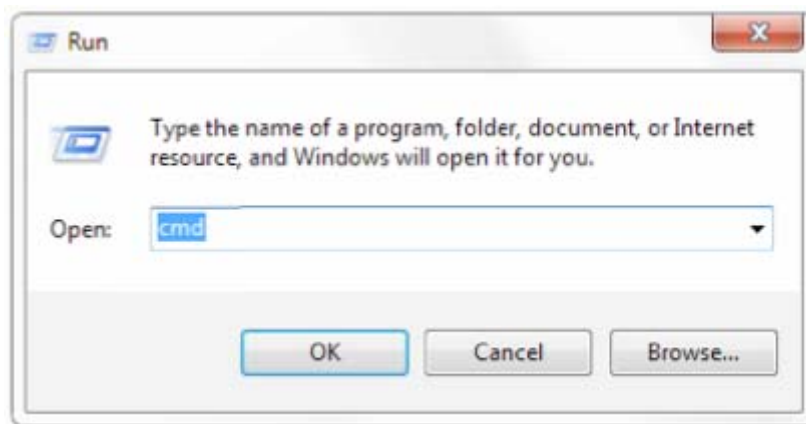

Pic 4.1.3 Run Window

Click “OK” and open the DOS command window, input ping 192.168.5.26 and press Enter key, it will show message as below: which means network segment adding is succeed.

d)

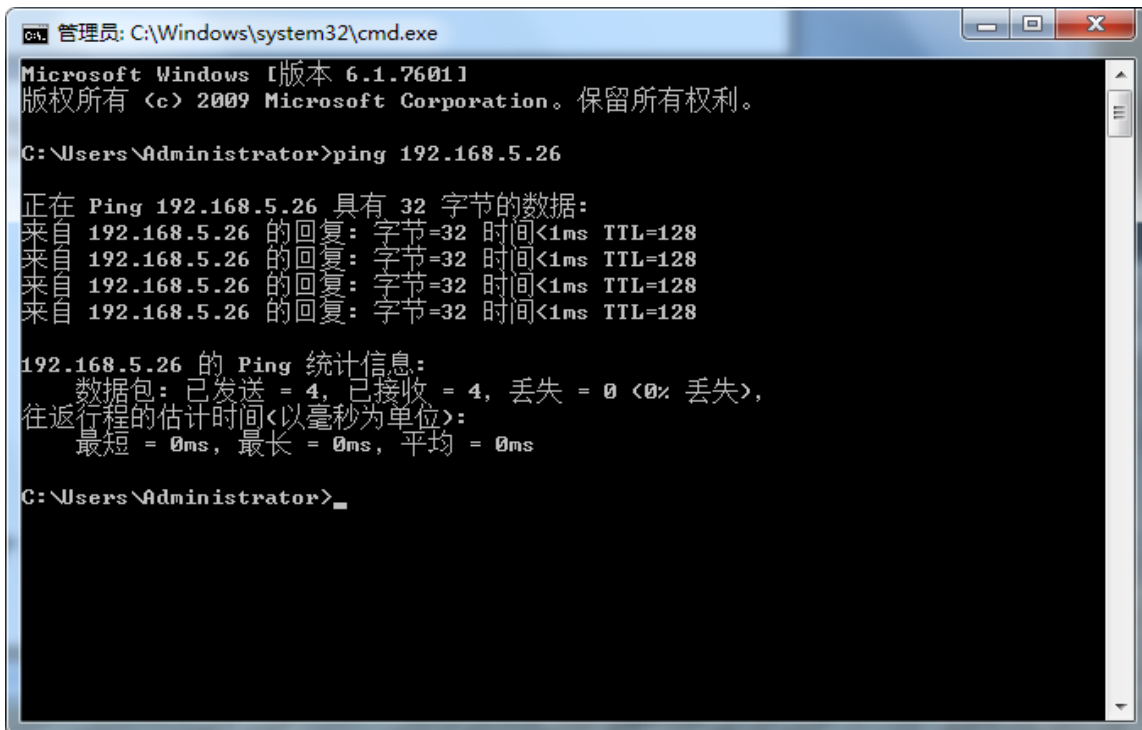

```
C:\Windows\system32\cmd.exe
Microsoft Windows [版本 6.1.7601]
版权所有 (c) 2009 Microsoft Corporation。保留所有权利。

C:\Users\Administrator>ping 192.168.5.26

正在 Ping 192.168.5.26 具有 32 字节的数据:
来自 192.168.5.26 的回复: 字节=32 时间<1ms TTL=128
来自 192.168.5.26 的回复: 字节=32 时间<1ms TTL=128
来自 192.168.5.26 的回复: 字节=32 时间<1ms TTL=128
来自 192.168.5.26 的回复: 字节=32 时间<1ms TTL=128

192.168.5.26 的 Ping 统计信息:
    数据包: 已发送 = 4, 已接收 = 4, 丢失 = 0 (0% 丢失),
往返行程的估计时间<以毫秒为单位>:
    最短 = 0ms, 最长 = 0ms, 平均 = 0ms

C:\Users\Administrator>
```

Pic 4.1.4 DOS control platform

User can also to verify network connection as steps above mentioned after the finish of camera self-check. If IP is default,open DOS command window and input 192.168.5.163,then press Enter key,it will show message as pic 4.1.5: which means network connection is normal.

e)

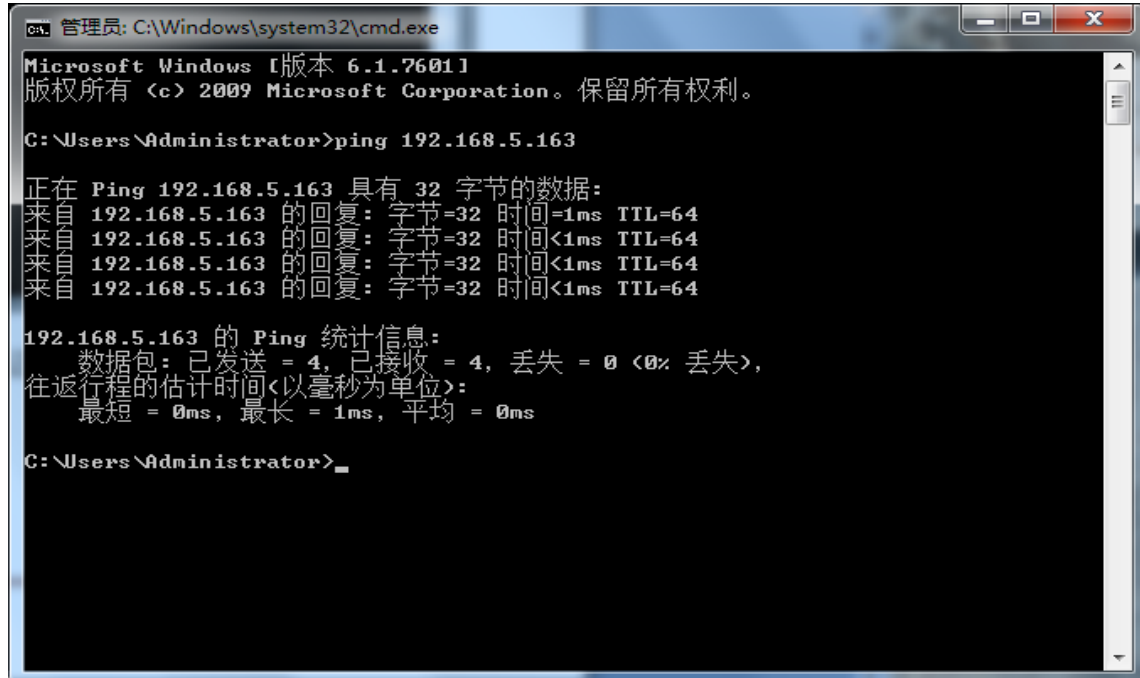

```
C:\Windows\system32\cmd.exe
Microsoft Windows [版本 6.1.7601]
版权所有 (c) 2009 Microsoft Corporation。保留所有权利。

C:\Users\Administrator>ping 192.168.5.163

正在 Ping 192.168.5.163 具有 32 字节的数据:
来自 192.168.5.163 的回复: 字节=32 时间=1ms TTL=64
来自 192.168.5.163 的回复: 字节=32 时间<1ms TTL=64
来自 192.168.5.163 的回复: 字节=32 时间<1ms TTL=64
来自 192.168.5.163 的回复: 字节=32 时间<1ms TTL=64

192.168.5.163 的 Ping 统计信息:
    数据包: 已发送 = 4, 已接收 = 4, 丢失 = 0 (0% 丢失),
往返行程的估计时间<以毫秒为单位>:
    最短 = 0ms, 最长 = 1ms, 平均 = 0ms

C:\Users\Administrator>
```

Pic 4.1.5 ping connecting result display

4.2、 IE Log In

4.2.1、 Web client

1) Web client

Input the IP address 192.168.5.163 of the device in the address filed of browser and click Enter button to enter into Web Client login page as pic 4.2.2.



Pic 4.2.2 Network log in

Note: Web access supported browsers: IE,Chrome,Firefox,Safari, but web plug-in can only support IE browser. 360 browser and other conventional browser.

2) Download/Install Plug in

When first using IE browser to access the web conferencing camera,the login page will appear "Playback plug-in is not installed,please download and install!". Click on this message,download and install MRWebXinstall.exe,according to information prompts.



Pic. 4.2.3 Install Plug-in

Note:Currently Web plug in only supported by the IE browser.

Input the user name and password after plug in installed, click to login (the default user name and password are both “admin” and user can change them after logging in) and enter into Web client management interface as below

4.2.2、 Preview

After login in the management interface it will show the default video preview interface as below picture. User can control the zoom, focus, record, snapshot, enlarge, full screen and position 0 preset set operations etc.

1) Login in as administrator

2) Login in as normal user

4.2.3、 Playback

1) Playback the recording file: Click “Playback” to enter the page of recording file and picture file playback. Firstly record, snapshot and save the file when previewing, then select “recording file” and click the search as below to playback the recording file.

2) Select file type “picture file” and click the search as below to playback the picture file.

4.2.4、 Configuration

Click **Configuration** to enter into the device parameters setting page.

Major options: Local configure, Audio configure, Video configure, Network configure, Platform access configure and System configure. The detailed description refer to below sheet.

Menu	Explanation
Local configure	Including video preview mode, record video packing time, record video storage route settings etc.
Audio configure	Including audio compressing format, sampling frequency, sampling precision, compressing code rate settings etc.
Video configure	Including video encoding, video parameters, character-overlapping, character size, video output setting etc.
Network configure	Including basic parameters, Ethernet, DNS, wireless network setting etc.
Pan Tilt configure	Including basic parameters, system parameters setting etc.
Platform access configure	Including ONVIF docking switch
System configure	Including equipment property, system time, user management, version update, Reset, Reboot device settings etc.

1)Local configure

a) Video Preview Mode:user can choose real-time priority or fluency priority:The delay will be small when under real time priority mode and fluency will be good when under fluency priority mode. Setting based on the user need(Default value: real time normal (2), real time best (1), fluency normal (3), fluency good (4) and fluency best (5))

b)Recording video packing time(minute): Set recording video packing time (default is 10, range from 1~120 minutes)

c)Recording/Snapshot file storage route: Set local recording video/snapshot file storage route.(Default D:\MyIPCam\)

d) Click the **Save** button to make settings effective.

2)Audio Configuration

a) Switch: Choose to enable the audio or not.

b) Compressing format: Set audio compressing format and the device will reboot automatically after change (default MP3,PCM,AAC optional)

c) Sampling frequency: Set sampling frequency and the device will reboot automatically after change (default 44100,16000,32000 and 48000 optional)

d) Sampling precision: Set sampling precision (default 16bits)

e) Compressing code rate: Set audio compressing code rate (default 64bits, 32,48,96,128bits optional)

f) Click "Save" button and the settings become effective when noting "Saved successfully"

Note: This function were not supported currently.

4.2.5、 Video configuration

1) Video encoding

a) Code stream:It will call different code stream when setting different video output format. (Main stream and Secondary stream)

- b) Compressing format:** Set video compressing format and the device will reboot automatically (Main/Second code stream default H.264, H.265 optional)
- c) Video size:** set resolution, then device will restart automatically (Main stream default 1920*1080, 1280*720 optional, Secondary stream default 640 * 320, 320 * 180, 1280 * 720 , 1920*1080 optional).
- d) Stream Rate control:** Set rate control mode, then device will restart automatically (Primary / secondary stream default variable bit rate, fixed rate is for option).
- e) Image quality:** Set image quality (default for Primary stream is better image, secondary stream default is bad image. Best, better, good, bad, worse, worst for optional).
- f) Rate (Kb / s):** Set the video bit rate (main stream default 4096Kb / s, 64-12288Kb / s optional; secondary stream default 1024Kb / s, 64-10240Kb / s optional).
- g) Frame rate (F / S):** Set the video frame rate (primary / secondary stream default 25F / S, primary stream 5-30F/S optional, secondary stream 5-30F / S optional).
- h) Keyframe interval:** Set the key frame interval (primary / secondary stream default 75F, primary / stream 1-300F optional. secondary stream 1-150F optional).
- i) Name of Stream:** User can revise the name of stream when obtaining rtsp or rtmp stream; main stream (default live/av0), secondary stream (default live/av1). Note: usually remain the live and revise the parts thereafter.
- j) Click on the "Save" button to display the "Save successful" message, then set is to take effect.**

2)Flow Post

- a) Switch:** To turn on or off the main / secondary stream.
- b) Protocol:** primary / secondary stream are both use RTMP protocol.
- c) Host Port:** server port number (default 1935, 0-65535 optional)
- d) Host Address:** server IP addresses (default 192.168.5.11)
- e) Flow Name:** choose a different stream name (live / av0, live / av1 optional).
- f) User:** Set the user name.
- g) Password:** Set the password.
- h) Click on the "Save" button to display the "Save successful" message, then set is to take effect.**

3)Video Parameters

Focus:

- Focus Mode: set the focus mode (the default auto, manual optional)
- Focus range: set the focus range (the default middle, the upper and lower optional)
- Focus Sensitivity: Set the focus sensitivity (default is low, high, medium optional)

a) Exposure:

- Exposure Mode: Set the exposure mode (the default automatic, manual, shutter priority, aperture priority, Brightness priority optional)
- Exposure compensation: Exposure compensation setting is active when it is auto status (default is off).
- Exposure compensation value: Set the exposure compensation value, valid when it is set for auto (default 0, -7 to 7 optional).
- BLC: Set back light compensation, valid when it is auto status (default is off).
- Anti-flicker: Set up anti-flicker mode, valid when status of automatic, aperture or brightness priority (default 50Hz, closed, 60Hz optional).
- Gain limit: set the gain limits, auto, active when it is status of aperture or brightness priority (default 3, 0-15 optional).

b) Dynamic range: set the dynamic range (default 5, Off, 0-8 optional).

c) Shutter speed: active when it is status of manual or shutter-priority (default 1/100, 1/25, 1/30, 1/50, 1/60, 1/90, 1/100, 1/120, 1/180, 1/250, 1/350, 1/500, 1/1000, 1/2000, 1/3000, 1/4000, 1/6000, 1/10000 optional).

d) Aperture value: Set the aperture value, active when it is status of manual or aperture-priority (default F1.8, closed, F11, F9.6, F8.0, F6.8, F5.6, F4.8, F4.0, F3.4, F2.8, F2.4, F2.0, F1.8 optional).

e) Brightness: Set the brightness value, active when it is a state of brightness priority (default 7, 0-23 optional).

f) Color:

White balance modes: Set the white balance mode (the default automatic, 3000K, 4000K, 5000K, 6500K, manual, One-push optional). Note: Click the "Correction" button when selected the One-push white balance mode.

Red Gain: Set the red gain, effective when it is manual (default 255, 0-255 optional).

Blue Gain: Sets the Blue gain, effective when it is manual (default 199, 0-255 optional).

Saturation: Set the saturation (default 80%, 60%, 70%, 80%, 90%, 100%, 110%, 120%, 130%, optional).

Color: Set the chrome (default 7, 0-14 optional).

Auto white balance Sensitivity: Sensitivity Auto white balance settings (default is low, high, medium

optional).

Red Gain. Set Red Gain. Only effective when white balance mode is manual (default 255, 0~255 optional)

Blue Gain. Set Blue Gain. Only effective when white balance mode is manual (default 255, 0~255 optional)

g) Image:

- Brightness: Set the brightness (default 6,0-14 optional).
- Contrast: set the contrast (default 8,0-14 optional).
- Sharpness: Sets the sharpness value (default 7,0-15 optional).
- Black and white mode: Set black and white mode (default color, black/white optional).
- Gamma: Gamma value setting (default, 0.45,0.50,0.52,0.55 optional).
- Flip Horizontal: Set Flip Horizontal (default Off, On optional).
- Flip Vertical: Set vertical flip (default Off, On optional).

h) Noise Reduction:

- 2D Noise Reduction: Set 2D noise reduction level (default Auto, 1-7 and Off optional).
 - 3D Noise Reduction: Set 3D noise reduction level (default 5,1-8 and Off optional).
 - Dynamic dead pixel correction: Set Dynamic dead pixel correction (default Off,1-8 optional).
- Note: Click the "Refresh" to make revision of the a,b,c,d values become effective in the video.

1) Character-Overlapping

- a) Display date and time: Set whether to display the time and date (default display).
- B) Show Title: Set whether to display the title (default display).
- C) Time font color: Set the time and date font color (default white, black, yellow, red, blue optional).
- D) Title font color: Set the title font color (default white, black, yellow, red, blue optional).
- E) Moving characters: Set the date, time and title display position, click on the "up, down, left, right" buttons to move the corresponding character position.
- F) Title Content: Set title content (default CAMERA1).
- G) Time Content: Set time content (default 1970/01/10 05:36:00)
- H) Click on the "Save" button and display the "Save successful" message, then valid

2) Character Size

- a) Main stream character size: Set the character size of the display, the device will restart automatically after changed and saved (default 24,24,16 optional)
 - b) Secondary stream character size: Set the character size of the display, the device will restart automatically after changed and saved (default 16,24,16 optional)
- Click on the "Save" button to display "Parameter saved successfully" message, set to take effect

3) Video output

- a) Output Format: Set the video output format (default 1080P60,1080P50,1080P30,1080P25,1080I60,1080I50,720P60,720P50,720P30,720P25,1080P59.94,1080I59.94,1080P29.97,720P59.94,720P29.97 optional).
 - b) Click on the "Save" button to display the "Save successful" message, then valid.
- Note: Model S-S20/T20 support up to P30 video formats.

4.2.6、 Network configuration

1) Network port

- a) Data port: set the data port, the device will restart automatically after changed (default 3000,0-65535 optional).
 - b) Web Port: Set Web port, the device will restart automatically after changed (default is 80,0-65535 is optional).
 - c) Onvif Port: Set Onvif port, the device will restart automatically after changed (default 2000,0-65535 optional).
 - d) Soap Port: Set Soap port (default 1936,0-65535 optional).
 - e) RTMP Port: Set RTMP port (default 1935,0-65535 optional).
 - f) RTSP Port: Set RTSP port, the device will restart automatically after changed (default 554,0-65535 optional).
 - g) Visca Port: Set Visca port, the device will restart automatically after changed (default 3001,0-65535 optional).
- Click on the "Save" button to display the "Save successful" message, then valid.

2) Ethernet parameters

- a) DHCP: Set whether to open to obtain IP automatically. The machine will restart automatically after change (off by default)
 - b) IP Address: Set the IP address, the device will restart automatically after changes (default 192.168.5.163).
 - c) Note: Here is the IP address of the web page of the sign-in address
 - d) Subnet Mask: Set the subnet mask (default 255.255.5.0).
 - e) Default Gateway: Set the default gateway (default 0.0.0.0).
 - f) Physical Address: Set the physical address (the parameter is read-only but can not be modified).
- Click on the "Save" button to display the "Save successfully" message, then the set is to take effect (Note: To prevent IP conflicts When modify).

3) DNS parameters

- a) Preferred DNS server: set the preferred DNS server. (Default 0.0.0.0).

- b) Alternate DNS server: Alternate DNS server settings. (Default 0.0.0.0).
- c) Click on the "Save" button to display the "Save successfully" message, then the set is to take effect.

4)GB28181

- a) Switch: set whether open GB28181, can check
- b) Time Synchronization: whether synchronization time is set, you can check
- c) Stream Type: stream type setting (the default main stream, secondary stream optional)
- d) Sign effective time (in seconds): 3600 Range 5-65535
- e) Heartbeat time (seconds): 60 Range 1-65535
- f) Register ID: 34020000001320000001
- g) Register User name: IPC
- h) Register Password: 12345678
- i) Equipment ownership: Users can add their own
- j) Administrative regions: Users can add their own
- k) Alarm Zone: Users can add their own
- l) Equipment installation address: Users can add their own
- m) Local SIP Port: 5060 Range 0-65535
- n) GB28181 Server Address: IP address of the computer
- o) Server SIP Port: 5060 Range 0-65535
- p) Server ID: 34020000002000000001
- q) Click on the "Save" button to display "Parameter saved successfully" message, set to take effect

4.2.7、 System configuration

1)Device Properties

- a) Device Name: Set the device name (the default Camera1, user can add their own).
- b) Device ID: Set the device ID (default 1, Read-Only).
- c) System Language: Set the system language (default Simplified Chinese, English optional).Need to re-login after modify and save the setting.
- d) Click on the "Save" button to display the "Save successfully" message, then the set is to take effect..

2)System Time

- a) Date Format: Set the date format (YYYY-MM-DD default That year - month - day, MM-DD-YYYY namely Month - Day - Year, DD-MM-YYYY date - month - year Optional).
- b) Date separator: set the date separator (default '/',',','-' Optional).
- c) Time Zone: Set the time zone (default East eight districts, other time zones optional).
- d) Time Type: Set the time types (default 24 hours, optional 12 hours).
- e) Time setting: Set time mode (to choose the computer time synchronization,NTP server time synchronization, or set manually).
- f) Computer Time: Set the computer synchronization valid.
- g) Set the time manually. Click the calendar icon on the right to set the time manually. Effective when set manually.
- h) Update interval: Set the NTP server automatic updated time interval.Valid after setting NTP server synchronization (default one day, 2-10 days Optional).
- i) NTP server address or domain name: Set NTP server address or domain name (default time.nits.gov). Valid after setting NTP server synchronization.
- j) NTP Server Port: Sets the NTP server port (default 123).Valid after setting NTP server synchronization.
- k) Save. Click on the "Save" button to display the "Save successfully" message, then the set is to take effect.

3)User Management

- a) Select users: Set the user type (the default administrator, Common User 1, Common User 2 optional)
 - b) User name: set the user name (Select User Administrator default admin; select a common user1 default user1; to select a common user 2 default user2; user can modify their own)
 - c) Password: Set a password(Select User Administrator default admin; select a common user1 default user1; to select a common user 2 default user2; user can modify their own).
 - d) Password confirmation: Confirm the input passwords are the same or not.
 - e) Click on the "Save" button to display the "Save successfully" message, then the set is to take effect.
- Note:** Please note the case-sensitivity of the user name and password.
If login page by a common user's name and password , one does not have configuration privileges but can only operate to preview, playback, logoff.

4)Version upgrade

- a) MCU version V2.0.0.0 2015-12-18
- b) Camera version V2.0.0.16 2015-12-18

c) Focus version V2.0.0.6 2015-12-11

Note: Users only read the version information above which is consistent with the menu version but can not modify. Different types of the machine has different information.

r) Update file:

Click "Browse ..." installation, to select the upgrade file in the pop-up window.

Click on the "Upgrade" button, the upgrade dialog will appear. the device will reboot automatically after update successfully. (Note: make sure the power and network is keeping connected during the process.or the upgrade will fail)

5)Restore factory setting

a) Click on pop-up "Restore Factory Defaults" button and choose "yes" or "no", then the device will restart automatically and restore factory setting .

6) Reboot

a) Click on the pop-up "Reboot" button and choose "yes" or "no", then the device will restart automatically

4.2.8、 Logout

Click pop-up "logout" window and choose "yes" or "no", to choose to logout the present page and return to the user login page.

5、 Serial communication control

Under common working condition, the camera could be controlled through RS232/RS485

interface(VISCA),RS232C serial parameter are as follows:

Baud rate: 2400/4800/9600/115200 bits / sec; Start bit: 1; data bits: 8; Stop bit: 1; Parity: None.

After power on, the camera first go left, then back to the middle position. Self-test is finished after the zoom moved to the farthest and then back to the nearest position. If the camera saved 0 preset before, it will be back to that position after initialization. At this point, the user can control the camera by the serial commands.

5.1、 VISCA protocol list

5.1.1、 Camera return command (Correct)

Ack/Completion Message		
	Command packet	Note
ACK	z0 41 FF	Returned when the command is accepted.
Completion	z0 51 FF	Returned when the command has been executed.

z = camera address + 8

5.1.2 Camera return command (Wrongt)

Error Messages		
	Command packet	Note
Syntax Error	z0 60 02 FF	Returned when the command format is different or when a command with illegal command parameters is accepted
Command Not Executable	z0 61 41 FF	Returned when a command cannot be executed due to current conditions. For example, when commands controlling the focus manually are received during auto focus.

5.1.2、 Camera control command

Command	Function	Command packet	Note
AddressSet	Broadcast	88 30 01 FF	Address setting
IF_Clear	Broadcast	88 01 00 01 FF	I/F Clear
CommandCancel		8x 21 FF	
CAM_Power	On	8x 01 04 00 02 FF	Power ON/OFF
	Off	8x 01 04 00 03 FF	
CAM_Zoom	Stop	8x 01 04 07 00 FF	p = 0(low) - 7(high) pqrs: Zoom Position
	Tele(Standard)	8x 01 04 07 02 FF	
	Wide(Standard)	8x 01 04 07 03 FF	
	Tele(Variable)	8x 01 04 07 2p FF	
	Wide(Variable)	8x 01 04 07 3p FF	
	Direct	8x 01 04 47 0p 0q 0r 0s FF	
CAM_Focus	Stop	8x 01 04 08 00 FF	p = 0(low) - 7(high) pqrs: Focus Position
	Far(Standard)	8x 01 04 08 02 FF	
	Near(Standard)	8x 01 04 08 2p FF	
	Far(Variable)	8x 01 04 08 3p FF	
	Near (Variable)	8x 01 04 08 03 FF	
	Direct	8x 01 04 48 0p 0q 0r 0s FF	
	Auto Focus	8x 01 04 38 02 FF	
	Manual Focus	8x 01 04 38 03 FF	
CAM_Zoom Focus	Direct	8x 01 04 47 0p 0q 0r 0s 0t 0u 0v 0w FF	pqrs: Zoom Position tuvw: Focus Position
CAM_WB	Auto	8x 01 04 35 00 FF	
	3000K	8x 01 04 35 01 FF	
	4000k	8x 01 04 35 02 FF	
	One Push mode	8x 01 04 35 03 FF	
	5000k	8x 01 04 35 04 FF	
	Manual	8x 01 04 35 05 FF	
	6500k	8x 01 04 35 06 FF	
CAM_RGain	Reset	8x 01 04 03 00 FF	Manual Control of R Gain
	Up	8x 01 04 03 02 FF	
	Down	8x 01 04 03 03 FF	
	Direct	8x 01 04 43 00 00 0p 0q FF	pq: R Gain
CAM_Bgain	Reset	8x 01 04 04 00 FF	Manual Control of B Gain
	Up	8x 01 04 04 02 FF	
	Down	8x 01 04 04 03 FF	
	Direct	8x 01 04 44 00 00 0p 0q FF	pq: B Gain
CAM_AE	Full Auto	8x 01 04 39 00 FF	Automatic Exposure mode
	Manual	8x 01 04 39 03 FF	Manual Control mode
	Shutter priority	8x 01 04 39 0A FF	Shutter Priority Automatic Exposure

			mode
	Iris priority	8x 01 04 39 0B FF	Iris Priority Automatic Exposure mode
	Bright	8x 01 04 39 0D FF	Bright mode
CAM_Shutter	Reset	8x 01 04 0A 00 FF	Shutter Setting
	Up	8x 01 04 0A 02 FF	
	Down	8x 01 04 0A 03 FF	
	Direct	8x 01 04 4A 00 00 0p 0q FF	pq: Shutter Position
CAM_Iris	Reset	8x 01 04 0B 00 FF	Iris Setting
	Up	8x 01 04 0B 02 FF	
	Down	8x 01 04 0B 03 FF	
	Direct	8x 01 04 4B 00 00 0p 0q FF	pq: Iris Position
CAM_Gain	Reset	8x 01 04 0C 00 FF	Gain Setting
	Up	8x 01 04 0C 02 FF	
	Down	8x 01 04 0C 03 FF	
	Direct	8x 01 04 0C 00 00 0p 0q FF	pq: Gain Position
CAM_Bright	Reset	8x 01 04 0D 00 FF	Bright Setting
	Up	8x 01 04 0D 02 FF	
	Down	8x 01 04 0D 03 FF	
	Direct	8x 01 04 4D 00 00 0p 0q FF	pq: Bright Position
CAM_ExpComp	On	8x 01 04 3E 02 FF	Exposure Compensation ON/OFF
	Off	8x 01 04 3E 03 FF	
	Reset	8x 01 04 0E 00 FF	Exposure Compensation Amount Setting
	Up	8x 01 04 0E 02 FF	
	Down	8x 01 04 0E 03 FF	
	Direct	8x 01 04 4E 00 00 0p 0q FF	pq: ExpComp Position
CAM_Back Light	On	8x 01 04 33 02 FF	Back Light
	Off	8x 01 04 33 03 FF	Compensation
CAM_NR (2D)		8x 01 04 53 0p FF	P=0-7 0:OFF
CAM_NR (3D)		8x 01 04 54 0p FF	P=0-8 0:OFF
CAM_Gamma		8x 01 04 5B 0p FF	p = 0 – 4 0: Default 1: 0.47 2: 0.50 3: 0.52 4: 0.55
CAM_Flicker		8x 01 04 23 00 FF	OFF
		8x 01 04 23 01 FF	50HZ
		8x 01 04 23 02 FF	60HZ
CAM_Aperture	Reset	8x 01 04 02 00 FF	Aperture Control
	Up	8x 01 04 02 02 FF	
	Down	8x 01 04 02 03 FF	
	Direct	8x 01 04 42 00 00 0p 0q FF	pq: Aperture Gain
CAM_Memory	Reset	8x 01 04 3F 00 0p FF	p: Memory Number(=0 to 254)

	Set	8x 01 04 3F 01 0p FF	Corresponds to 0 to 9 on the Remote Commander
	Recall	8x 01 04 3F 02 0p FF	
CAM_LR_Reverse	On	8x 01 04 61 02 FF	Image Flip Horizontal ON/OFF
	Off	8x 01 04 61 03 FF	
CAM_PictureFlip	On	8x 01 04 66 02 FF	Image Flip Vertical ON/OFF
	Off	8x 01 04 66 03 FF	
CAM_ColorSaturation	Direct	8x 01 04 49 00 00 00 0p FF	P=0-7 0:60% 1:70% 2:80% 3:90% 4:100% 5:110% 6:120% 7:130%
CAM_IDWrite		8x 01 04 22 0p 0q 0r 0s FF	pqrs: Camera ID (=0000 to FFFF)
SYS_Menu	ON	8x 01 04 06 06 02 FF	Turn on the menu screen
	OFF	8x 01 04 06 06 03 FF	Turn off the menu screen
IR_Receive	ON	8x 01 06 08 02 FF	IR(remote commander)receive On/Off
	OFF	8x 01 06 08 03 FF	
IR_ReceiveReturn	On	8x 01 7D 01 03 00 00 FF	IR(remote commander)receive message via the VISCA communication ON/OFF
	Off	8x 01 7D 01 13 00 00 FF	
CAM_SettingReset	Reset	8x 01 04 A0 10 FF	Reset Factory Setting
CAM_Brightness	Direct	8x 01 04 A1 00 00 0p 0q FF	pq: Brightness Position
CAM_Contrast	Direct	8x 01 04 A2 00 00 0p 0q FF	pq: Contrast Position
CAM_Flip	OFF	8x 01 04 A4 00 FF	Single Command For Video Flip
	Flip-H	8x 01 04 A4 01 FF	
	Flip-V	8x 01 04 A4 02 FF	
	Flip-HV	8x 01 04 A4 03 FF	
CAM_VideoSystem	Set camera video system	8x 01 06 35 00 0p FF	P: 0~E Video format 0:1080P60 1:1080P50 2:1080i60 3:1080i50 4:720P60 5:720P50 6:1080P30 7:1080P25 8:720P30 9:720P25 A: 1080P59.94 B: 1080i59.94 C: 720P59.94

			D: 1080P29.97 E: 720P29.97
Pan_tilt Drive	Up	8x 01 06 01 VV WW 03 01 FF	VV: Pan speed 0x01 (low speed) to 0x18 (high speed) WW: Tilt speed 0x01 (low speed) to 0x14 (high speed) YYYY: Pan Position ZZZZ: Tilt Position
	Down	8x 01 06 01 VV WW 03 02 FF	
	Left	8x 01 06 01 VV WW 01 03 FF	
	Right	8x 01 06 01 VV WW 02 03 FF	
	Upleft	8x 01 06 01 VV WW 01 01 FF	
	Upright	8x 01 06 01 VV WW 02 01 FF	
	DownLeft	8x 01 06 01 VV WW 01 02 FF	
	DownRight	8x 01 06 01 VV WW 02 02 FF	
	Stop	8x 01 06 01 VV WW 03 03 FF	
	AbsolutePosition	8x 01 06 02 VV WW 0Y 0Y 0Y 0Y 0Z 0Z 0Z 0Z FF	
	RelativePosition	8x 01 06 03 VV WW 0Y 0Y 0Y 0Y 0Z 0Z 0Z 0Z FF	
	Home	8x 01 06 04 FF	
Reset	8x 01 06 05 FF		
Pan-tilt LimitSet	Set	8x 01 06 07 00 0W 0Y 0Y 0Y 0Y 0Z 0Z 0Z 0Z FF	W:1 UpRight 0:DownLeft YYYY: Pan Limit Position(TBD) ZZZZ: Tilt Limit Position(TBD)
	Clear	8x 01 06 07 01 0W 07 0F 0F 0F 07 0F 0F 0F FF	

5.1.3、 Inquiry command

Command	Function	Command packet	Note
CAM_PowerInq	8x 09 04 00 FF	y0 50 02 FF	On
		y0 50 03 FF	Off(Standby)
CAM_ZoomPosInq	8x 09 04 47 FF	y0 50 0p 0q 0r 0s FF	pqrs: Zoom Position
CAM_FocusAFModelInq	8x 09 04 38 FF	y0 50 02 FF	Auto Focus
		y0 50 03 FF	Manual Focus
CAM_FocusPosInq	8x 09 04 48 FF	y0 50 0p 0q 0r 0s FF	pqrs: Focus Position
CAM_WBModelInq	8x 09 04 35 FF	y0 50 00 FF	Auto
		y0 50 01 FF	3000K
		y0 50 02 FF	4000K
		y0 50 03 FF	One Push Mode
		y0 50 04 FF	5000K
		y0 50 05 FF	Manual
CAM_RGainInq	8x 09 04 43 FF	y0 50 00 00 0p 0q FF	pq: R Gain
CAM_BGainInq	8x 09 04 44 FF	y0 50 00 00 0p 0q FF	pq: B Gain
CAM_AEModelInq	8x 09 04 39 FF	y0 50 00 FF	Full Auto
		y0 50 03 FF	Manual
		y0 50 0A FF	Shutter priority
		y0 50 0B FF	Iris priority
CAM_ShutterPosInq	8x 09 04 4A FF	y0 50 00 00 0p 0q FF	pq: Shutter Position
CAM_IrisPosInq	8x 09 04 4B FF	y0 50 00 00 0p 0q FF	pq: Iris Position
CAM_BrightPosInq	8x 09 04 4D FF	y0 50 00 00 0p 0q FF	pq: Bright Position
CAM_ExpCompModelInq	8x 09 04 3E FF	y0 50 02 FF	On
		y0 50 03 FF	Off

CAM_ExpCompPosInq	8x 09 04 4E FF	y0 50 00 00 0p 0q FF	pp: ExpComp Position
CAM_BacklightModelInq	8x 09 04 33 FF	y0 50 02 FF	On
		y0 50 03 FF	Off
CAM_NRLevel(2D) Inq	8x 09 04 53 FF	y0 50 0p FF	P: 2DNRLLevel
CAM_NRLevel(3D) Inq	8x 09 04 54 FF	y0 50 0p FF	P:3D NRLevel
CAM_FlickerModelInq	8x 09 04 55 FF	y0 50 0p FF	p: Flicker Settings(0: OFF, 1: 50Hz, 2: 60Hz)
CAM_ApertureInq	8x 09 04 42 FF	y0 50 00 00 0p 0q FF	pp: Aperture Gain
CAM_PictureEffectModelInq	8x 09 04 63 FF	y0 50 00 FF	Off
		y0 50 04 FF	B&W
CAM_MemoryInq	8x 09 04 3F FF	y0 50 0p FF	p: Memory number last operated.
SYS_MenuModelInq	8x 09 06 06 FF	y0 50 02 FF	On
		y0 50 03 FF	Off
CAM_LR_ReverseInq	8x 09 04 61 FF	y0 50 02 FF	On
		y0 50 03 FF	Off
IR_ReceiveReturn		y0 07 7D 01 04 00 FF	Power ON/OFF
		y0 07 7D 01 04 07 FF	Zoom tele/wide
		y0 07 7D 01 04 38 FF	AF ON/OFF
		y0 07 7D 01 04 33 FF	Camera_Backlight
		y0 07 7D 01 04 3F FF	Camera_Memery
		y0 07 7D 01 06 01 FF	Pan_titleDriver
CAM_PictureFlipInq	8x 09 04 66 FF	y0 50 02 FF	On
		y0 50 03 FF	Off
CAM_ColorSaturationInq	8x 09 04 49 FF	y0 50 00 00 00 0p FF	p: Color Gain setting 0h (60%) to Eh (130%)
CAM_IDInq	8x 09 04 22 FF	y0 50 0p FF	p: Gamma ID
IR_ReceiveInq	8x 09 06 08 FF	y0 50 02 FF	On
		y0 50 03 FF	Off
CAM_BrightnessInq	8x 09 04 A1 FF	y0 50 00 00 0p 0q FF	pp: Brightness Position
CAM_ContrastInq	8x 09 04 A2 FF	y0 50 00 00 0p 0q FF	pp: Contrast Position
CAM_FlipInq	8x 09 04 A4 FF	y0 50 00 FF	Off
		y0 50 01 FF	Flip-H
		y0 50 02 FF	Flip-V
		y0 50 03 FF	Flip-HV
CAM_GammaInq	8x 09 04 5B FF	y0 50 0p FF	p: Gamma setting
CAM_VersionInq	8x 09 00 02 FF	y0 50 ab cd mn pq rs tu vw FF	ab cd : vender ID (0220) mn pq : model ID ST (0950) U3 (3950) rs tu : ARM Version vw : reserve
VideoSystemInq	8x 09 06 23 FF	y0 50 0p FF	P: 0~E Video format 0:1080P60 1:1080P50 2:1080i60 3:1080i50 4:720P60 5:720P50 6:1080P30 7:1080P25 8:720P30 9:720P25 A: 1080P59.94 B: 1080i59.94 C: 720P59.94 D: 1080P29.97 E: 720P29.97
Pan-tiltMaxSpeedInq	8x 09 06 11 FF	y0 50 ww zz FF	ww: Pan Max Speed zz: Tilt Max Speed
Pan-tiltPosInq	8x 09 06 12 FF	y0 50 0w 0w 0w 0w 0z 0z 0z 0z FF	www: Pan Position zzzz: Tilt Position

Note:

[X] in the above table indicates the camera address to be operated, **[y] = [x + 8]** .

5.2、Pelco-D protocol command list

Function	Byte1	Byte2	Byte3	Byte4	Byte5	Byte6	Byte7
Up	0xFF	Address	0x00	0x08	Pan Speed	Tilt Speed	SUM
Down	0xFF	Address	0x00	0x10	Pan Speed	Tilt Speed	SUM
Left	0xFF	Address	0x00	0x04	Pan Speed	Tilt Speed	SUM
Right	0xFF	Address	0x00	0x02	Pan Speed	Tilt Speed	SUM
Upleft	0xFF	Address	0x00	0x0C	Pan Speed	Tilt Speed	SUM
Upright	0xFF	Address	0x00	0x0A	Pan Speed	Tilt Speed	SUM
DownLeft	0xFF	Address	0x00	0x14	Pan Speed	Tilt Speed	SUM
DownRight	0xFF	Address	0x00	0x12	Pan Speed	Tilt Speed	SUM
Zoom In	0xFF	Address	0x00	0x20	0x00	0x00	SUM
Zoom Out	0xFF	Address	0x00	0x40	0x00	0x00	SUM
Focus Far	0xFF	Address	0x00	0x80	0x00	0x00	SUM
Focus Near	0xFF	Address	0x01	0x00	0x00	0x00	SUM
Set Preset	0xFF	Address	0x00	0x03	0x00	Preset ID	SUM
Clear Preset	0xFF	Address	0x00	0x05	0x00	Preset ID	SUM
Call Preset	0xFF	Address	0x00	0x07	0x00	Preset ID	SUM
Query Pan Position	0xFF	Address	0x00	0x51	0x00	0x00	SUM
Query Pan Position Response	0xFF	Address	0x00	0x59	Value High Byte	Value Low Byte	SUM
Query Tilt Position	0xFF	Address	0x00	0x53	0x00	0x00	SUM
Query Tilt Position Response	0xFF	Address	0x00	0x5B	Value High Byte	Value Low Byte	SUM
Query Zoom Position	0xFF	Address	0x00	0x55	0x00	0x00	SUM
Query Zoom Position Response	0xFF	Address	0x00	0x5D	Value High Byte	Value Low Byte	SUM

5.3、Pelco-P protocol command list

Function	Byte1	Byte2	Byte3	Byte4	Byte5	Byte6	Byte7	Byte8
Up	0xA0	Address	0x00	0x08	Pan Speed	Tilt Speed	0xAF	XOR
Down	0xA0	Address	0x00	0x10	Pan Speed	Tilt Speed	0xAF	XOR
Left	0xA0	Address	0x00	0x04	Pan Speed	Tilt Speed	0xAF	XOR
Right	0xA0	Address	0x00	0x02	Pan Speed	Tilt Speed	0xAF	XOR
Upleft	0xA0	Address	0x00	0x0C	Pan Speed	Tilt Speed	0xAF	XOR
Upright	0xA0	Address	0x00	0x0A	Pan Speed	Tilt Speed	0xAF	XOR

DownLeft	0xA0	Address	0x00	0x14	Pan Speed	Tilt Speed	0xAF	XOR
DownRight	0xA0	Address	0x00	0x12	Pan Speed	Tilt Speed	0xAF	XOR
Zoom In	0xA0	Address	0x00	0x20	0x00	0x00	0xAF	XOR
Zoom Out	0xA0	Address	0x00	0x40	0x00	0x00	0xAF	XOR
Focus Far	0xA0	Address	0x01	0x00	0x00	0x00	0xAF	XOR
Focus Near	0xA0	Address	0x02	0x00	0x00	0x00	0xAF	XOR
Set Preset	0xA0	Address	0x00	0x03	0x00	Preset ID	0xAF	XOR
Clear Preset	0xA0	Address	0x00	0x05	0x00	Preset ID	0xAF	XOR
Call Preset	0xA0	Address	0x00	0x07	0x00	Preset ID	0xAF	XOR
Query Pan Position	0xA0	Address	0x00	0x51	0x00	0x00	0xAF	XOR
Query Pan Position Response	0xA0	Address	0x00	0x59	Value High Byte	Value Low Byte	0xAF	XOR
Query Tilt Position	0xA0	Address	0x00	0x53	0x00	0x00	0xAF	XOR
Query Tilt Position Response	0xA0	Address	0x00	0x5B	Value High Byte	Value Low Byte	0xAF	XOR
Query Zoom Position	0xA0	Address	0x00	0x55	0x00	0x00	0xAF	XOR
Query Zoom Position Response	0xA0	Address	0x00	0x5D	Value High Byte	Value Low Byte	0xAF	XOR

6、 Camera Maintenance and Troubleshooting

6.1、 Camera Maintenance

- 1)If camera is not used for long time, please turn off power adapter switch and AC plug.
- 2)Use soft cloth or tissue to clean the camera cover.
- 3)Use soft cloth to clean the lens; Use neuter cleanser if bad smeared. No use strong or corrosive cleanser or corrosive cleanser avoiding scuffing.

6.2、 Troubleshooting

1)No video output

- a,Check whether the camera power supply is connected, the voltage is normal, the power indicator is lit.
- b,Whether the machine could do self-inspection after restarted.
- c,Check whether the video interface of camera and display is loosen
- d,Check whether the video output cable is worn.
- e,Check whether the camera video format is supported by the display.

2)No image sometimes

- a,Check whether the camera power supply is connected, the voltage is normal, the power indicator is lit.
- b. Check whether the video output or video display interfaces are normal.
- c. Check whether the video cable is damaged.

3)Image dithering when zoom-in or zoom-out

- a,Check whether the camera installation position is solid
- b,Whether there is shaking machine or objects around the camera

4) Serial port can not work.

- a,Check whether the camera serial device protocol, baud rate, address is consistent
- b,Check whether the control cable is connected properly
- c,Check whether the camera working mode is the normal operating mode.

5) Web pages can not log in

- a,Check whether the camera is showing normally.
- b,Check whether the network cable is connected properly(Ethernet port indicator is flashing)
- c,Check whether your computer is added the segment and the segment is consistent with the IP address of the camera
- d,Click "Start" and select "Run" and then type "cmd" in the computer;Click "OK" then turn on a DOS command window to enter ping 192.168.5.163. Press the Enter key to appear message as follows: Description network connection is normal

Copyright Notice:

All the contents of this manual and the copyright ownership belong to the company. Without the approval of the Company, no one can imitate, copy, reproduce or translate arbitrarily. This manual does not have any form of warranty, express or other imply. Specifications and information of this manual mentioned is just for informational purposes, and the content will be updated at any time without notice.

Copyright can not be reproduced.