



CH-1605RXV

4K UHD+ HDMI over HDBaseT 2.0 Receiver (PD)
with HDR/ARC



Operation Manual



HDMI[®]
HIGH-DEFINITION MULTIMEDIA INTERFACE

The terms HDMI, HDMI High-Definition Multimedia Interface, and the HDMI Logo are trademarks or registered trademarks of HDMI Licensing Administrator, Inc.

DISCLAIMERS

The information in this manual has been carefully checked and is believed to be accurate. Cypress Technology assumes no responsibility for any infringements of patents or other rights of third parties which may result from its use.

Cypress Technology assumes no responsibility for any inaccuracies that may be contained in this document. Cypress also makes no commitment to update or to keep current the information contained in this document.

Cypress Technology reserves the right to make improvements to this document and/or product at any time and without notice.

COPYRIGHT NOTICE

No part of this document may be reproduced, transmitted, transcribed, stored in a retrieval system, or any of its part translated into any language or computer file, in any form or by any means—electronic, mechanical, magnetic, optical, chemical, manual, or otherwise—without express written permission and consent from Cypress Technology.

© Copyright 2018 by Cypress Technology.

All Rights Reserved.

TRADEMARK ACKNOWLEDGMENTS

All products or service names mentioned in this document are trademarks of the companies with which they are associated.



SAFETY PRECAUTIONS

Please read all instructions before attempting to unpack, install or operate this equipment and before connecting the power supply. Please keep the following in mind as you unpack and install this equipment:

- Always follow basic safety precautions to reduce the risk of fire, electrical shock and injury to persons.
- To prevent fire or shock hazard, do not expose the unit to rain, moisture or install this product near water.
- Never spill liquid of any kind on or into this product.
- Never push an object of any kind into this product through any openings or empty slots in the unit, as you may damage parts inside the unit.
- Do not attach the power supply cabling to building surfaces.
- Use only the supplied power supply unit (PSU). Do not use the PSU if it is damaged.
- Do not allow anything to rest on the power cabling or allow any weight to be placed upon it or any person walk on it.
- To protect the unit from overheating, do not block any vents or openings in the unit housing that provide ventilation and allow for sufficient space for air to circulate around the unit.
- Please completely disconnect the power when the unit is not in use to avoid wasting electricity.

VERSION HISTORY

REV.	DATE	SUMMARY OF CHANGE
VS1	2018/12/14	Final technical review
VS2	2018/12/20	Updated Sections 6.3, 6.4

CONTENTS

1. Introduction	1
2. Applications	1
3. Package Contents	1
4. System Requirements	2
5. Features	2
6. Operation Controls and Functions	3
6.1 Front Panel.....	3
6.2 Rear Panel.....	4
6.3 IR Cable Pinouts.....	5
6.4 RS-232 Bypass Pinout	5
6.5 Serial Control (Via USB Port)	5
6.6 Serial Commands (Via USB Port)	6
7. Connection Diagram	7
8. Specifications	8
8.1 Technical Specifications	8
8.2 Video Specifications	9
8.3 Audio Specifications	10
8.4 Cable Specifications	11
8.5 HDBaseT Features.....	12
9. Acronyms	13



1. INTRODUCTION

This HDBaseT 2.0 Receiver provides for the reception of 4K video with HDR and high bitrate audio over a single Cat.6a/7 cable at distances of up to 100m (328 feet). This Receiver complies with the advanced HDCP 2.2 and HDMI 2.0 standards, as well as supporting the legacy HDCP 1.x and HDMI 1.x standards. Despite HDBaseT's 10.2Gbps bandwidth limitation, 4K UHD HDMI video sources, up to and including 4K@60Hz (4:4:4, 8-bit) as well as 10/12-bit sources with HDR, are able to be received and processed by the use of AVLC (Adaptive Visually Lossless Compression) when connected to a compatible AVLC Transmitter. This receiver can also pass RS-232, IR, Ethernet, and multiple audio streams across the same cable that carries the video signal.

The selectable Audio Return Channel (ARC)/bi-directional optical audio feature allows audio generated by an ARC-enabled TV to be sent back to the Transmitter and output over the optical output for local playback, or for optical audio to be exchanged bi-directionally between the Transmitter and Receiver. This Receiver is powered directly by the connected Transmitter, via 48V PoH (Power over HDBaseT), eliminating the need for a separate power supply for the Receiver.

2. APPLICATIONS

- Household entertainment sharing and control
- Lecture room display and control
- Showroom display and control
- Meeting room presentation and control
- Classroom display and control

3. PACKAGE CONTENTS

- 1×HDMI over HDBaseT 2.0 Receiver (PSE) with HDR/ARC
- 1×3.5mm to IR Extender Cable
- 1×Shockproof Feet (Set of 4)
- 1×Operation Manual

4. SYSTEM REQUIREMENTS

- HDMI receiving equipment such as an HDTV, monitor or audio amplifier.
- A compatible HDBaseT Transmitter with 48V PoH (PSE) support is required.
- An HDBaseT 2.0 Transmitter equipped with AVLC support is strongly recommended.
- The use of “Premium High Speed HDMI” cables, and industry standard Cat.6, Cat.6a or Cat.7, is highly recommended.

5. FEATURES

- HDMI with HDR, 3D & 4K@60Hz support, DVI 1.0 compatible
- HDCP 2.2 and HDCP 1.x compliant
- Supports up to 4K UHD (18Gbps, 4K@50/60Hz 4:4:4, 8-bit) video input and output
- Supports Deep Color input and output up to 12-bit
- Supports 10-bit and 12-bit HDR (High Dynamic Range) input/output
- Supports CEC bypass
- HDBaseT input receives video, audio and data over a single Cat.5e/6/7 cable and can reach distances up to 100m/328ft at 4K when using Cat.6a/7
- HDBaseT feature support: HD Video and Audio, 100BaseT Ethernet, 48V PoH (PD), bi-directional optical audio and Control (bi-directional IR/RS-232 pass-through)
- Integrated AVLC (Adaptive Visually Lossless Compression) allows for sources up to 18Gbps (600MHz) to be received from a compatible Transmitter with no loss of visual quality
- Selectable Audio Return Channel (ARC)/bi-directional optical audio functionality
- Powered via 48V PoH from Transmitter to Receiver

Note: A compatible PSE Transmitter providing 48V PoH is required to power this Receiver. Transmitters from other brands may not be compatible.

6. OPERATION CONTROLS AND FUNCTIONS

6.1 Front Panel

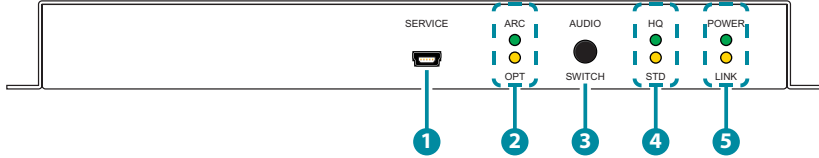

- 1 SERVICE Port:** This port is reserved for firmware update and serial control use only.
- 2 ARC & OPT LEDs:** These LEDs illuminate to indicate the current digital audio source selected for sending to a compatible Transmitter's optical output.

Note: Using ARC as a source requires the HDMI output to be connected to an ARC-compliant TV with ARC enabled.

- 3 AUDIO SWITCH Button:** This switch allows the user to select which digital audio source to send back to a compatible Transmitter. A single press toggles between modes.

ARC (Audio Return Channel): Sends the digital audio from a connected ARC-compliant TV's HDMI input.

OPT (Optical): Sends the digital audio from the Optical Input port.

- 4 HQ/STD LEDs:** These LEDs illuminate to indicate which AVLC mode is selected by the connected Transmitter: HQ (High Quality) or STD (Standard Quality).

- 5 POWER LED:** This LED will illuminate to indicate the unit is on and receiving power.

Note: A compatible 48V PSE Transmitter is required to power this Receiver.

LINK LED: This LED will illuminate solidly when a live connection with a compatible Transmitter is active.

6.2 Rear Panel

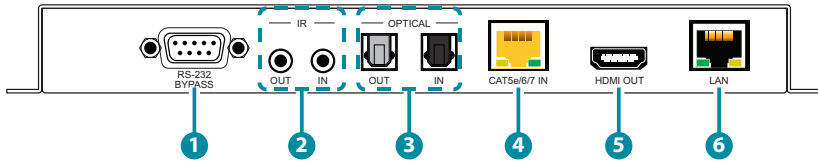

- 1 RS-232 BYPASS Port:** Connect to a PC, laptop or serial controllable device for the extension of RS-232 signals between both ends of the HDBaseT connection.
- 2 IR OUT Port:** Connect to an IR Blaster to transmit IR signals from the other end of the HDBaseT connection to devices within direct line-of-sight of the IR Blaster.

IR IN Port: Connect to the provided IR Extender to extend the IR control range of devices connected to the other end of the HDBaseT connection. Ensure that the remote being used is within direct line-of-sight of the IR Extender.
- 3 OPTICAL OUT Port:** Connect to powered speakers or an amplifier for digital audio output using an appropriate optical cable. Audio is sourced from the Optical Audio Input port on a connected compatible Transmitter.

OPTICAL IN Port: Connect to the optical audio output of a device such as a media player or game console using an appropriate optical cable. Audio is sent to the Optical Audio Output on a connected compatible Transmitter.
- 4 CAT5e/6/7 IN Port:** Connect to a compatible HDBaseT Transmitter with a single Cat.5e/6/7 cable for transmission of all data signals. 48V PoH will also be supplied when connected to a compatible PSE Transmitter.
- 5 HDMI OUT Port:** Connect to an HDMI TV, monitor or amplifier for digital video and audio output.
- 6 LAN Port:** Connect to an Ethernet supporting device or to your local network, as appropriate, to extend the network to both ends of the HDBaseT connection.

6.3 IR Cable Pinouts

IR Blaster Cable

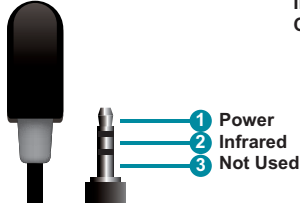

IR Extender Cable

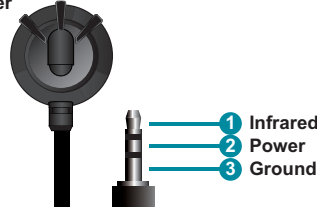

6.4 RS-232 Bypass Pinout

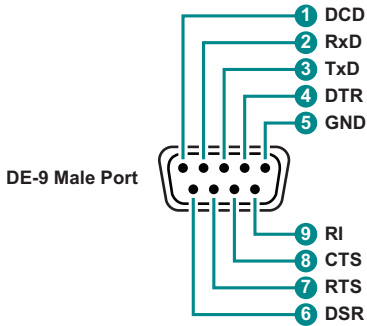

6.5 Serial Control (Via USB Port)

Serial Port Default Settings	
Baud Rate	19200
Data Bits	8
Parity Bit	None
Stop Bits	1
Flow Control	None

6.6 Serial Commands (Via USB Port)

COMMAND	
Description and Parameters	
help↵	Show the full command list.
?↵	Show the full command list.
get fw ver↵	Show the unit's current firmware version.
get model name↵	Show the unit's model name.
get model type↵	Show the unit's product type.
get power↵	Show the unit's current power state.
set system reboot↵	Reboot the unit.
set audio out A route N1↵	Route the specified audio input to the optical output on the Transmitter. Available values for N1 : 1 [Optical] 2 [ARC]
get audio out A route↵	Show the currently selected optical audio source type.
get transceiver compress rate↵	Show the unit's current compression quality setting (HQ or STD).

Note: Commands will not be executed unless followed by a carriage return. Commands are not case-sensitive.

7. CONNECTION DIAGRAM

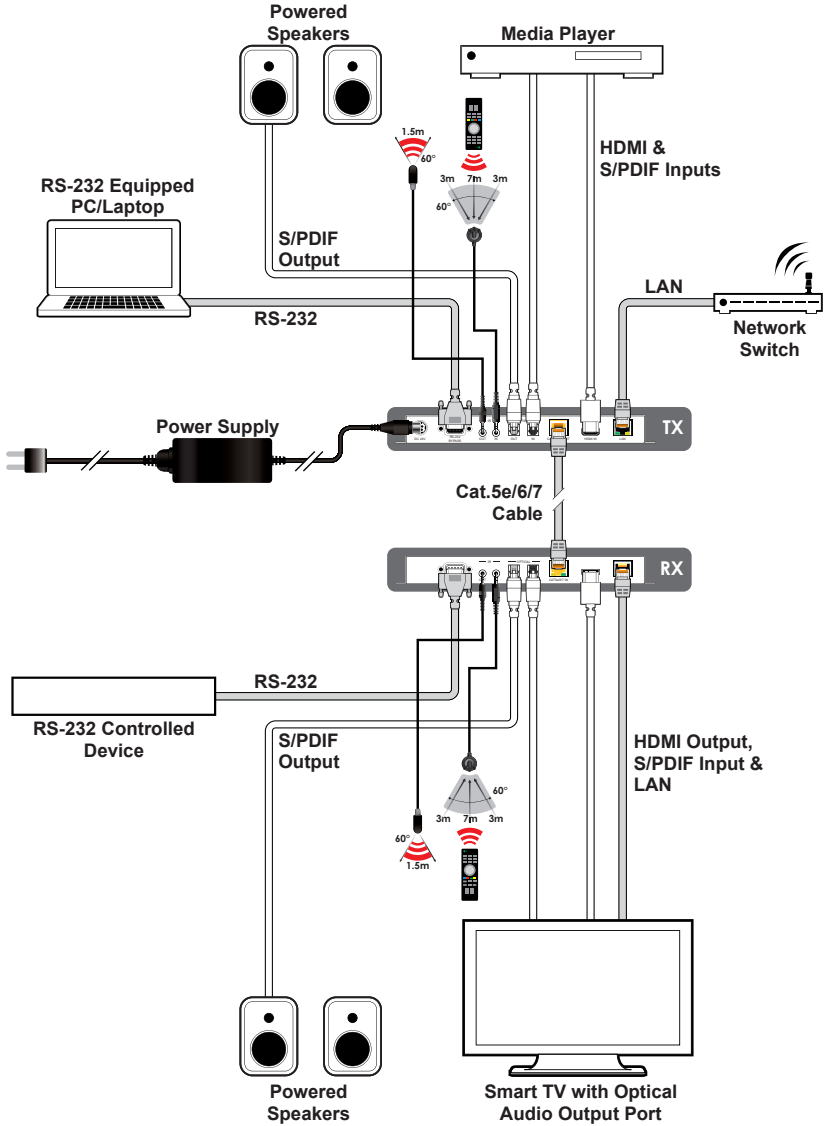

8. SPECIFICATIONS

8.1 Technical Specifications

HDMI Bandwidth	600MHz/18Gbps
HDBaseT Bandwidth	340MHz/10.2Gbps
Input Ports	1×HDBaseT (RJ-45) 1×S/PDIF (TOSLINK)
Output Ports	1×HDMI 1×S/PDIF (TOSLINK)
Pass-through Ports	1×IR Extender (3.5mm) 1×IR Blaster (3.5mm) 1×RS-232 (DE-9) 1×LAN (RJ-45)
Service/Control Port	1×USB (Mini-B)
IR Frequency	30 – 50kHz (30 – 60kHz under ideal conditions)
Baud Rate	Up to 115200
Power Supply	48V PoH
ESD Protection	Human Body Model: ±8kV (Air Discharge) ±4kV (Contact Discharge)
Dimensions	231.5mm×25mm×108mm (W×H×D) [Case Only] 231.5mm×25mm×115mm (W×H×D) [All Inclusive]
Weight	660g
Chassis Material	Metal (Steel)
Chassis Color	Black
Operating Temperature	0°C – 40°C/32°F – 104°F
Storage Temperature	-20°C – 60°C/-4°F – 140°F
Relative Humidity	20 – 90% RH (Non-condensing)
Power Consumption	8W

8.2 Video Specifications

Supported Resolutions (Hz)	Input	Output
	HDBaseT	HDMI
720×400@85	✓	✓
640×480@60/72/75/85	✓	✓
720×480i@60	✓	✓
720×480p@60	✓	✓
720×576i@50	✓	✓
720×576p@50	✓	✓
800×600@56/60/72/75/85	✓	✓
1280×720@50/60	✓	✓
1024×768@60/70/75/85	✓	✓
1280×768@60/75	✓	✓
1360×768@60	✓	✓
1366×768@60	✓	✓
1280×800@60	✓	✓
1152×864@75	✓	✓
1440×900@60	✓	✓
1280×960@60	✓	✓
1280×1024@60	✓	✓
1400×1050@60	✓	✓
1680×1050@60/60 (RB)	✓	✓
1920×1080i@50/60	✓	✓
1920×1080p@24/25/30/50/60	✓	✓
1600×1200@60	✓	✓
1920×1200@60 (RB)	✓	✓
2560×1440@60 (RB)	x	x
2560×1600@60 (RB)	x	x

Supported Resolutions (Hz)	Input	Output
	HDBaseT	HDMI
3840×2160@24/25/30	✓	✓
3840×2160@50/60 (4:2:0)	✓	✓
3840×2160@24/25/30, HDR10	AVLC	✓
3840×2160@50/60 (4:2:0), HDR10	AVLC	✓
3840×2160@50/60 (4:4:4)	AVLC	✓
4096×2160@24/25/30	✓	✓
4096×2160@50/60 (4:2:0)	✓	✓
4096×2160@24/25/30, HDR10	x	x
4096×2160@50/60 (4:2:0), HDR10	x	x
4096×2160@50/60 (4:4:4)	x	x

8.3 Audio Specifications

HDMI Input/Output	
LPCM	
Max Channels	8 Channels
Sampling Rate (kHz)	32, 44.1, 48, 88.2, 96, 176.4, 192
Bitstream	
Supported Formats	Standard & High-Definition

S/PDIF Input/Output	
LPCM	
Max Channels	2 Channels
Sampling Rate (kHz)	32, 44.1, 48, 88.2, 96, 176.4, 192
Bitstream	
Supported Formats	Standard

8.4 Cable Specifications

Cable Length	1080p		4K30	4K60
	8-bit	12-bit	(4:4:4) 8-bit	(4:4:4) 8-bit
High Speed HDMI Cable				
HDMI Output	15m	10m	5m	3m
Ethernet Cable				
Cat.5e/6	100m		90m	
Cat.6a/7	100m		100m	

- **1080p (FHD Video)**
 - Up to 1080p@60Hz, 12-bit color
 - Data rates lower than 5.3Gbps or below 225MHz TMDS clock
- **4K30 (UHD Video)**
 - 4K@24/25/30Hz & 4K@50/60Hz (4:2:0), 8-bit color
 - 4K@50/60Hz (4:4:4, 8-bit) with AVLC active
 - Data rates higher than 5.3Gbps or above 225MHz TMDS clock but below 10.2Gbps
- **4K60 (UHD+ Video)**
 - 4K@50/60Hz (4:4:4, 8-bit), AVLC required over HDBaseT
 - 4K@50/60Hz (4:2:0, 10-bit HDR), AVLC required over HDBaseT
 - Data rates higher than 10.2Gbps

8.5 HDBaseT Features

HDBaseT Feature Set	
Video & Audio	Supported
IR Pass-through	Supported
RS-232 Pass-through	Supported
Accept power from Transmitter	Supported
Send power to Transmitter	Unsupported
LAN Pass-through	Supported

9. ACRONYMS

ACRONYM	COMPLETE TERM
ARC	Audio Return Channel
AV	Audio/Video
AVLC	Adaptive Visually Lossless Compression
Cat.5e	Enhanced Category 5 cable
Cat.6	Category 6 cable
Cat.6a	Augmented Category 6 cable
Cat.7	Category 7 cable
CEC	Consumer Electronics Control
DVI	Digital Visual Interface
EDID	Extended Display Identification Data
HD	High-Definition
HDCP	High-bandwidth Digital Content Protection
HDMI	High-Definition Multimedia Interface
HDR	High Dynamic Range
HDTV	High-Definition Television
IP	Internet Protocol
IR	Infrared
LAN	Local Area Network
LED	Light-Emitting Diode
LPCM	Linear Pulse-Code Modulation
PC	Personal Computer
PD	Powered Device
PoH	Power over HDBaseT
PSE	Power Sourcing Equipment
S/PDIF	Sony/Philips Digital Interface Format
TCP	Transmission Control Protocol
UHD	Ultra-High-Definition
UHD+	Ultra-High-Definition Plus

ACRONYM	COMPLETE TERM
UHDTV	Ultra-High-Definition Television
USB	Universal Serial Bus



CYPRESS TECHNOLOGY CO., LTD.
www.cypress.com.tw
