



CH-2606RX

HDBaseT to HDMI/USB Receiver



Operation Manual



HDMI[®]
HIGH-DEFINITION MULTIMEDIA INTERFACE

The terms HDMI, HDMI High-Definition Multimedia Interface, and the HDMI Logo are trademarks or registered trademarks of HDMI Licensing Administrator, Inc.

DISCLAIMERS

The information in this manual has been carefully checked and is believed to be accurate. Cypress Technology assumes no responsibility for any infringements of patents or other rights of third parties which may result from its use.

Cypress Technology assumes no responsibility for any inaccuracies that may be contained in this document. Cypress also makes no commitment to update or to keep current the information contained in this document.

Cypress Technology reserves the right to make improvements to this document and/or product at any time and without notice.

COPYRIGHT NOTICE

No part of this document may be reproduced, transmitted, transcribed, stored in a retrieval system, or any of its part translated into any language or computer file, in any form or by any means—electronic, mechanical, magnetic, optical, chemical, manual, or otherwise—without express written permission and consent from Cypress Technology.

© Copyright 2018 by Cypress Technology.

All Rights Reserved.

TRADEMARK ACKNOWLEDGMENTS

All products or service names mentioned in this document are trademarks of the companies with which they are associated.



SAFETY PRECAUTIONS

Please read all instructions before attempting to unpack, install or operate this equipment and before connecting the power supply. Please keep the following in mind as you unpack and install this equipment:

- Always follow basic safety precautions to reduce the risk of fire, electrical shock and injury to persons.
- To prevent fire or shock hazard, do not expose the unit to rain, moisture or install this product near water.
- Never spill liquid of any kind on or into this product.
- Never push an object of any kind into this product through any openings or empty slots in the unit, as you may damage parts inside the unit.
- Do not attach the power supply cabling to building surfaces.
- Use only the supplied power supply unit (PSU). Do not use the PSU if it is damaged.
- Do not allow anything to rest on the power cabling or allow any weight to be placed upon it or any person walk on it.
- To protect the unit from overheating, do not block any vents or openings in the unit housing that provide ventilation and allow for sufficient space for air to circulate around the unit.
- Please completely disconnect the power when the unit is not in use to avoid wasting electricity.

VERSION HISTORY

REV.	DATE	SUMMARY OF CHANGE
RDV1	2019/04/25	Preliminary release



CONTENTS

1. Introduction	1
2. Applications	1
3. Package Contents	1
4. System Requirements	2
5. Features	2
6. Operation Controls and Functions	3
6.1 Front Panel.....	3
6.2 Rear Panel.....	4
6.3 IR Cable Pinouts.....	5
6.4 RS-232 Pinout and Defaults	5
7. Connection Diagram	6
8. Specifications	7
8.1 Technical Specifications	7
8.2 Video Specifications	8
8.3 Audio Specifications	10
8.3.1 Digital Audio	10
8.3.2 Analog Audio	10
8.4 Cable Specifications	11
8.5 HDBaseT Features.....	12
9. Acronyms	13





1. INTRODUCTION

This HDBaseT 2.0 Receiver is a great solution for receiving uncompressed HD audio and video as well as Ethernet and control via a single run of Cat.5e/6/7 cable over distances of up to 100 meters. Multiple data and control signal types are supported, including USB 2.0, IR, RS-232 and LAN connections. An independent balanced analog stereo audio output is also provided to support easy audio signal extension from compatible Transmitters. The HDBaseT input supports receiving resolutions up to a maximum of 4K@30Hz (4:4:4, 8-bit) or 4K@60Hz (4:2:0, 8-bit) from a compatible HDBaseT Transmitter.

When paired with this unit's standard Transmitter, 2 switchable USB 2.0 host (Type B) connections are available (1 on the Transmitter, 1 on the Receiver) which can connect to devices on up to 6 USB 2.0 (Type A) ports (3 on the Transmitter, 3 on the Receiver) forming a highly flexible KVM extension configuration (Note: Only 1 USB host may be active at a time).

This Receiver (PSE) can provide PoH (Power over HDBaseT) power to the connected HDBaseT Transmitter (PD) (compatible Transmitters only), allowing for greater flexibility within different installation scenarios. This unit is controllable via a front panel button.

2. APPLICATIONS

- Lecture room display and control
- Showroom display and control
- Meeting room presentation and control
- Classroom display and control

3. PACKAGE CONTENTS

- 1× HDBaseT to HDMI/USB Receiver
- 1× 24V/2.7A DC Power Adapter
- 1× 3.5mm to IR Blaster Cable
- 1× 3.5mm to IR Extender cable
- 1× Shockproof Feet (Set of 4)
- 1× Operation Manual

4. SYSTEM REQUIREMENTS

- HDMI receiving equipment such as an HDTV, monitor or audio amplifier.
- A compatible HDBaseT 2.0 Transmitter with PoH (PD) support is recommended.
- The use of Premium High Speed HDMI cables, and industry standard Cat.6, Cat.6a or Cat.7, is highly recommended.

5. FEATURES

- HDMI 2.0 and DVI 1.0 compatible
- HDCP 2.2 and HDCP 1.x compliant
- HDBaseT 2.0 compatible
- 1 HDBaseT input and 1 HDMI output
- 3 USB 2.0 Type A ports and 1 USB 2.0 Type B port
- Supports HDBaseT input resolutions up to 4K@60Hz (4:2:0, 8-bit)
- HDMI output supports resolutions up to 4K@60Hz (4:2:0, 8-bit)
- HDBaseT input receives video, audio, and data over a single Cat.5e/6/7 cable and can reach distances up to 100m/230ft at 4K when using Cat.6a/7
- HDBaseT feature support: HD Video and Audio, 100BaseT Ethernet, PoH (PSE), and control (bi-directional IR/RS-232/USB 2.0)
- Supports CEC bypass
- Supports pass-through of audio formats including LPCM (up to 8 channels), Bitstream and HD Bitstream from HDMI sources
- Reception of independent analog stereo audio extension
- Flexible USB host selection using the front panel button
Note: Multiple USB hosts may be connected at once (up to 2 total, between the Tx and a compatible Rx unit) with a single selected host active at a time
- Supports local power, or power via PoH from Receiver (PSE) to Transmitter (PD) (compatible Receivers only)
- Controllable via a front panel button

6. OPERATION CONTROLS AND FUNCTIONS

6.1 Front Panel

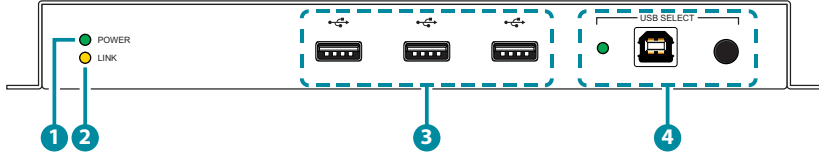

- 1 POWER LED:** This LED will illuminate to indicate the unit is on and receiving power.
- 2 LINK LED:** This LED will illuminate solidly when a live connection with a compatible Transmitter is active.
- 3 USB 2.0 (Type A) Ports:** Connect directly to standard USB 2.0 peripherals such as a mouse, keyboard or flash drive to extend their USB functionality to the designated Host Port.
- 4 USB SELECT Button & LED:** Press this button to toggle between the USB Host Ports on the Receiver or compatible Transmitter. The LED will illuminate to indicate which USB Host Port is currently active. If the LED is off, the USB Host Port on the connected Transmitter is active.

Note: Changing the USB host will force the HDBaseT connection to briefly disconnect while it reconfigures. The connected host (PC, laptop, etc.) may also take a moment to detect all available devices.

USB 2.0 (Type B) Port: Connect directly to a standard USB host such as a PC or laptop to extend its USB functionality to all currently connected USB devices.

Note: Multiple USB hosts may be connected at once (up to 2 total, between the Tx and a compatible Rx unit) with a single selected host active at a time

6.2 Rear Panel

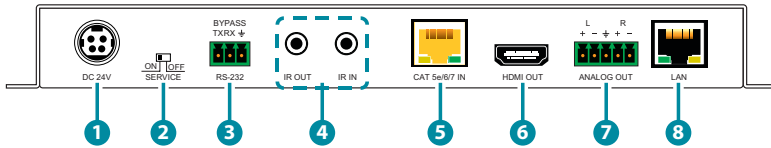

- 1 DC 24V Port:** Plug the 24V DC power adapter into this port and connect it to an AC wall outlet for power.
- 2 SERVICE Switch:** This switch is reserved for factory use only. The default setting is “OFF”.
- 3 BYPASS RS-232 Terminal Block:** Connect to a PC, laptop, or serial controllable device with a 3-pin adapter cable for the extension of RS-232 signals between both ends of the HDBaseT connection.
- 4 IR OUT Port:** Connect to the provided IR Blaster to transmit IR signals from the other end of the HDBaseT connection to devices within direct line-of-sight of the IR Blaster.

IR IN Port: Connect to the provided IR Extender to receive IR control signals and extend them to devices connected to the other end of the HDBaseT connection. Ensure that the remote being used is within direct line-of-sight of the IR Extender.
- 5 CAT 5e/6/7 IN Port:** Connect to a compatible HDBaseT Transmitter with a single Cat.5e/6/7 cable for reception of all data signals. PoH will also be supplied to a connected compatible PD Transmitter.
- 6 HDMI OUT:** Connect to HDMI TVs, monitors or amplifiers for digital video and audio output.
- 7 ANALOG OUT Terminal Block:** Connect to powered speakers or an amplifier for balanced analog stereo audio output. This will output the independent audio channel sent by compatible HDBaseT Transmitters.
- 8 LAN Port:** Connect to an Ethernet supporting device or to your local network, as appropriate, to extend the network to both ends of the HDBaseT connection.

6.3 IR Cable Pinouts

IR Blaster Cable

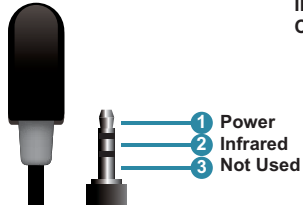

IR Extender Cable

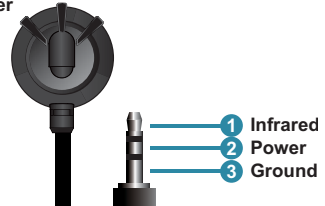

6.4 RS-232 Pinout and Defaults

3-pin Terminal Block

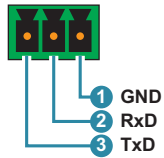

7. CONNECTION DIAGRAM

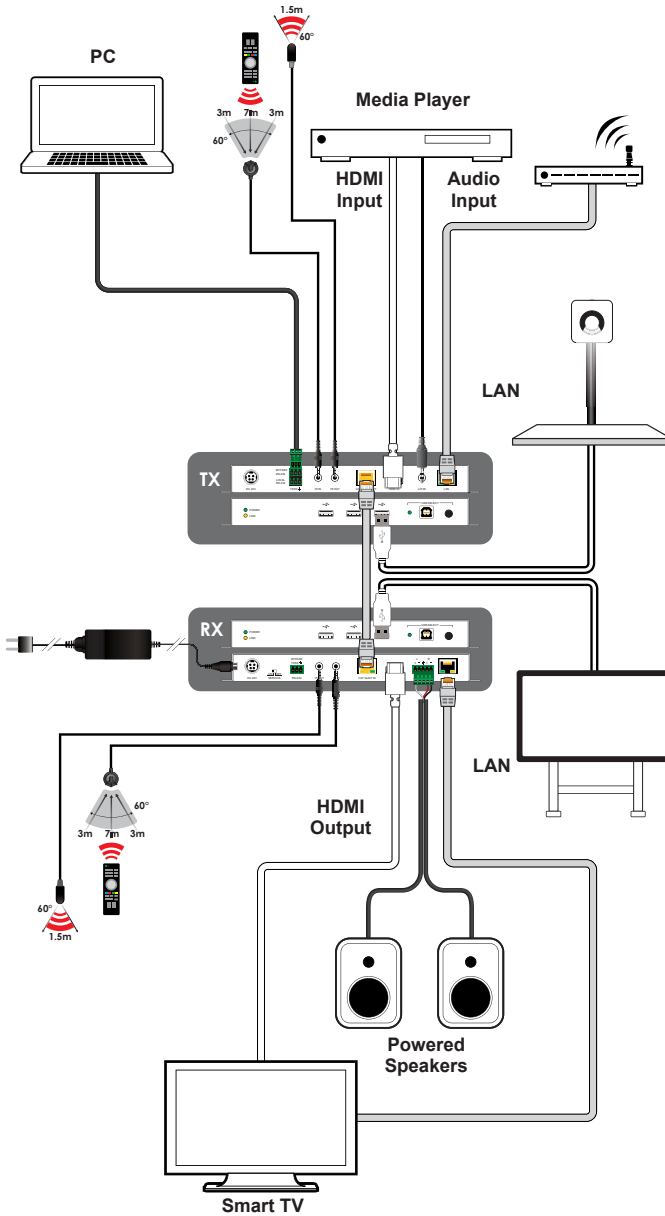

8. SPECIFICATIONS

8.1 Technical Specifications

HDMI Bandwidth	10.2Gbps
HDBaseT Bandwidth	10.2Gbps
Input Ports	1×HDBaseT (RJ-45)
Output Ports	1×HDMI (Type-A) 1×Stereo Audio (5-pin Terminal Block)
Pass-through Ports	1×IR Extender (3.5mm) 1×IR Blaster (3.5mm) 3×USB 2.0 (Type A) 1×USB 2.0 (Type B) 1×RS-232 (3-pin Terminal Block) 1×LAN (RJ-45)
IR Frequency	30 – 50kHz (30 – 60kHz under ideal conditions)
Baud Rate	Up to 115200
Power Supply	24V/2.7A DC (US/EU standards, CE/FCC/UL certified)
ESD Protection (HBM)	±8kV (Air Discharge) ±4kV (Contact Discharge)
Dimensions (W×H×D)	231.5mm×25mm×108mm [Case Only] 231.5mm×25mm×110mm [All Inclusive]
Weight	647g
Chassis Material	Metal (Steel)
Chassis Color	Black
Operating Temperature	0°C – 40°C/32°F – 104°F
Storage Temperature	-20°C – 60°C/-4°F – 140°F
Relative Humidity	20 – 90% RH (Non-condensing)
Power Consumption	40.44W

8.2 Video Specifications

Supported Resolutions (Hz)	Input	Output
	HDBaseT	HDMI
720×400p@70/85	✓	✓
640×480p@60/72/75/85	✓	✓
720×480i@60	✓	✓
720×480p@60	✓	✓
720×576i@50	✓	✓
720×576p@50	✓	✓
800×600p@56/60/72/75/85	✓	✓
848×480p@60	x	x
1024×768p@60/70/75/85	✓	✓
1152×864p@75	✓	✓
1280×720p@50/60	✓	✓
1280×768p@60/75/85	✓	✓
1280×800p@60/75/85	✓	✓
1280×960p@60/85	✓	✓
1280×1024p@60/75/85	✓	✓
1360×768p@60	✓	✓
1366×768p@60	✓	✓
1400×1050p@60	✓	✓
1440×900p@60/75	✓	✓
1600×900p@60RB	✓	✓
1600×1200p@60	✓	✓
1680×1050p@60	✓	✓
1920×1080i@50/60	✓	✓
1920×1080p@24/25/30	✓	✓
1920×1080p@50/60	✓	✓

Supported Resolutions (Hz)	Input	Output
	HDBaseT	HDMI
1920×1200p@60RB	✓	✓
2560×1440p@60RB	✓	✓
2560×1600p@60RB	✓	✓
2048×1080p@24/25/30	✓	✓
2048×1080p@50/60	✓	✓
3840×2160p@24/25/30	✓	✓
3840×2160p@50/60 (4:2:0)	✓	✓
3840×2160p@24, HDR10	x	x
3840×2160p@50/60 (4:2:0), HDR10	x	x
3840×2160p@50/60	x	x
4096×2160p@24/25/30	✓	✓
4096×2160p@50/60 (4:2:0)	✓	✓
4096×2160p@24, HDR10	x	x
4096×2160p@50/60 (4:2:0), HDR10	x	x
4096×2160p@50/60	x	x

8.3 Audio Specifications

8.3.1 Digital Audio

HDMI Input/Output	
LPCM	
Max Channels	8 Channels
Sampling Rate (kHz)	32, 44.1, 48, 88.2, 96, 176.4, 192
Bitstream	
Supported Formats	Standard & High-Definition

8.3.2 Analog Audio

Analog Output	
Max Audio Level	1Vrms
THD+N	< -80dB@0dBFS 1kHz (A-wt)
SNR	> 80dB@0dBFS
Frequency Response	< ± 1 dB@20Hz~20kHz
Crosstalk	< -80dB@10kHz
Impedance	470 Ω
Type	Balanced

8.4 Cable Specifications

Cable Length	1080p		4K30	4K60
	8-bit	12-bit	(4:4:4) 8-bit	(4:4:4) 8-bit
High Speed HDMI Cable				
HDMI Output	15m	10m	5m	×
Ethernet Cable				
Cat.5e/6	100m	90m	×	×
Cat.6a/7	100m	100m	×	×

Bandwidth Category Examples:

- **1080p (FHD Video)**
 - Up to 1080p@60Hz, 12-bit color
 - Data rates lower than 5.3Gbps or below 225MHz TMDS clock
- **4K30 (UHD Video)**
 - 4K@24/25/30Hz & 4K@50/60Hz (4:2:0), 8-bit color
 - Data rates higher than 5.3Gbps or above 225MHz TMDS clock but below 10.2Gbps
- **4K60 (UHD+ Video)**
 - 4K@50/60Hz (4:4:4, 8-bit)
 - 4K@50/60Hz (4:2:0, 10-bit HDR)
 - Data rates higher than 10.2Gbps

8.5 HDBaseT Features

HDBaseT Feature Set	Receiver
Video & Audio Extension	Supported
LAN Extension	Supported
Send power to Transmitter	Supported (PoH)
Accept power from Transmitter	Unsupported
IR Extension	Supported
RS-232 Extension	Supported
USB 2.0 Extension	Supported

9. ACRONYMS

ACRONYM	COMPLETE TERM
AV	Audio/Video
AVLC	Adaptive Visually Lossless Compression
AVR	Audio/Video Receiver or Recorder
Cat.5e	Enhanced Category 5 cable
Cat.6	Category 6 cable
Cat.6a	Augmented Category 6 cable
Cat.7	Category 7 cable
CEC	Consumer Electronics Control
CLI	Command-Line Interface
DAC	Digital-to-Analog Converter
DVI	Digital Visual Interface
EDID	Extended Display Identification Data
HD	High-Definition
HDBT	HDBaseT
HDCP	High-bandwidth Digital Content Protection
HDMI	High-Definition Multimedia Interface
HDR	High Dynamic Range
HDTV	High-Definition Television
IR	Infrared
KVM	Keyboard/Video/Mouse
LAN	Local Area Network
LED	Light-Emitting Diode
LPCM	Linear Pulse-Code Modulation
PC	Personal Computer
PD	Powered Device
PoH	Power over HDBaseT
PSE	Power Sourcing Equipment
SDTV	Standard-Definition Television

ACRONYM	COMPLETE TERM
UHD	Ultra-High-Definition (10.2Gbps)
UHD+	Ultra-High-Definition Plus (18Gbps)
UHDTV	Ultra-High-Definition Television
USB	Universal Serial Bus
VGA	Video Graphics Array
WUXGA (RB)	Widescreen Ultra Extended Graphics Array (Reduced Blanking)
XGA	Extended Graphics Array



CYPRESS TECHNOLOGY CO., LTD.
www.cypress.com.tw
