



# CH-2605TXV

4K UHD+ HDMI over HDBaseT 2.0 Transmitter (PD)  
with HDR/ARC



Operation Manual



## **DISCLAIMERS**

The information in this manual has been carefully checked and is believed to be accurate. Cypress Technology assumes no responsibility for any infringements of patents or other rights of third parties which may result from its use.

Cypress Technology assumes no responsibility for any inaccuracies that may be contained in this document. Cypress also makes no commitment to update or to keep current the information contained in this document.

Cypress Technology reserves the right to make improvements to this document and/or product at any time and without notice.

## **COPYRIGHT NOTICE**

No part of this document may be reproduced, transmitted, transcribed, stored in a retrieval system, or any of its part translated into any language or computer file, in any form or by any means—electronic, mechanical, magnetic, optical, chemical, manual, or otherwise—without express written permission and consent from Cypress Technology.

© Copyright 2018 by Cypress Technology.

All Rights Reserved.

## **TRADEMARK ACKNOWLEDGMENTS**

All products or service names mentioned in this document are trademarks of the companies with which they are associated.





## SAFETY PRECAUTIONS

Please read all instructions before attempting to unpack, install or operate this equipment and before connecting the power supply. Please keep the following in mind as you unpack and install this equipment:

- Always follow basic safety precautions to reduce the risk of fire, electrical shock and injury to persons.
- To prevent fire or shock hazard, do not expose the unit to rain, moisture or install this product near water.
- Never spill liquid of any kind on or into this product.
- Never push an object of any kind into this product through any openings or empty slots in the unit, as you may damage parts inside the unit.
- Do not attach the power supply cabling to building surfaces.
- Use only the supplied power supply unit (PSU). Do not use the PSU if it is damaged.
- Do not allow anything to rest on the power cabling or allow any weight to be placed upon it or any person walk on it.
- To protect the unit from overheating, do not block any vents or openings in the unit housing that provide ventilation and allow for sufficient space for air to circulate around the unit.
- Please completely disconnect the power when the unit is not in use to avoid wasting electricity.

## VERSION HISTORY

REV.	DATE	SUMMARY OF CHANGE
VS1	2018/12/20	Final technical review



# CONTENTS

<b>1. Introduction</b> .....	<b>1</b>
<b>2. Applications</b> .....	<b>1</b>
<b>3. Package Contents</b> .....	<b>2</b>
<b>4. System Requirements</b> .....	<b>2</b>
<b>5. Features</b> .....	<b>2</b>
<b>6. Operation Controls and Functions</b> .....	<b>4</b>
6.1 Front Panel .....	4
6.2 Rear Panel.....	5
6.3 IR Cable Pinouts .....	6
6.4 RS-232 Bypass Pinout.....	6
6.5 Serial Control (Via USB Port) .....	6
6.6 Serial Commands (Via USB Port) .....	7
<b>7. Connection Diagram</b> .....	<b>8</b>
<b>8. Specifications</b> .....	<b>9</b>
8.1 Technical Specifications .....	9
8.2 Video Specifications.....	10
8.3 Audio Specifications.....	11
8.4 Cable Specifications .....	12
8.5 HDBaseT Features.....	13
<b>9. Acronyms</b> .....	<b>13</b>





## 1. INTRODUCTION

This HDBaseT 2.0 Transmitter provides for the extension of 4K video with HDR and high bitrate audio over a single Cat.6a/7 cable at distances of up to 100m (328 feet). This Transmitter complies with the advanced HDCP 2.2 and HDMI 2.0 standards, as well as supporting the legacy HDCP 1.x and HDMI 1.x standards. Despite HDBaseT's 10.2Gbps bandwidth limitation, 4K UHD HDMI video sources, up to and including 4K@60Hz (4:4:4, 8-bit) as well as 10/12-bit sources with HDR, are able to be processed and extended by the use of AVLC (Adaptive Visually Lossless Compression) when connected to a compatible AVLC Receiver. This Transmitter can also pass RS-232, IR, Ethernet, and multiple audio streams across the same cable that carries the video signal.

The bi-directional optical audio feature allows optical audio to be exchanged bi-directionally between the Transmitter and Receiver. Rounding out the feature set is automatic HDBaseT clock stretching and TMDS re-clocking support. This Transmitter is powered directly by the connected Receiver, via 48V PoH (Power over HDBaseT), eliminating the need for a separate power supply for the Transmitter.

## 2. APPLICATIONS

- Household entertainment sharing and control
- Lecture room display and control
- Showroom display and control
- Meeting room presentation and control
- Classroom display and control

### 3. PACKAGE CONTENTS

- 1×HDMI over HDBaseT 2.0 Transmitter (PD) with HDR/ARC
- 1×3.5mm to IR Blaster Cable
- 1×Shockproof Feet (Set of 4)
- 1×Operation Manual

### 4. SYSTEM REQUIREMENTS

- HDMI source equipment such as a media player, video game console or set-top box.
- A compatible HDBaseT Receiver with 48V PoH (PSE) support is required.
- An HDBaseT 2.0 Receiver equipped with AVLC support is strongly recommended.
- The use of "Premium High Speed" HDMI cables, and industry standard Cat.6, Cat.6a or Cat.7, is highly recommended.

### 5. FEATURES

- HDMI with HDR, 3D & 4K@60Hz support, DVI 1.0 compatible
- HDCP 2.2 and HDCP 1.x compliant
- Supports up to 4K UHD (18Gbps, 4K@50/60Hz 4:4:4, 8-bit) video input and output
- Supports Deep Color input and output up to 12-bit
- Supports 10-bit and 12-bit HDR (High Dynamic Range) input/output
- Supports CEC bypass
- HDBaseT output transmits video, audio and data over a single Cat.5e/6/7 cable and can reach distances up to 100m/328ft at 4K when using Cat.6a/7
- HDBaseT feature support: HD Video and Audio, 100BaseT Ethernet, 48V PoH (PD), bi-directional optical audio and Control (bi-directional IR/RS-232 pass-through)
- Integrated AVLC (Adaptive Visually Lossless Compression) activates when the bandwidth requirements of the source are beyond 10.2Gbps (340MHz) allowing for sources up to 18Gbps (600MHz) to



be sent to a compatible Receiver with no loss of visual quality

- The AVLC feature allows manual selection between High Quality Mode (Full bandwidth) and Standard Mode (Lower bandwidth, useful for longer cable runs with 4K sources)
- Bi-directional optical audio extension support
- Supports HDMI DDC bus clock stretching for improved compatibility with certain Blu-ray players
- Performs TMDS re-clocking and signal re-generation for improved signal integrity
- Powered via 48V PoH from Receiver to Transmitter

*Note: A compatible PSE Receiver providing 48V PoH is required to power this Transmitter. Receivers from other brands may not be compatible.*

## 6. OPERATION CONTROLS AND FUNCTIONS

### 6.1 Front Panel

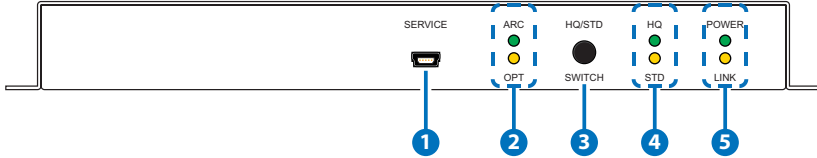

- 1 **SERVICE Port:** This port is reserved for firmware update and serial control use only.
- 2 **ARC & OPT LEDs:** These LEDs illuminate to indicate if the optical output source is coming from the optical input or ARC on the connected Receiver.

*Note: Selecting ARC as a source requires a compatible Receiver.*

- 3 **HQ/STD SWITCH Button:** This switch allows the user to select which compression mode to use when AVLC is required. A single press toggles between modes.

**HQ (High Quality)** mode uses the least amount of compression and provides the highest possible visual quality (perceptually identical to the original). In this mode, AVLC compression activates for any signal requiring more than 9Gbps.

**STD (Standard Quality)** mode applies additional signal reduction methods to lower the bandwidth requirements even further, improving transmission reliability at the cost of some visual fidelity. In this mode, AVLC compression activates for any signal requiring more than 7.5Gbps.

- 4 **HQ/STD LEDs:** These LEDs illuminate to indicate which AVLC mode is selected: HQ (High Quality) or STD (Standard Quality).
- 5 **POWER LED:** This LED will illuminate to indicate the unit is on and receiving power.

*Note: A compatible 48V PSE Receiver is required to power this Transmitter.*

**LINK LED:** This LED will illuminate solidly when a live connection with a compatible Receiver is active.

## 6.2 Rear Panel

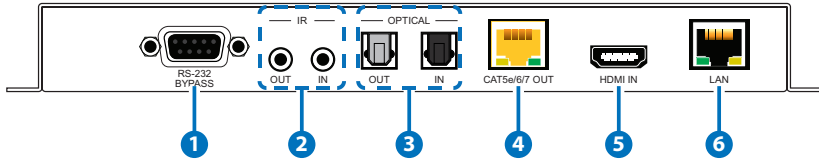

- 1 RS-232 BYPASS Port:** Connect to a PC, laptop or serial controllable device for the extension of RS-232 signals between both ends of the HDBaseT connection.
- 2 IR OUT Port:** Connect to the provided IR Blaster to transmit IR signals from the other end of the HDBaseT connection to devices within direct line-of-sight of the IR Blaster.  
**IR IN Port:** Connect to an IR Extender to extend the IR control range of devices connected to the other end of the HDBaseT connection. Ensure that the remote being used is within direct line-of-sight of the IR Extender.
- 3 OPTICAL OUT Port:** Connect to powered speakers or an amplifier for digital audio output using an appropriate optical cable. The audio is sourced from either the Optical Audio Input port or ARC of a connected compatible Receiver.  
**OPTICAL IN Port:** Connect to the optical audio output of a device such as a media player or game console using an appropriate optical cable. Audio is sent to the Optical Audio Output on a connected compatible Receiver.
- 4 CAT5e/6/7 OUT Port:** Connect to a compatible HDBaseT Receiver with a single Cat.5e/6/7 cable for transmission of all data signals. 48V PoH will also be supplied when connected to a compatible PSE Receiver.
- 5 HDMI IN Port:** Connect to HDMI source equipment such as a media player, game console or set-top box.
- 6 LAN Port:** Connect to an Ethernet supporting device or to your local network, as appropriate, to extend the network to both ends of the HDBaseT connection.

### 6.3 IR Cable Pinouts

IR Blaster Cable

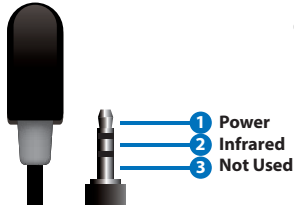

IR Extender Cable

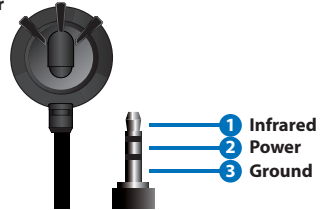

### 6.4 RS-232 Bypass Pinout

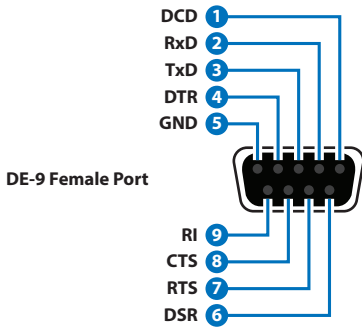

### 6.5 Serial Control (Via USB Port)

Serial Port Default Settings	
Baud Rate	19200
Data Bits	8
Parity Bit	None
Stop Bits	1
Flow Control	None

## 6.6 Serial Commands (Via USB Port)

COMMAND	
Description and Parameters	
<b>help↵</b>	Show the full command list.
<b>?↵</b>	Show the full command list.
<b>get fw ver↵</b>	Show the unit's current firmware version.
<b>get model name↵</b>	Show the unit's model name.
<b>get model type↵</b>	Show the unit's product type.
<b>get power↵</b>	Show the unit's current power state.
<b>set system reboot↵</b>	Reboot the unit.
<b>get audio out A route↵</b>	Show the currently selected optical audio source type from the connected Receiver (ARC or optical).
<b>set transceiver compress rate N1↵</b>	Set the compression quality used by the unit. Available values for <b>N1</b> : 1 [HQ (high quality)] 2 [STD (standard quality)]
<b>get transceiver compress rate↵</b>	Show the unit's current compression quality setting.

*Note: Commands will not be executed unless followed by a carriage return. Commands are not case-sensitive.*

## 7. CONNECTION DIAGRAM

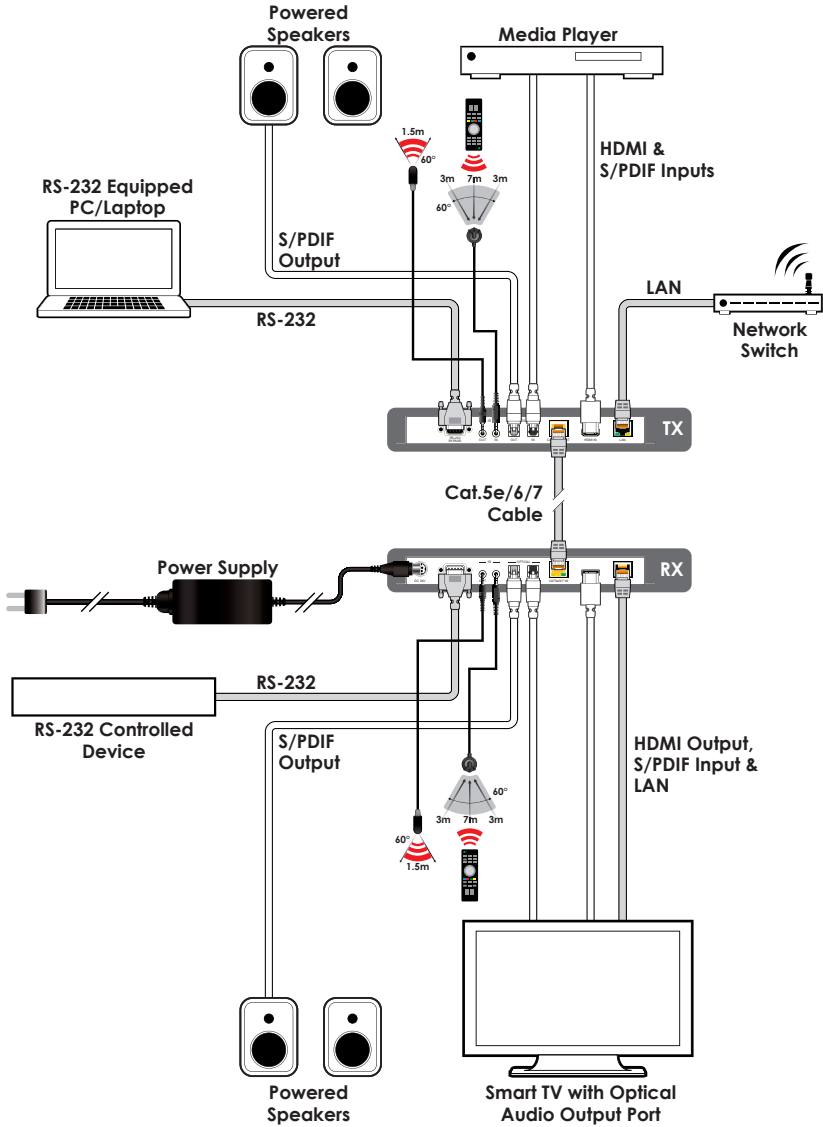



## 8. SPECIFICATIONS

### 8.1 Technical Specifications

<b>HDMI Bandwidth</b>	600MHz/18Gbps
<b>HDBaseT Bandwidth</b>	340MHz/10.2Gbps
<b>Input Ports</b>	1×HDMI 1×S/PDIF (TOSLINK)
<b>Output Ports</b>	1×HDBaseT (RJ-45) 1×S/PDIF (TOSLINK)
<b>Pass-through Ports</b>	1×IR Extender (3.5mm) 1×IR Blaster (3.5mm) 1×RS-232 (DE-9) 1×LAN (RJ-45)
<b>Service/Control Port</b>	1×USB (Mini-B)
<b>IR Frequency</b>	30 – 50kHz (30 – 60kHz under ideal conditions)
<b>Baud Rate</b>	Up to 115200
<b>Power Supply</b>	48V PoH (US/EU standards, CE/FCC/UL certified)
<b>ESD Protection</b>	Human Body Model: ±8kV (Air Discharge) ±4kV (Contact Discharge)
<b>Dimensions</b>	231.5mm×25mm×108mm (W×H×D) [Case Only] 231.5mm×25mm×115mm (W×H×D) [All Inclusive]
<b>Weight</b>	640g
<b>Chassis Material</b>	Metal (Steel)
<b>Chassis Color</b>	Black
<b>Operating Temperature</b>	0°C – 40°C/32°F – 104°F
<b>Storage Temperature</b>	-20°C – 60°C/-4°F – 140°F

<b>Relative Humidity</b>	20 – 90% RH (Non-condensing)
<b>Power Consumption</b>	5W

## 8.2 Video Specifications

Supported Resolutions (Hz)	Input	Output
	HDMI	HDBaseT
720×400@85	✓	✓
640×480@60/72/75/85	✓	✓
720×480i@60	✓	✓
720×480p@60	✓	✓
720×576i@50	✓	✓
720×576p@50	✓	✓
800×600@56/60/72/75/85	✓	✓
1280×720@50/60	✓	✓
1024×768@60/70/75/85	✓	✓
1280×768@60/75	✓	✓
1360×768@60	✓	✓
1366×768@60	✓	✓
1280×800@60	✓	✓
1152×864@75	✓	✓
1440×900@60	✓	✓
1280×960@60	✓	✓
1280×1024@60	✓	✓
1400×1050@60	✓	✓
1680×1050@60/60 (RB)	✓	✓
1920×1080i@50/60	✓	✓
1920×1080p@24/25/30/50/60	✓	✓
1600×1200@60	✓	✓

Supported Resolutions (Hz)	Input	Output
	HDMI	HDBaseT
1920×1200@60 (RB)	✓	✓
2560×1440@60 (RB)	×	×
2560×1600@60 (RB)	×	×
3840×2160@24/25/30	✓	✓
3840×2160@50/60 (4:2:0)	✓	✓
3840×2160@24/25/30, HDR10	✓	AVLC
3840×2160@50/60 (4:2:0), HDR10	✓	AVLC
3840×2160@50/60 (4:4:4)	✓	AVLC
4096×2160@24/25/30	✓	✓
4096×2160@50/60 (4:2:0)	✓	✓
4096×2160@24/25/30, HDR10	×	×
4096×2160@50/60 (4:2:0), HDR10	×	×
4096×2160@50/60 (4:4:4)	×	×

### 8.3 Audio Specifications

HDMI Input/Output	
LPCM	
Max Channels	8 Channels
Sampling Rate (kHz)	32, 44.1, 48, 88.2, 96, 176.4, 192
Bitstream	
Supported Formats	Standard & High-Definition

S/PDIF Input/Output	
LPCM	
<b>Max Channels</b>	2 Channels
<b>Sampling Rate (kHz)</b>	32, 44.1, 48, 88.2, 96, 176.4, 192
Bitstream	
<b>Supported Formats</b>	Standard

## 8.4 Cable Specifications

Cable Length	1080p		4K30	4K60
	8-bit	12-bit	(4:4:4) 8-bit	(4:4:4) 8-bit
High Speed HDMI Cable				
<b>HDMI Input</b>	15m	10m	5m	3m
Ethernet Cable				
<b>Cat.5e/6</b>	100m		90m	
<b>Cat.6a/7</b>	100m		100m	

- **1080p (FHD Video)**
  - Up to 1080p@60Hz, 12-bit color
  - Data rates lower than 5.3Gbps or below 225MHz TMDS clock
- **4K30 (UHD Video)**
  - 4K@24/25/30Hz & 4K@50/60Hz (4:2:0), 8-bit color
  - 4K@50/60Hz (4:4:4, 8-bit) with AVLC active
  - Data rates higher than 5.3Gbps or above 225MHz TMDS clock but below 10.2Gbps
- **4K60 (UHD+ Video)**
  - 4K@50/60Hz (4:4:4, 8-bit), AVLC required over HDBaseT
  - 4K@50/60Hz (4:2:0, 10-bit HDR), AVLC required over HDBaseT
  - Data rates higher than 10.2Gbps



## 8.5 HDBaseT Features

HDBaseT Feature Set	
Video & Audio	Supported
IR Pass-through	Supported
RS-232 Pass-through	Supported
Accept power from Receiver	Supported
Send power to Receiver	Unsupported
LAN Pass-through	Supported

## 9. ACRONYMS

ACRONYM	COMPLETE TERM
ARC	Audio Return Channel
AV	Audio/Video
AVLC	Adaptive Visually Lossless Compression
Cat.5e	Enhanced Category 5 cable
Cat.6	Category 6 cable
Cat.6a	Augmented Category 6 cable
Cat.7	Category 7 cable
CEC	Consumer Electronics Control
DVI	Digital Visual Interface
EDID	Extended Display Identification Data
HD	High-Definition
HDCP	High-bandwidth Digital Content Protection
HDMI	High-Definition Multimedia Interface
HDR	High Dynamic Range
HDTV	High-Definition Television
IP	Internet Protocol
IR	Infrared

<b>ACRONYM</b>	<b>COMPLETE TERM</b>
<b>LAN</b>	Local Area Network
<b>LED</b>	Light-Emitting Diode
<b>LPCM</b>	Linear Pulse-Code Modulation
<b>PC</b>	Personal Computer
<b>PD</b>	Powered Device
<b>PoH</b>	Power over HDBaseT
<b>PSE</b>	Power Sourcing Equipment
<b>S/PDIF</b>	Sony/Philips Digital Interface Format
<b>TCP</b>	Transmission Control Protocol
<b>UHD</b>	Ultra-High-Definition
<b>UHD+</b>	Ultra-High-Definition Plus
<b>UHDTV</b>	Ultra-High-Definition Television
<b>USB</b>	Universal Serial Bus



**CYPRESS TECHNOLOGY CO., LTD.**

[www.cypress.com.tw](http://www.cypress.com.tw)