

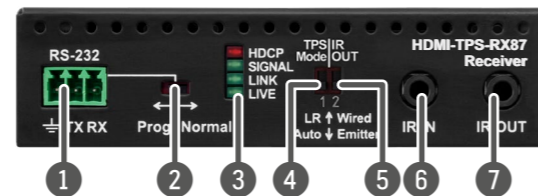

Quick Start Guide

HDMI-TPS-TX87
HDMI-TPS-RX87

Front View



Rear View

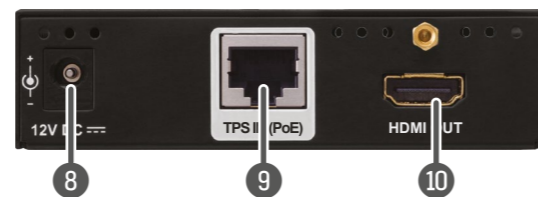

i The transmitter and the receiver have the same construction and connectors.

The product is compatible with any HDBaseT™



third-party devices.
HDBaseT™ and the HDBaseT Alliance logo are trademarks of the HDBaseT Alliance.

Front And Rear View – Legend

- 1 **RS-232 port** Local RS-232 port for bidirectional serial data connection and performing firmware update (programming).
- 2 **RS-232 switch** **Normal:** serial data is passed through the device. **Prog:** RS-232 pass-through function is disabled, the device is ready for the firmware update (see the figure below).
- 3 **Status LEDs** See the next section.
- 4 **TPS mode switch** **LR:** Longreach TPS mode; lower resolution (max 1080p), longer distances; **Auto:** TPS mode is determined automatically.
- 5 **IR mode switch** IR output signal modulation switch; the 38 kHz modulation can be switched On (**Emitter** position) or Off (**Wired** position).
- 6 **IR input** IR signal input connector (for 3.5 mm Jack, 3-pole, TRS plug).
- 7 **IR output** IR signal output connector (for 3.5 mm Jack, 2-pole, TS plug).
- 8 **DC input** 12V DC input for local power supply.
- 9 **TPS port** TPS port to the other compatible device (extender / matrix / board).
- 10 **HDMI port** Video port for DVI or HDMI signal.

Status LEDs

HDCP		
	OFF	Video output signal is not encrypted with HDCP.
	ON	Video output signal is encrypted with HDCP.
SIGNAL		
	OFF	No video signal transmission.
	ON	Video signal transmission.
LINK		
	OFF	TPS connection failed between the devices.
	BLINKING	TPS connection is detected and LPPF link mode is active.
	ON	TPS connection is detected and HDBT or LR link mode is active.
LIVE		
	OFF	No power supply or out of order.
	BLINKING	Device is powered and ready to use.

Important Safety Instructions

Please read the supplied safety instruction document before using the product and keep it available for future reference.

Introduction

TPS-TX87 and RX87 twisted pair HDBaseT™ extenders provide extension of uncompressed 4K/UHD video with embedded audio for long distances over a single CATx cable. The extender offers uni-directional RS-232 and IR pass-through on the same CATx cable that carries the video signal. The TPS extenders support full HDCP and EDID compliance and work on all standard AV resolutions and also 120 Hz 3D signals. PoE 48V remote powering is available through the single CATx cable, but a local power supply can also be used.

Box Contents

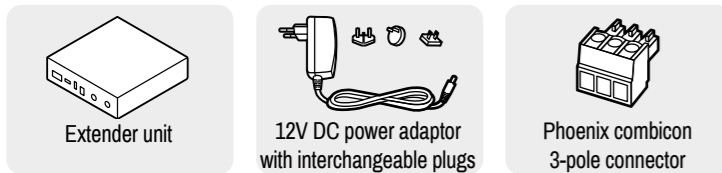

Compatible Devices

TPS-87 extenders are compatible with all Lightware devices with TPS port except the TPS-90 series.

Power Supply Options

TPS-87 extenders are compatible with IEEE 802.3af standard - Power over Ethernet (PoE) - and can receive power over the TPS line.

i The extenders are not compatible with TPS-95 extenders from remote power point of view. TPS-95 extenders have a different remote power feature, which is not PoE-compatible. Please always check the devices before connecting them to each other. If the remote power feature is disabled on the TPS-95 extender, it can be connected to a TPS-87 device.

The extenders can be powered:

- Locally with the supplied 12V DC adaptor or Lightware's rack mountable PSU,
- Remotely by a PoE-compatible Power Sourcing Equipment (PSE) device, like Lightware's power injector (TPS-PI-1P1) or a PoE-compatible matrix or matrix board.

If both supplying modes are available (local and remote), the remote power supply will be used.

! Do not connect any device to the TPS connector unless you are sure they are compatible! Connecting incompatible devices with similar connectors may cause harm to the devices.

i AWG 26 cables are not recommended with remote powering (reduce cable distances).

Connecting Steps

The layout below means the transmitter is powered locally by the power injector and they are placed close to each other. The receiver is powered remotely via the TPS cable (PoE).

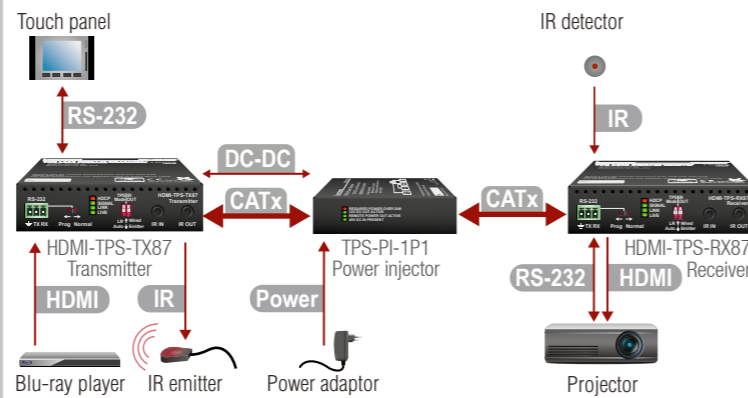

- CATx** Connect the TPS output port of the TX to the TPS port of the power injector by a CATx cable.
- CATx** Connect the TPS input port of the RX to the TPS+PoE port of the power injector by a CATx cable.
- DC-DC** Connect a DC-DC cable between the transmitter and the power injector.
- HDMI** Connect a source to the HDMI (DVI-D) input port of the transmitter.
- IR** Connect an IR emitter unit to the IR output port of the transmitter.
- RS-232** Connect a controller device to the local RS-232 port of the transmitter. Make sure the RS-232 switch is in the **Normal** position.
- HDMI** Connect a sink device to the HDMI (DVI-D) output port of the receiver.
- RS-232** Connect a serial cable between the sink device and the RS-232 port of the receiver.
- IR** Connect an IR detector unit to the IR input port of the receiver.
- Power** First, connect the power adaptor to the DC input of the power injector, then secondly to the AC power socket.

i Infrared emitter and detector units are optionally available accessories.

Locking DC Plug

The device has a locking DC connector to establish robust and safe power connection when local PSU is used.

Twist 90° clockwise to lock.

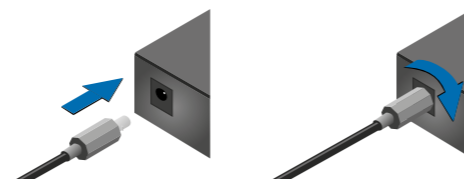

Mounting Options

Lightware offers three types of mounting accessories to fix the extenders:

Rack Shelf

1U high rack shelf provides mounting holes for the fastening of up to four extenders.



Mounting Steps:

! Always use the fixing screws that are supplied with the mounting accessory. If you insert screws longer than 6 mm, the device can be damaged.

- Unplug all the cables connected to the device(s).
- Turn the device(s) upside down.
- Put the shelf upside down on the device(s). Position it to get the mounting holes aligned.
- Fasten the device on the shelf with the provided screws.
- Fix the shelf to the desired place (screws are not supplied).

Under Desk Mounting Kit (UD-kit)

The UD-kit makes it easy to mount one extender under any flat surface (e.g. furniture).



UD Mounting Kit Double (UD-kit double)

The UD-kit double makes it easy to mount two extenders under any flat surface (e.g. furniture).



Port Diagram

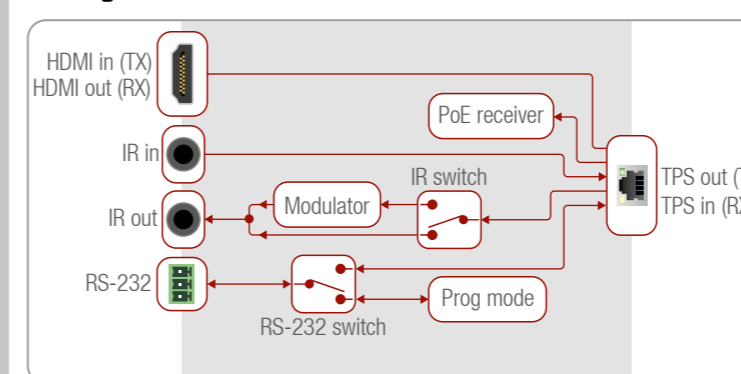

Installation of the Extender With a Matrix

- Power off all devices (installing with powered devices may harm them).
- Check the RS-232 switch(es) on the extender(s); they must be in Normal position for RS-232 pass-through function.
- The state of the TPS link mode switch makes no difference on the extender, because the connected board forces the extender to use the settings of the matrix.
- Check the PoE settings of the matrix or the matrix board (with the LDC software); each port can be set for remote powering separately.
- Pair the extender(s) and the matrix board(s) with CATx cable(s). The transmitters' TPS OUT with the input boards' TPS IN and the receivers' TPS IN with the output boards' TPS OUT.
- Connect the video source(s), sink(s) and the desired accessory device(s) to the matrix (MX-TPS boards don't support the IR pass-through).
- Connect the video source(s), sink(s) and the desired accessory device(s) to the extenders.
- To supply the extender(s) with remote power supply, connect the necessary power adaptor to the given matrix board.
- To supply the extenders locally, connect the supplied adaptor (12V 2A DC).
- Connect the power cord of the matrix into the outlet and switch on the matrix.
- Supply the other connected units.

TAKE CARE OF ME



I AM THE ONE AND ONLY
USER DOCUMENT FOR
THIS PRODUCT

Lightware Visual Engineering PLC.

Budapest, Hungary

sales@lightware.com +36 1 255 3800

support@lightware.com +36 1 255 3810

©2023 Lightware Visual Engineering. All rights reserved. All trademarks mentioned are the property of their respective owners. Specifications are subject to change without notice.

Further information on the device is available at www.lightware.com.

Doc. ver.: 1.3
19210097

Bi-directional Pass-through Data Lines

The direction of the video extension is fixed from TX towards RX, but the pass-through data lines are bi-directional*. It means the RS-232 and IR source and sink devices can be connected either to the TX or to the RX, and the signal is transmitted to the other extender.

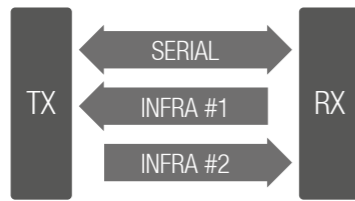

* In fact IR transmission is uni-directional, but the extender has two IR channels with different directions.

RS-232

Third-party devices with standard RS-232 port are supported, as the extenders work in „pass-through“ mode. TX and RX provide a 3-pole Phoenix connector. The RS-232 options – the baud rate and the parity bits – are set on the third-party devices and they can be anything. The extenders support any kind of serial settings.

Please find the RS-232 device type in its user guide; the extenders work as DCE devices.

RS-232 Switch Modes

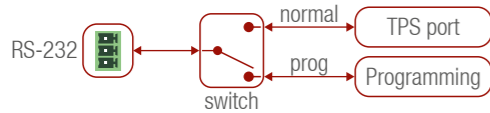

Infrared (IR)

One emitter and one detector is enough for remote controlling one IR sink device. If there is an IR sink device to be controlled next to the TX and the other one is next to the RX, two emitter-detector pairs are needed. The IR emitter and the detector have standard 3.5 mm TRS (jack) connectors. The emitter's plug has two poles (mono) and the detector's plug has three poles (stereo).

IR Output Mode Switch

The IR output signal modulation can be selected by the front panel switch as follows:

Detector – 3-pole-TRS		Emitter – 2-pole-TS	
1 Tip	Signal (active low)	1 Tip	+5V
2 Ring	GND	2 Ring	Signal (active low)
3 Sleeve	+5V	3 Sleeve	

- Emitter:** the 38 kHz modulation is switched on. In this case, an IR emitter can be connected to the IR output port.
- Wired:** the 38 kHz modulation is switched off. This option allows the connection of a cable between the IR output of the extender and the IR input port of the device desired to be remote controlled.

TPS Link Modes

The TPS working mode between the transmitter and the receiver parties is determined by the mode set in them. Both parties influence the setting that determines the final TPS transmission mode. The following TPS modes are defined:

- Long reach (LR):** Longer CATx cable length, less bandwidth (limited resolution). The LPPF mode is not available in LR TPS link mode.
- HDBaseT™ (HDBT):** more bandwidth (higher resolutions), shorter CATx cable length. If no video is present, the units change to LPPF mode automatically.
- Low Power Partial Functionality (LPPF):** Only RS-232 and IR are extended (@9600 baud).

Toggle Between TPS Link Modes

The toggle switch on the extenders can be used to toggle between the LR and Auto TPS modes. If both units have Auto state and there is valid video signal on the transmitter, the common mode will be HDBT. If the video signal disappears, devices go into LPPF mode.

The negotiated TPS working mode		Selected mode (RX)	
		LR	Auto
Selected mode (TX)	LR	LR	LR
	Auto	LR	Auto

TPS mode between an extender and a port of a matrix board

If an extender and a TPS matrix board are paired, the board forces the extender to use the settings of the matrix. The extender's TPS mode switch has no effect.

Always use the Auto mode with third-party devices!

Standalone Application

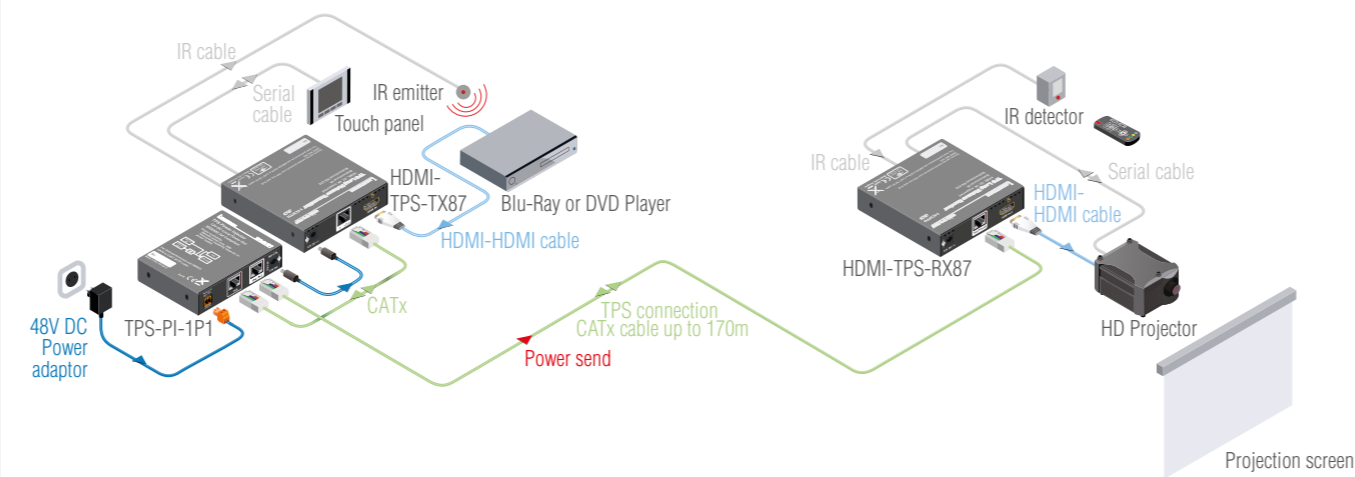

Application Diagram

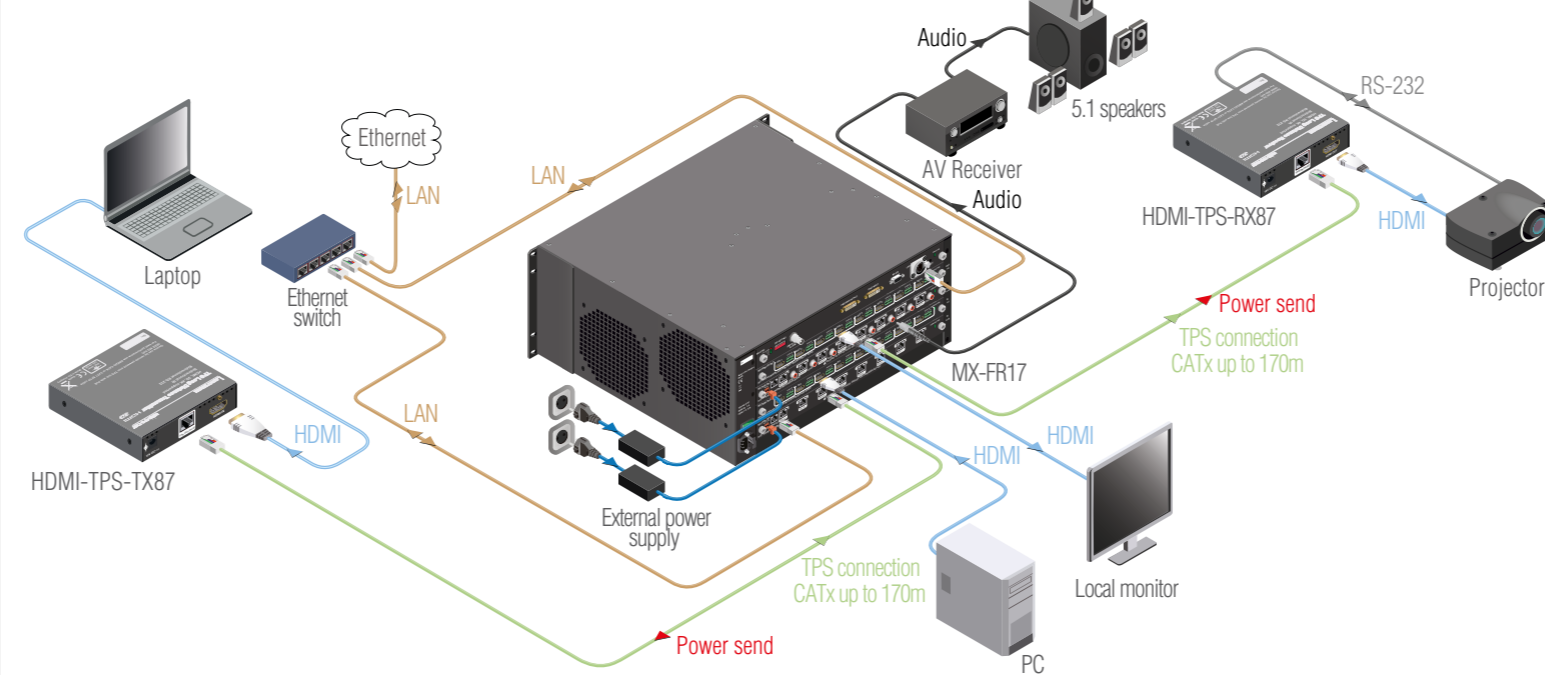

Wiring Guide for RS-232 Data Transmission

TPS-87 extenders are built with a 3-pole Phoenix connector. See the examples below of connecting to a DCE (Data Circuit-terminating Equipment) or a DTE (Data Terminal Equipment) type device:

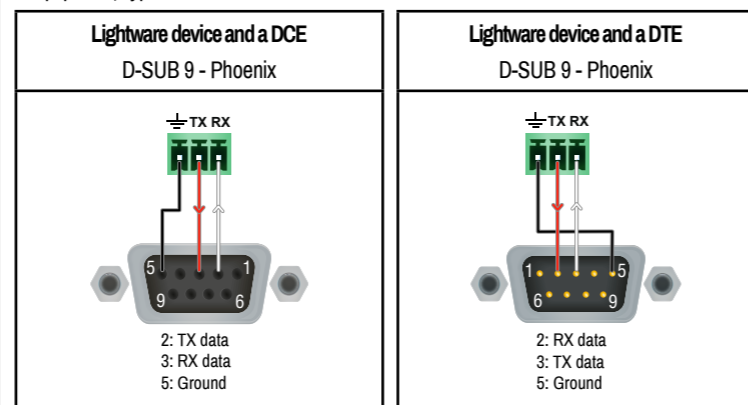

For more information about the cable wiring, see the [Cable Wiring Guide](#) on our website.

Maximum Extension Distances

Resolution	Pixel clock rate	Cable lengths (Auto / Long reach TPS mode)		
		CAT5e AWG24	CAT7 AWG26 **	CAT7 AWG23
1024x768@60Hz	65 MHz	100 m / 130 m*	90 m / 120 m*	120 m / 170 m*
1280x720p@60Hz	73.8 MHz	100 m / 130 m*	90 m / 120 m*	120 m / 170 m*
1920x1080p@60Hz (24bpp)	148.5 MHz	100 m / 130 m*	90 m / 120 m*	120 m / 170 m*
1920x1200@60Hz	152.9 MHz	100 m / NA	90 m / NA	120 m / NA
1600x1200@60Hz	162 MHz	100 m / NA	90 m / NA	120 m / NA
1920x1080@60Hz (36bpp)	223 MHz	70 m / NA	70 m / NA	100 m / NA
3840x2160@30Hz UHD	297 MHz	70 m / NA	70 m / NA	100 m / NA
4096x2160@30Hz 4K	297 MHz	70 m / NA	70 m / NA	100 m / NA

* Long reach TPS mode supports pixel clock frequencies up to 148.5 MHz.

** AWG 26 cables are not recommended with remote powering.

The values above are valid when the extender is powered by a local adaptor; distances may decrease depending on the powering mode (local or remote) and cable quality.

CAT7 SFTP AWG23 cable is always recommended.

Specification

General

Compliance	CE, UKCA
EMC (Emission)	EN 55032:2015+A1:2020
EMC (Immunity)	EN 55035:2017+A11:2020
Electrical safety	EN 62368-1:2020
RoHS	EN 63000:2018
Warranty	3 years
Operating temperature	0° to +50°C (+32° to +122°F)
Operating humidity	10% to 90%, non-condensing
Cooling	passive

Power

Power supply	power adaptor / PoE
Power consumption (TX)	4.5W (max)
Heat dissipation (TX)	16 BTU/h (max)
Power consumption (RX)	6.5W (max)
Heat dissipation (RX)	23 BTU/h (max)
Power over Ethernet (PoE)	via TPS port (IEEE 802.3af)

Power Adaptor

Supported power source	100-240 V AC; 50/60 Hz
Supplied power	12V DC, 2.5A
AC power plug	Interchangeable (EU, UK, JP/US, AUS/NZ)
DC power plug	Locking DC connector (2.1/5.5 mm pin)

Enclosure

Enclosure material	1 mm steel
Dimensions in mm	100.4 W x 100.4 D x 26 H
Dimensions in inch	4 W x 4 D x 1.1 H
Weight (TX)	285 g
Weight (RX)	305 g

Video Input

Connector type (HDMI transmitters)	19-pole HDMI Type A receptacle
A/V standard	DVI 1.0, HDMI 1.4a
HDCP compliance	HDCP 1.4
Color space	RGB, YCbCr
Video delay	0 frame
Supported resolutions at 8 bits/color *	up to 4096x2048@30Hz (4:4:4) or 4096x2048@60Hz (4:2:0) up to 3840x2160@30Hz (4:4:4) or 3840x2160@60Hz (4:2:0) 1920x1080@60Hz (4:4:4) up to 12 bits/color

Reclocking	Pixel Accurate Reclocking
3D support	yes
Control over CEC	yes **, transparent
EDID support	transparent

* All standard VESA, CEA and other custom resolutions up to 300MHz (HDMI1.4a) are supported.

Video Output

Connector type (HDMI receivers)	19-pole HDMI Type A receptacle
The specifications of the output port are the same as in the case of the input port.	

Connectors

TPS port	RJ45 (PoE-compatible)
IR input, output	3.5 mm (1.8") jack connector, pass-through mode
Serial port	3-pole Phoenix connector, pass-through mode