



CH-U331TXWPEU

UHD Video over IP Transmitter



Operation Manual

HDMI®
HIGH-DEFINITION MULTIMEDIA INTERFACE

The terms HDMI, HDMI High-Definition Multimedia Interface, and the HDMI Logo are trademarks or registered trademarks of HDMI licensing Administrator, Inc.

DISCLAIMERS

The information in this manual has been carefully checked and is believed to be accurate. Cypress Technology assumes no responsibility for any infringements of patents or other rights of third parties which may result from its use.

Cypress Technology assumes no responsibility for any inaccuracies that may be contained in this document. Cypress also makes no commitment to update or to keep current the information contained in this document.

Cypress Technology reserves the right to make improvements to this document and/or product at any time and without notice.

COPYRIGHT NOTICE

No part of this document may be reproduced, transmitted, transcribed, stored in a retrieval system, or any of its part translated into any language or computer file, in any form or by any means—electronic, mechanical, magnetic, optical, chemical, manual, or otherwise—without express written permission and consent from Cypress Technology.

© Copyright 2018 by Cypress Technology.

All Rights Reserved.

TRADEMARK ACKNOWLEDGMENTS

All products or service names mentioned in this document are trademarks of the companies with which they are associated.



SAFETY PRECAUTIONS

Please read all instructions before attempting to unpack, install or operate this equipment and before connecting the power supply. Please keep the following in mind as you unpack and install this equipment:

- Always follow basic safety precautions to reduce the risk of fire, electrical shock and injury to persons.
- To prevent fire or shock hazard, do not expose the unit to rain, moisture or install this product near water.
- Never spill liquid of any kind on or into this product.
- Never push an object of any kind into this product through any openings or empty slots in the unit, as you may damage parts inside the unit.
- Do not attach the power supply cabling to building surfaces.
- Use only the supplied power supply unit (PSU). Do not use the PSU if it is damaged.
- Do not allow anything to rest on the power cabling or allow any weight to be placed upon it or any person walk on it.
- To protect the unit from overheating, do not block any vents or openings in the unit housing that provide ventilation and allow for sufficient space for air to circulate around the unit.
- Please completely disconnect the power when the unit is not in use to avoid wasting electricity.

REVISION HISTORY

REV.	DATE	SUMMARY OF CHANGE
RDV1	2020/05/07	Preliminary release



CONTENTS

1. Introduction	1
2. Applications	1
3. Package Content	2
4. System Requirements	2
5. Features	3
6. Operation Controls and Functions	4
6.1 Front Panel.....	4
6.2 Rear Panel.....	6
6.3 IR Cable Pinouts.....	7
6.4 RS-232 Pinout and Defaults	7
6.5 WebGUI Control	8
6.5.1 System Tab.....	10
6.5.2 Video Wall Tab.....	13
6.5.3 Network Tab	16
6.5.4 Functions Tab.....	18
6.6 Telnet Control	21
6.7 Telnet Commands.....	21
7. Connection Diagram	30
8. Specifications	31
8.1 Technical Specifications	31
8.2 Video Specifications	32
8.3 Audio Specifications	34
8.3.1 Digital Audio	34
8.3.2 Analog Audio	34
8.3.3 AVoIP Audio Availability	35
8.4 Cable Specifications	36
9. Acronyms	37



1. INTRODUCTION

The AVoIP wall plate transmitter forms a part of a 4K UHD multi-function extension system that is able to extend HDMI or VGA signals along with analog audio, USB 2.0, IR and serial data using the TCP/IP protocol over regular Gigabit Ethernet networks. When using standard Ethernet cables, this system supports the extension of AVoIP signals up to 100 meters and the extension distance can be further extended (up to 100m per segment) by using gigabit network switches. This allows the user to cascade the system without signal loss or introducing delay. The USB functionality allows the system to act like a remote USB hub which provides a flexible remote KVM platform.

When the extension system's units are in multicast mode, a single AV signal can be sent to a large number of receivers within the same local network without the additional receivers increasing the bandwidth requirements. Additionally, that same multicast signal can be used to create large multi-display video walls with amazing simplicity. When combined with the optional IP Master Controller the functionality of the system expands exponentially. Its centralized web-based interface greatly simplifies control and management of large distributed video matrix or video wall systems adding to their flexibility in large home or commercial installations.

Configuration information is provided via OSD (On Screen Display) and control is via WebGUI, Telnet or the IP Master Controller (Optional).

2. APPLICATIONS

- HDMI, VGA, USB, Audio, IR, and RS-232 extension
- Multimedia display on a large number of displays via multicast
- Hotel or convention center display multi-monitor broadcast
- Long distance data and video transmission via cascading
- Distributed video matrix system
- Distributed video wall system
- Remote KVM control of a system

3. PACKAGE CONTENT

- 1× UHD Video over IP Transmitter
- 1× IR Extender Cable
- 1× IR Blaster Cable
- 1× Operation Manual

4. SYSTEM REQUIREMENTS

- HDMI or VGA source equipment such as media players, video game consoles, PCs, or set-top boxes.
- Analog audio receiving equipment such as headphones, audio amplifiers or powered speakers.
- A Gigabit Ethernet network switch with PoE (802.3af or better) and jumbo frame support is required. (8K jumbo frames are strongly recommended.)
- A Gigabit Ethernet switch with “IGMP snooping” enabled is required for multicast support.

5. FEATURES

- HDMI 2.0 and DVI 1.0 compatible
- HDCP 1.4 & 2.2 compliant
- 1 HDMI input & 1 VGA input
- Video, audio and control transmission over TCP/IP in Unicast (point-to-point) or Multicast (single-to-many) modes
- HDMI input supports resolutions up to 4K@60Hz (4:2:0, 8-bit) or 4K@30Hz (4:4:4, 8-bit)
Note: 4K@50/60Hz (YUV 4:2:0) sources are automatically converted to 4K@25/30Hz (RGB) prior to transmission
- VGA input supports resolutions up to WUXGA(RB)
- Supports the extension of many audio formats including 8 channel LPCM and Bitstream
- Supports generating video walls consisting of up to 16 displays
- By default, the analog Line In is automatically embedded in the streaming output when the VGA input is selected
- The Mic In on a linked receiver sends audio directly to the analog Line Out on the transmitter
- Powered directly by PoE (802.3af) from the connected Gigabit Ethernet switch
- Supports USB host device extension allowing the remote connection of a keyboard, mouse or storage
- Supports IR and RS-232 bypass
- Supports automatic input switching on signal loss
- Unit can be controlled via WebGUI and Telnet, and supports the use of an external control center (IP Master Controller) to provide expanded functionality (Contact your authorized dealer for more information)

6. OPERATION CONTROLS AND FUNCTIONS

6.1 Front Panel

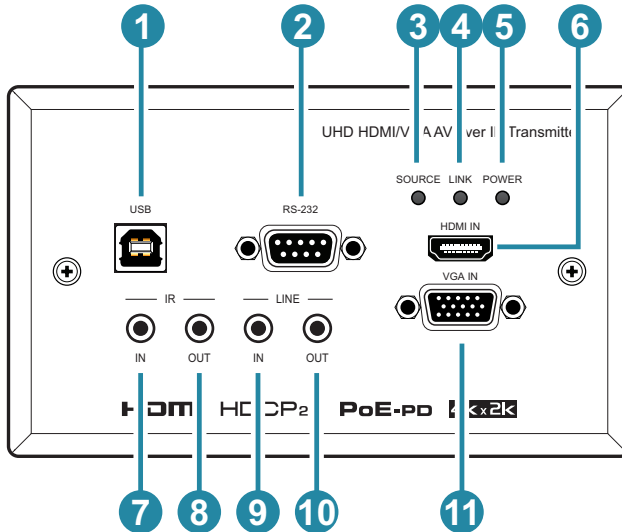

1 USB 2.0 (Type-B) Port: Connect directly to a PC, or other USB host device, to extend its USB functionality to the ports on the connected receiver.

2 RS-232 Port: Connect directly to your PC/laptop to send commands to RS-232 devices connected to the linked receiver. The baud rate is configurable, but the default baud rate is 115200.

Note: When the transmitter is in multicast mode every connected receiver unit can send RS-232 commands to the transmitter and commands sent from the transmitter side will be sent to all associated receivers.

3 SOURCE LED: This LED will illuminate red when an HDMI source is live and green when a VGA source is live. If no live sources are detected, this LED will remain off.

4 LINK LED: If the transmitter has no network connection the LINK LED will not illuminate. While the transmitter is attempting to establish a connection with a receiver the LINK LED will flash. When the transmitter has established a stable connection with a receiver the LINK LED will illuminate solidly.

- 5 **POWER LED:** This LED will flash while the unit is powering on and will illuminate solidly once it is ready to be used.
- 6 **HDMI IN Port:** Connect to HDMI source equipment such as a media player, game console or set-top box.
- 7 **IR IN Port:** Connect to the provided IR Extender to extend the IR control range of remotely located devices. Ensure that the remote being used is within direct line-of-sight of the IR Extender.

Note: When the transmitter is in multicast mode the IR signal is sent to all associated receivers.

- 8 **IR OUT Port:** Connect to the provided IR Blaster to transmit IR signals sent from the associated receiver to devices within direct line-of-sight of the remote IR Blaster.

- 9 **LINE IN Port:** Connect to the stereo analog output of a device such as a CD player or PC.

Note: By default, the analog Line In is automatically embedded with the VGA input in the streaming output.

- 10 **LINE OUT Port:** Connect to powered speakers or an amplifier for stereo analog audio output. This will output the audio from the Mic In on the connected receiver.

Note: This function is only available in unicast mode. The Mic In audio channel from the receiver is only active when an analog source is also connected to the Line In port on the transmitter.

- 11 **VGA IN Port:** Connect to VGA source equipment such as a PC or laptop.

6.2 Rear Panel

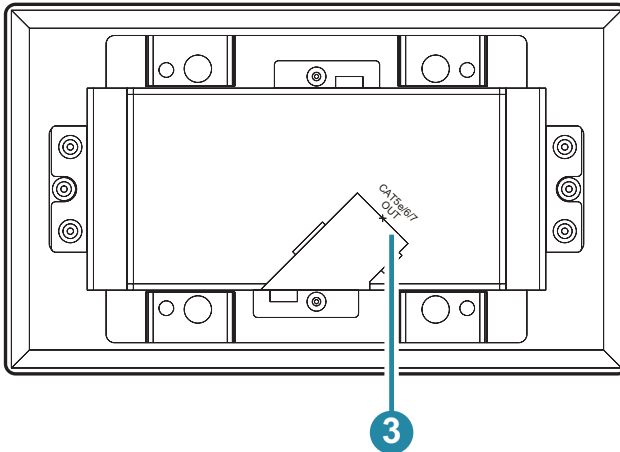

- 1 CAT5e/6/7 OUT Port:** Connect via a Gigabit Ethernet switch to compatible receiver(s) to transmit data, and to a PC/laptop to control the unit via WebGUI.

Note: This unit is powered directly by the PoE from the connected Gigabit Ethernet switch (802.3af minimum).

6.3 IR Cable Pinouts

IR Blaster Cable

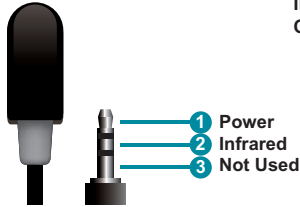

IR Extender Cable

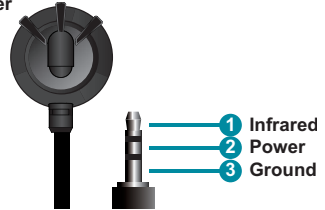

6.4 RS-232 Pinout and Defaults

Serial Port Default Settings	
Baud Rate	115200
Data Bits	8
Parity Bits	None
Stop Bits	1
Flow Control	None

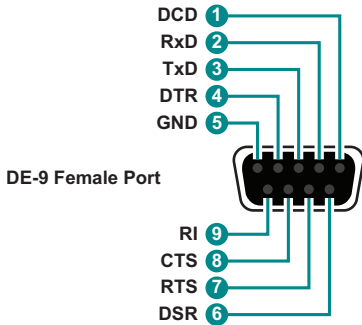

6.5 WebGUI Control

• Device Discovery

Please obtain the “Device Discovery” software from your authorized dealer and save it in a directory where you can easily find it.

Connect the unit and your PC/Laptop to the same active network and execute the “Device Discovery” software. Click on “Find Devices on Internet” and a list of devices connected to the local network will show up indicating their current IP address.

Note: The default network setting for this unit is “Auto IP”.

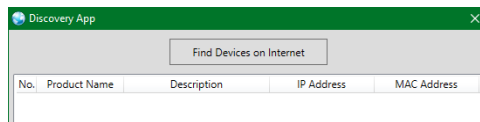

By clicking on one of the listed devices you will be presented with the network details of that particular device.

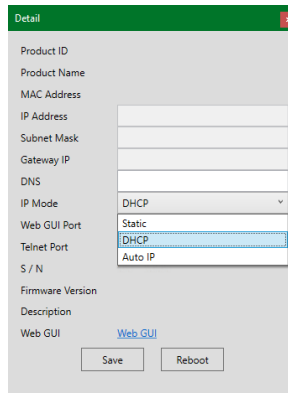

- 1) **IP Mode:** If you choose, you can alter the static IP network settings for the device, or switch the unit into DHCP mode to automatically obtain proper network settings from a local DHCP server. To switch to DHCP mode, please select DHCP from the IP mode drop-down, then click “Save” followed by “Reboot”.
- 2) **WebGUI Hotkey:** Once you are satisfied with the network settings, you may use them to connect via Telnet or WebGUI. The network information window provides a convenient link to launch the WebGUI directly.

- **WebGUI Overview**

All major functions of this unit, including status, streaming method, streaming channel selection, output resolution, video wall configuration, EDID management, Ethernet settings, and reset/firmware functions are controllable via multiple tabs in the WebGUI interface allowing for reasonably intuitive operation.

Each transmitter, receiver, or transceiver in the system is controlled by its own WebGUI interface which may be accessed by opening a standard web browser on a PC and typing in the IP address of the unit you wish to connect to. The easiest way to obtain each unit's IP address is to use the Discovery Tool software.

On a transceiver unit, the IP address of a unit can be obtained simply by checking the information screen within the OSD menu, accessed by pressing the menu button.

Alternatively, on stand-alone transmitters/receivers you can discover the IP address by checking the status OSD that is displayed when there is no live video source or no live link. Breaking the link is accomplished by pressing and holding the "LINK" button on the front of the currently associated receiver for 3 seconds (The LINK light will blink rapidly, then turn off). Once the link is broken, each connected receiver will output a 640×480 black screen with OSD text at the bottom identifying its own IP address (Local IP), as well as the IP address of the transmitter (Remote IP) that shares the same broadcasting channel with it (channel 0 by default). After obtaining the IP address information, press and hold the "LINK" button on the receiver again for 3 seconds to return the units to normal operation (The LINK light will light up solid yellow).

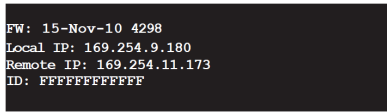

```
FW: 15-Nov-10 4298  
Local IP: 169.254.9.180  
Remote IP: 169.254.11.173  
ID: FFFFFFFFFF
```

After connecting to a unit's WebGUI, you will find a screen containing multiple tabs for each functionality area of the unit.

Note: AVoIP streaming uses a large amount of bandwidth (especially at higher resolutions) and a Gigabit Ethernet network switch with jumbo frame support and IGMP snooping is required. A professional managed switch with VLAN support is strongly recommended. Please note that most consumer-grade routers are not able to handle the high traffic rates generated by multicast mode, so using a router directly as your network switch is discouraged. It is strongly suggested to avoid mixing your regular network traffic with AVoIP streaming traffic and the AVoIP traffic should exist within a separate subnet, at the minimum.

6.5.1 System Tab

The System tab contains 4 windows that provide access to firmware version information, a firmware update interface, utilities for rebooting and resetting the unit, basic EDID management, Telnet command entry, and a variety of statistics and information about the operational state of the unit.

- 1) **Version Information Window:** This window displays detailed information about the current firmware version.

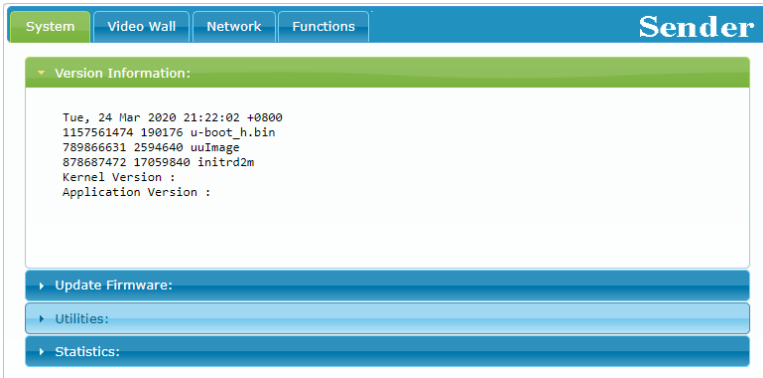

- 2) **Update Firmware Window:** Provides a way to update the transmitter's firmware. Click "Choose File" to select the firmware update file from the local PC (*.bin format). After selecting an appropriate file, click the "Upload" button to begin the update process.

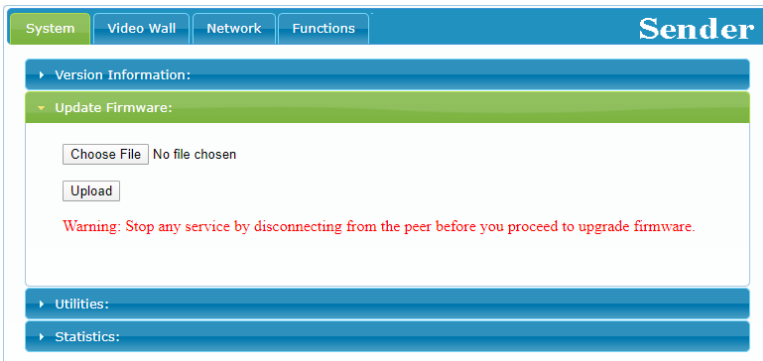

- 3) **Utilities Window:** The Utilities window allows users to reset the unit back to the factory defaults by clicking "Factory Default". The unit may be rebooted (without resetting settings) by pressing the "Reboot" button. If requested by technical support, you may also enable logging by clicking the "Log Message" checkbox.

If the EDID received from the primary receiver unit (selected via a checkbox on the preferred receiver in multicast mode) has compatibility issues with the connected source, a basic internal HDMI EDID (up to 4K30 w/audio) or basic VGA EDID can be selected. Please press “Apply” after making the selection.

Note: This EDID setting will be reset if the unit is rebooted.

Finally, individual Telnet commands may be sent to the unit by using the “Console API Command” text entry field and pressing “Apply”. Any responses from the unit will be displayed in the “Output” field.

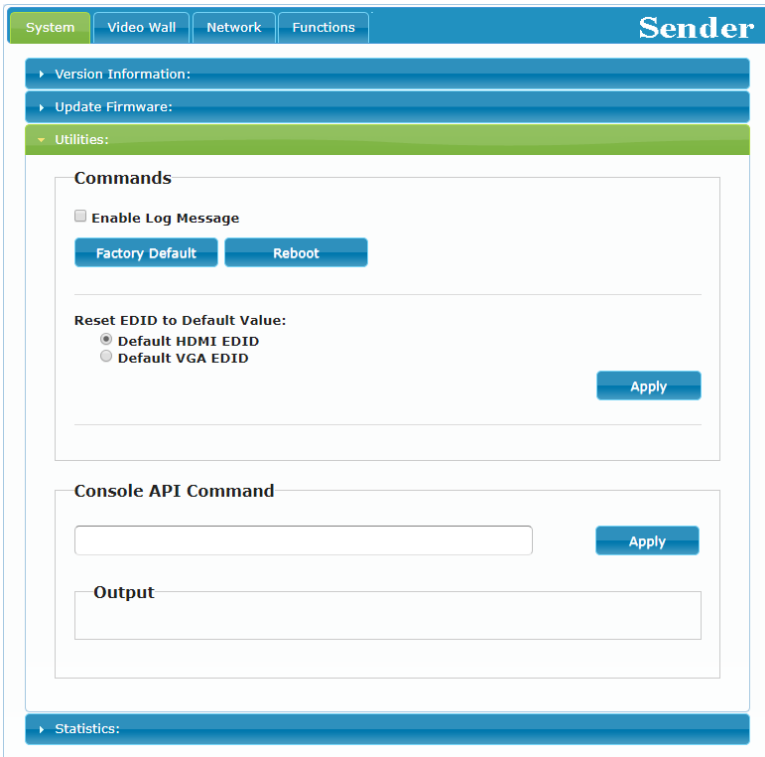

The screenshot shows the 'Sender' web interface with a navigation bar at the top containing 'System', 'Video Wall', 'Network', and 'Functions'. The main content area is titled 'Sender' and has a blue header. Below the header, there are several expandable sections: 'Version Information:', 'Update Firmware:', and 'Utilities:'. The 'Utilities:' section is expanded and contains a 'Commands' section. In the 'Commands' section, there is a checkbox for 'Enable Log Message'. Below it are two buttons: 'Factory Default' and 'Reboot'. Further down, there is a section titled 'Reset EDID to Default Value:' with two radio button options: 'Default HDMI EDID' (which is selected) and 'Default VGA EDID'. An 'Apply' button is located to the right of these options. Below the 'Commands' section is a 'Console API Command' section with a text input field and an 'Apply' button. At the bottom of the 'Console API Command' section is an 'Output' text area. At the very bottom of the interface, there is a 'Statistics:' section which is currently collapsed.

- 4) **Statistics Window:** The Statistics window shows all available information about the operational status of the unit, including the current host name, serial number, Ethernet information, MAC address, unicast/multicast mode, and link status and mode.

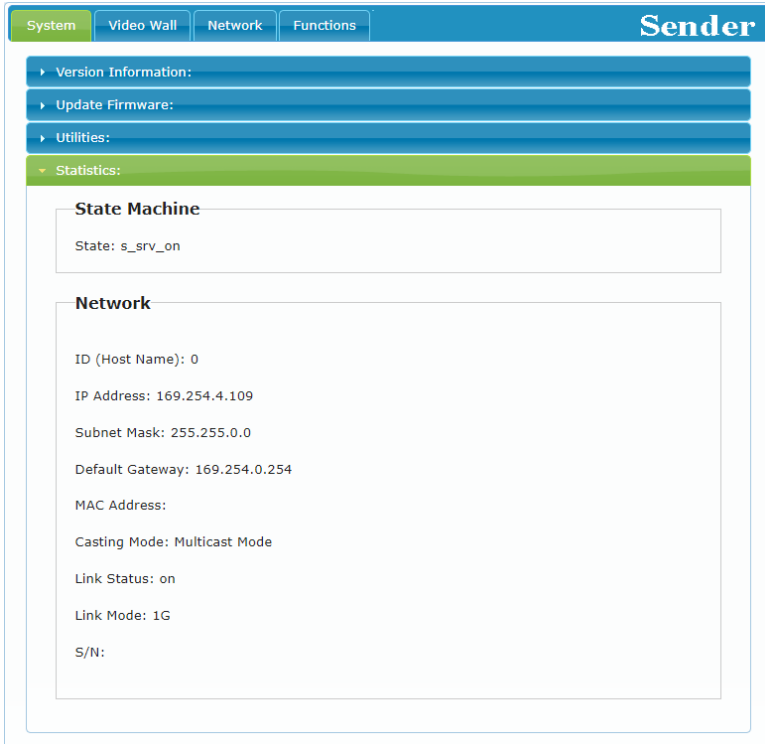

The screenshot displays the 'Sender' web interface. At the top, there is a navigation bar with tabs for 'System', 'Video Wall', 'Network', and 'Functions'. The 'System' tab is currently selected. Below the navigation bar, there are several expandable sections: 'Version Information', 'Update Firmware', 'Utilities', and 'Statistics'. The 'Statistics' section is expanded, showing two sub-sections: 'State Machine' and 'Network'. The 'State Machine' section displays 'State: s_srv_on'. The 'Network' section displays the following information: ID (Host Name): 0, IP Address: 169.254.4.109, Subnet Mask: 255.255.0.0, Default Gateway: 169.254.0.254, MAC Address: (blank), Casting Mode: Multicast Mode, Link Status: on, Link Mode: 1G, and S/N: (blank).

6.5.2 Video Wall Tab

The Video Wall tab allows user to design, edit and manipulate a video wall system created using multiple receiver units connected to identical displays. The bezel and video size of the displays being used, as well as the horizontal and vertical monitor count, is defined here. Video stretch and rotation can also be controlled on this tab. Receivers in the video wall's group (all receivers sharing the same channel) can be controlled by any other unit within the same group.

Note: While the Video Wall tab is accessible on transmitters, video wall settings only have an effect on receivers.

When saving changes on the Video Wall tab, remember to select the appropriate "Apply To:" target unit before pressing the "Apply" button. Select the IP address of the receiver (Client) you want to apply changes to from the "Apply To:" drop down.

Note: While it is possible to create small video walls using unicast mode, in order to more efficiently use the available network bandwidth, it is strongly recommended to only use multicast mode when creating video walls.

- 1) Bezel and Gap Compensation:** This section of the Video Wall tab is used to define the physical dimensions of each display being used in the video wall. Accurate measurements are needed of the monitor's outer frame (OW, OH) and the video screen (VW, VH). The measurements may be made using any unit format (inches, mm, cm, etc.) as long as ALL measurements in the same wall are made using the exact same units and the numbers are integers.

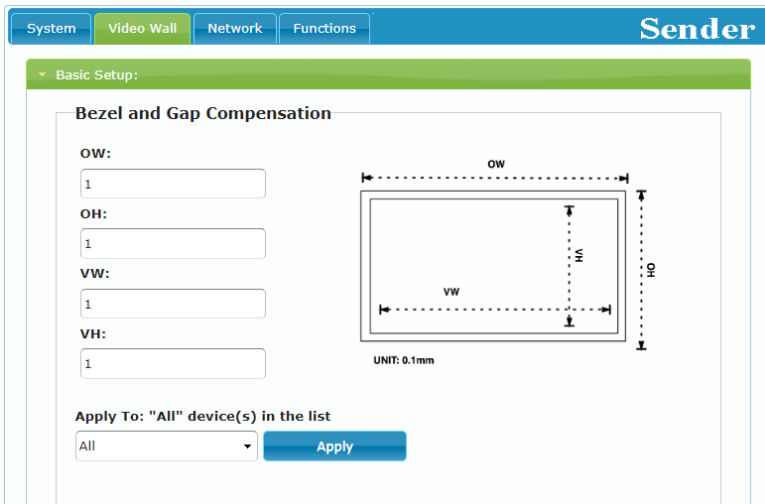

System Video Wall Network Functions **Sender**

Basic Setup:

Bezel and Gap Compensation

OW:

OH:

VW:

VH:

UNIT: 0.1mm

Apply To: "All" device(s) in the list

All

- **OW (Outer Width):** This is the horizontal measurement of the display's outer case.
- **OH (Outer Height):** This is the vertical measurement of the display's outer case.
- **VW (Video Width):** This is the horizontal measurement of the display's video screen.
- **VH (Video Height):** This is the vertical measurement of the display's video screen.

Note: Typically all monitors in a video wall are identical and have the same dimensions, but it is possible to use differently sized displays as long as the same measurement units are used to measure each display and the displays are still arranged in a normal rectangular layout with corners meeting at the same place.

- **Apply To:** Select which unit(s) to send updated settings to when “Apply” is pressed.
 - Selecting “All” will direct updates to the video wall bezel settings of all units in the current video wall group.
 - Selecting an IP address from the “Clients” list will direct updates to the video wall settings of the receiver with that IP address.

2) **Wall Size and Position Layout:** This section of the Video Wall tab is used to define the number of displays used in the video wall as well as the location of the specific display within the video wall. A typical video wall consists of an equal number of horizontal and vertical monitors (for example: 2×2 or 3×3), however it is possible to create video walls using this system with a wider variety of dimensions as long as the end result is still a rectangle (for example: 5×1 or 2×3). Both horizontal and vertical dimensions are limited to a maximum of 16 displays.

Wall Size and Position Layout

Vertical Monitor Count:

Horizontal Monitor Count:

Row Position:

Column Position:

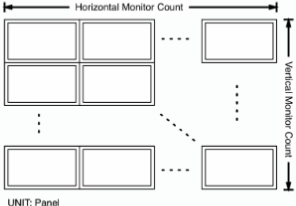

- **Vertical Monitor Count:** Define the number of displays in the video wall, measured vertically. (Maximum is 16 displays)
 - **Horizontal Monitor Count:** Define the number of displays in the video wall, measured horizontally. (Maximum is 16 displays)
 - **Row Position:** Set the vertical location of the currently controlled display. (Counts top to bottom, from 0 to 15)
 - **Column Position:** Set the horizontal location of the currently controlled display. (Counts left to right, from 0 to 15)
- 3) **Preferences:** This section of the Video Wall tab provides additional controls over how the source video is displayed on the video wall as well as providing a drop down to determine which receiver to apply changed settings to and an option to show the OSD.

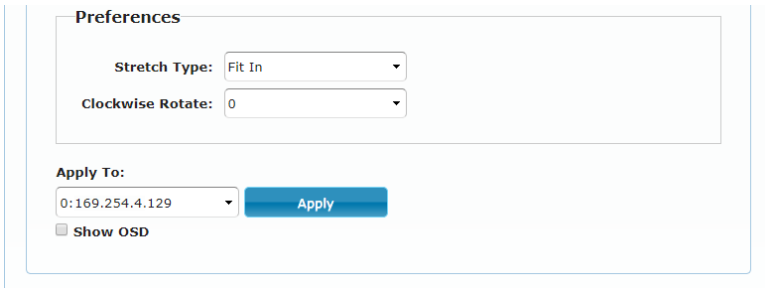

The screenshot shows a 'Preferences' window with the following elements:

- Stretch Type:** A dropdown menu currently set to 'Fit In'.
- Clockwise Rotate:** A dropdown menu currently set to '0'.
- Apply To:** A dropdown menu currently set to '0:169.254.4.129'.
- Apply:** A blue button to apply the settings.
- Show OSD:** A checkbox that is currently unchecked.

- **Stretch Type:** Set the video stretch method.
 - Selecting “Fit In” will expand the video to exactly fit the dimensions of the video wall regardless of the source’s original aspect ratio.
 - Selecting “Stretch Out” will zoom the video until the video wall is filled in all 4 dimensions while maintaining the aspect ratio of the original source.
- **Clockwise Rotate:** Set the rotation of the video output to 0, 180 or 270 degrees.
- **Apply To:** Select which unit(s) to send updated settings to when “Apply” is pressed.
 - Selecting an IP address from the “Clients” list will direct updates to the video wall settings of the receiver with that IP address.
- **Show OSD:** Enables or disables the OSD display of each receivers’ ID within the Video Wall group.

Note: When setting up a new video wall, or changing the configuration of an existing one, remember to update the configuration of each receiver in the system.

6.5.3 Network Tab

The Network tab provides control over the transmitter’s broadcast channel, IP configuration, and network broadcast mode. Changes made to the network settings will require a reboot of the unit. After clicking on “Apply” please follow the reboot instructions in the WebGUI.

Note: If the IP address is changed then the IP address required for WebGUI access will also change accordingly. If the new address is assigned via “Auto IP” or “DHCP” it will be necessary to obtain the newly assigned IP address by using the Device Discovery Tool, or by checking the OSD info screen when there is no live video connection.

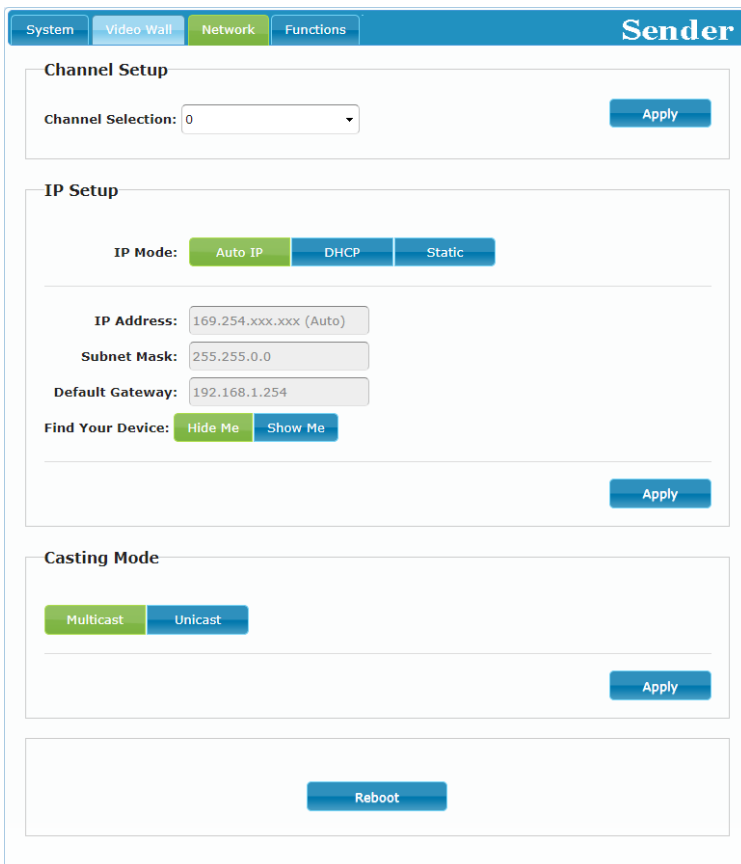

- 1) **Channel Setup:** Use the dropdown to select the broadcast channel for the transmitter. All receivers on the local network will receive video,

audio, and data content from the transmitter that is set to the same channel. The available channel range is from 0 to 255.

Note: Every transmitter within the same local network MUST be assigned a different broadcast channel in order to avoid transmission conflicts.

- 2) **IP Setup:** This section allows for configuration of the IP acquisition mode and Ethernet settings of the unit. It also provides an easy way to find the physical unit when installed with many other similar units.

■ **IP Mode & Settings:** The IP mode may be switched between “Auto IP”, “DHCP” or “Static IP”. When the unit is set to Auto IP mode it will automatically assign itself an APIPA address from the 169.254.xxx.xxx range. When the unit is set to DHCP mode it will attempt to automatically obtain an IP address from a DHCP server. When the IP mode is set to static IP, you can manually set the IP address, netmask and gateway address. Click the “Apply” button to save changes made to the IP Mode or Configuration.

Note: The default network setting for this unit is “Auto IP”.

■ **Find Your Device:** Selecting “Show Me” will cause the unit to immediately begin flashing the LEDs on the front of the unit to make it easy to find. Selecting “Hide Me” returns the LEDs to their normal behavior. This setting is useful when troubleshooting an installation with a large number of units in a rack.

- 3) **Casting Mode:** Allows for the selection of the networking mode used by the transmitter. Click the “Apply” button to save changes made to the broadcasting mode.

Note: Receivers must be set to the same mode as the transmitter in order to receive video and data content.

■ **Multicast:** This mode sends a single video stream that can be viewed simultaneously by multiple receivers without increasing bandwidth usage. This mode is ideal for video wall or matrixing scenarios. Multicast mode requires a network switch with IGMP snooping enabled.

Note: The 3 port network switch built into the dedicated receiver unit supports IGMP snooping and may be used to distribute a multicast stream.

■ **Unicast:** This mode uses a discrete video stream between the transmitter and every connected receiver and is ideal for simple, point-to-point, streaming setups. This mode uses considerably more bandwidth than Multicast mode when multiple receivers are being used, however it does not require a network switch that supports IGMP snooping.

6.5.4 Functions Tab

The Functions tab provides control over the unit's AV source management, and streaming bandwidth/quality settings, as well as defining how USB and serial signals are handled. Changes made to these settings typically require a reboot of the unit. After clicking on "Apply" please follow the reboot instructions in the WebGUI, if necessary.

- 1) **Video over IP:** This section allows control over the streaming bit rate and quality.

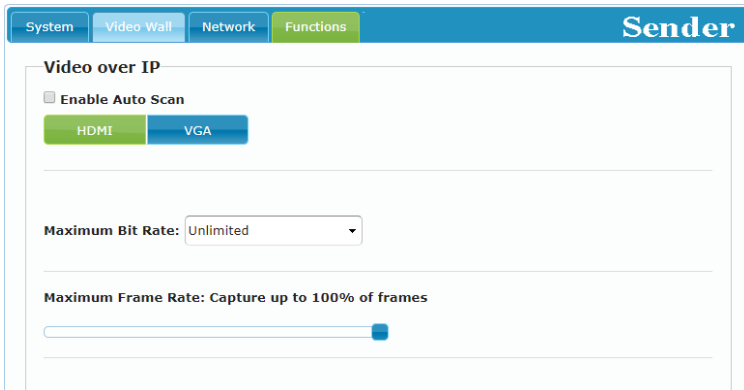

The screenshot shows the 'Functions' tab in the 'Sender' web interface. Under the 'Video over IP' section, there is a checkbox for 'Enable Auto Scan'. Below it are two buttons for source selection: 'HDMI' (highlighted in green) and 'VGA'. Further down, there is a 'Maximum Bit Rate' dropdown menu currently set to 'Unlimited'. At the bottom, there is a 'Maximum Frame Rate' slider set to 'Capture up to 100% of frames'.

- **Source Selection:** Select the preferred input source, HDMI or VGA or enable the auto scan function of the unit by checking the "Enable Auto Scan" checkbox.

Note: Once searching for a new source begins, the input will automatically switch back and forth until a valid video source is detected.

- **Maximum Bit Rate:** Set the maximum bit rate that can be used by the output video stream. Available options are: Unlimited, 400 Mbps, 200 Mbps, 100 Mbps, 50 Mbps. Selecting "Unlimited" will use up to the maximum available bandwidth in order to maintain a full framerate video stream.

Note: While it is generally suggested to select "Unlimited" when streaming 4K video sources, the amount of bandwidth required can be very large and will limit the number of concurrent video streams.

- **Maximum Framerate:** Adjusting this slider will set the percentage of frames from the source video to encode (2–100%). This is ideal for reducing the bandwidth requirements of high-resolution, but limited motion, sources such as slide presentations or information screens.

Note: If the framerate is lowered too far with motion video sources, the video will become noticeably choppy.

- 2) **Audio over IP:** The audio source to embed with the current video source in the outbound AVoIP stream is selected here. Selecting “HDMI” will embed the current HDMI video’s audio source, selecting “Line In” will embed the Line In audio source.



Audio over IP

HDMI Line In

Note: This setting is stored independently for each video input. By default HDMI audio is paired with HDMI video and Line In audio is paired with VGA video. When the Video over IP Auto Scan function has been enabled this section will be greyed out and audio will follow the default configuration.

- 3) **USB over IP:** This section provides controls for the USB over IP extension functionality, including enabling various USB compatibility settings.

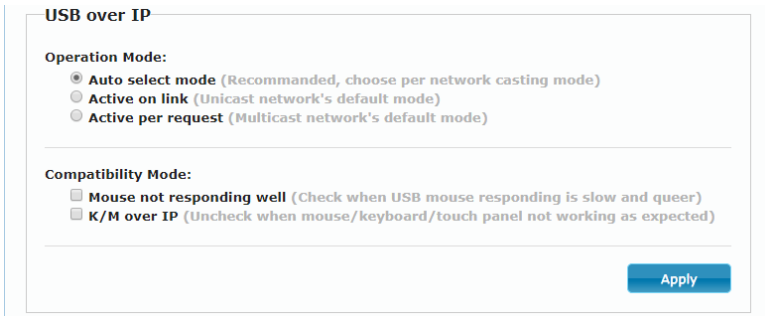

USB over IP

Operation Mode:

- Auto select mode (Recommended, choose per network casting mode)
- Active on link (Unicast network's default mode)
- Active per request (Multicast network's default mode)

Compatibility Mode:

- Mouse not responding well (Check when USB mouse responding is slow and queer)
- K/M over IP (Uncheck when mouse/keyboard/touch panel not working as expected)

Apply

- **Operation Mode:** Sets the USB extension mode. Available options are Auto, Active on link (Unicast optimized), and Active per request (Multicast optimized). Auto mode is set by default and will automatically select the correct mode depending on the broadcast mode of the unit.
- **Compatibility Mode:** These troubleshooting options enable specialized optimizations to solve issues when a mouse or touch panel is not responding properly. They should normally be left unchecked.

- 5) **Serial over IP:** This section provides controls for the serial over IP extension functionality, including setting the RS-232 data configuration.

Serial over IP

Baudrate: 115200 ▼

Data bits: 8 ▼

Parity: None ▼

Stop bits: 1 ▼

Apply

Reboot

- **Serial Settings:** Set the desired baud rate, data bits, parity, and stop bit for the RS-232 signal to extend.

Note: The transmitter and receiver must have the same serial settings.

- 5) **Reboot:** Pressing this button will force the unit to reboot.

6.6 Telnet Control

Before attempting to use Telnet control, please ensure that both the unit and the PC are connected to the same active networks.

Start your preferred Telnet/Console client, or use the built in client provided by most modern computer operating systems. After starting the client, connect by using the current IP address of the unit and port 23 (if the communication port number used by the unit has not been changed previously). This will connect us to the unit we wish to control and commands may now be entered directly.

Note 1: If the IP address of the unit is changed then the IP address required for Telnet access will also change accordingly.

Note 2: By default the unit is set to "Auto IP" mode. The current IP address can be obtained by using the Device Discovery Tool, or by checking the OSD info screen when there is no live video connection. The default communication port is 23.

6.7 Telnet Commands

COMMAND
Description and Parameters
help ↵ Show the full command list.
help N1 ↵ Show help details about the specified command. N1 = {Command name}
get_hardware_version ↵ Show the unit's current hardware version.
get_firmware_version ↵ Show the unit's current firmware version.
set_device_name N1 ↵ Set the name of the unit. N1 = {Name} [29 characters max, ASCII only]

COMMAND							
Description and Parameters							
get_device_name ↵	Show the unit's current device name.						
factory_reset N1 ↵	<p>Perform a factory reset on the unit and select the IP mode after the reset completes.</p> <p>Available values for N1:</p> <table> <tr> <td>0</td> <td>[Reset into Static IP mode]</td> </tr> <tr> <td>1</td> <td>[Reset into Auto IP mode]</td> </tr> </table>	0	[Reset into Static IP mode]	1	[Reset into Auto IP mode]		
0	[Reset into Static IP mode]						
1	[Reset into Auto IP mode]						
reboot ↵	Reboot the unit.						
get_ipconfig ↵	Show the unit's current IP configuration.						
set_ip_mode N1 ↵	<p>Set the unit's IP configuration mode.</p> <p>Available values for N1:</p> <table> <tr> <td>0</td> <td>[Static IP mode]</td> </tr> <tr> <td>1</td> <td>[DHCP mode]</td> </tr> <tr> <td>2</td> <td>[Auto IP mode]</td> </tr> </table>	0	[Static IP mode]	1	[DHCP mode]	2	[Auto IP mode]
0	[Static IP mode]						
1	[DHCP mode]						
2	[Auto IP mode]						
get_ip_mode ↵	Show the unit's current IP configuration mode.						
set_ip_address N1 ↵	<p>Set the unit's static IP address.</p> <p>N1 = X.X.X.X [X = 0~255, IP address]</p>						
get_ip_address ↵	Show the unit's current IP address.						
set_netmask N1 ↵	<p>Set the unit's Ethernet netmask.</p> <p>N1 = X.X.X.X [X = 0~255, Netmask]</p>						

COMMAND	
Description and Parameters	
get_netmask ↵	Show the unit's current Ethernet netmask.
set_gateway N1 ↵	Set the unit's IP gateway address. N1 = X.X.X.X [X = 0~255, Gateway address]
get_gateway ↵	Show the unit's current gateway address.
set_net_mode N1	Set the unit's network broadcast mode. Available values for N1 : 0 [Unicast mode] 1 [Multicast mode]
get_net_mode ↵	Show the unit's current network broadcast mode.
set_jumbo_mtu N1 ↵	Enable/disable the unit's jumbo frame MTU. Available values for N1 : 0 [Disabled] 1 [Enabled]
get_jumbo_mtu ↵	Show the unit's current jumbo frame MTU state.
video_source_hdmi ↵	Select HDMI as the video input source.
video_source_vga ↵	Select VGA as the video input source.

COMMAND					
Description and Parameters					
set_auto_scan N1 ↵	<p>Enable or disable the unit's auto source scanning functionality.</p> <p>Available values for N1:</p> <table> <tr> <td>0</td> <td>[Disable auto scan]</td> </tr> <tr> <td>1</td> <td>[Enable auto scan]</td> </tr> </table>	0	[Disable auto scan]	1	[Enable auto scan]
0	[Disable auto scan]				
1	[Enable auto scan]				
get_auto_scan ↵	<p>Show the current state of the auto scan setting.</p>				
a N1 ↵	<p>Set the transmitter's local audio streaming source to use with the current video input.</p> <p>Available values for N1:</p> <table> <tr> <td>D</td> <td>[Digital audio source]</td> </tr> <tr> <td>A</td> <td>[Analog audio source]</td> </tr> </table>	D	[Digital audio source]	A	[Analog audio source]
D	[Digital audio source]				
A	[Analog audio source]				
get_a ↵	<p>Show the transmitter's current audio streaming source selection.</p>				
set_showme N1 ↵	<p>Enable or disable Hello Mode. Hello Mode will cause the unit's LEDs to blink and visually identify the unit.</p> <p>Available values for N1:</p> <table> <tr> <td>ON</td> <td>[Enabled]</td> </tr> <tr> <td>OFF</td> <td>[Disabled]</td> </tr> </table>	ON	[Enabled]	OFF	[Disabled]
ON	[Enabled]				
OFF	[Disabled]				
get_showme ↵	<p>Show the current Hello Mode state.</p>				
set_tx_channel N1 ↵	<p>Set the AVoIP transmission channel.</p> <table> <tr> <td>N1 = 0~255</td> <td>[Transmission channel]</td> </tr> </table>	N1 = 0~255	[Transmission channel]		
N1 = 0~255	[Transmission channel]				
get_tx_channel ↵	<p>Show the current AVoIP transmission channel.</p>				

COMMAND	
Description and Parameters	
set_quality N1 ←	
Set the picture quality mode.	
Available values for N1 :	
0	[Graphic mode]
1	[Video mode]
get_quality ←	
Show the current picture quality mode.	
set_hdcp_allow N1 ←	
Enable/disable HDCP encrypted source support.	
Available values for N1 :	
0	[Disabled]
1	[Enabled]
get_hdcp ←	
Show the current HDCP support state.	
set_bandwidth N1 ←	
Set the broadcast stream bandwidth maximum.	
Available values for N1 :	
0	[50 Mbps]
1	[100 Mbps]
2	[200 Mbps]
3	[400 Mbps]
4	[Unlimited]
set_frame_rate N1 ←	
Set the frame rate percentage (in 1/60 steps) to use when encoding the source video.	
Available values for N1 :	
0	[Frame rate reduction disabled]
1~60	[Frame rate percentage in 1/60 steps]

COMMAND

Description and Parameters

set_vw_osd N1 {N2}←

Enable/disable the video wall OSD to display the receiver's ID number on the specified receiver's display.

Available values for **N1**:

0 [Disable OSD]

1 [Enable OSD]

N2 = 0~255 [Target receiver ID {Optional}]

*Note: Omitting **N2** makes the setting global to all receivers.*

set_vw_layout N1 N2 {N3}←

Set the video wall total horizontal and vertical display count for the specified receiver.

N1 = 1~16 [Horizontal display count]

N2 = 1~16 [Vertical display count]

N3 = 0~255 [Target receiver ID {Optional}]

*Note: The target receiver ID number can be obtained by turning on the Video Wall OSD. Omitting **N3** makes the settings global to all Receivers.*

set_vw_pos N1 N2 {N3}←

Set the display's position within the video wall. (Cannot exceed the video wall's horizontal and vertical display count.)

N1 = 0~15 [Row]

N2 = 0~15 [Column]

N3 = 0~255 [Target receiver ID {Optional}]

*Note: The target receiver ID number can be obtained by turning on the Video Wall OSD. Omitting **N3** makes the settings global to all receivers.*

COMMAND

Description and Parameters

set_vw_bc N1 N2 N3 N4 {N5}←

Set the video wall display bezel compensation values for the specified receiver.

N1 = 0~99999	[Video width]
N2 = 0~99999	[Total display width]
N3 = 0~99999	[Video height]
N4 = 0~99999	[Total display height]
N5 = 0~255	[Target receiver ID {Optional}]

*Note: The target receiver ID number can be obtained by turning on the Video Wall OSD. Omitting **N5** makes the settings global to all receivers.*

set_vw_hscale N1 {N2}←

Set the video wall display horizontal zoom amount for the specified receiver.

N1 = 0~99999	[Zoom amount in 1 pixel units]
N2 = 0~255	[Target receiver ID {Optional}]

*Note: The target receiver ID number can be obtained by turning on the Video Wall OSD. Omitting **N2** makes the setting global to all receivers.*

set_vw_vscale N1 {N2}←

Set the video wall display vertical zoom amount for the specified receiver.

N1 = 0~99999	[Zoom amount in 1 pixel units]
N2 = 0~255	[Target receiver ID {Optional}]

*Note: The target receiver ID number can be obtained by turning on the Video Wall OSD. Omitting **N2** makes the setting global to all receivers.*

COMMAND

Description and Parameters

set_vw_shift N1 N2 {N3}↵

Set the video wall display output shift for the specified receiver.

Available values for **N1**:

U	[Shift up]
D	[Shift down]
L	[Shift left]
R	[Shift right]

N2 = 0~80000 [Pixel shift amount in increments of 8.]

N3 = 0~255 [Target receiver ID {Optional}]

*Note: The target receiver ID number can be obtained by turning on the Video Wall OSD. Omitting **N3** makes the setting global to all receivers.*

set_usb_mouse N1↵

Enable/disable USB mouse compatibility support.

Available values for **N1**:

0	[High resolution mode]
1	[Compatibility mode]

get_usb_mouse↵

Show the current USB mouse compatibility support state.

set_serial_baud N1↵

Set the serial baud rate.

Available values for **N1**:

0	[300 baud]
1	[600 baud]
2	[1200 baud]
3	[2400 baud]
4	[4800 baud]
5	[9600 baud]
6	[19200 baud]
7	[38400 baud]
8	[57600 baud]
9	[115200 baud]

get_serial_baud↵

Show the current serial baud rate.

COMMAND	
Description and Parameters	
set_serial_bits N1 ↵	
Set the number of serial data bits.	
Available values for N1 :	
0	[5 bits]
1	[6 bits]
2	[7 bits]
3	[8 bits]
get_serial_bits ↵	
Show the current number of serial data bits.	
set_serial_parity N1 ↵	
Set the serial parity bit.	
Available values for N1 :	
0	[None]
1	[Odd]
2	[Even]
get_serial_parity ↵	
Show the current serial parity bit value.	
set_serial_stop N1 ↵	
Set the serial stop bits.	
Available values for N1 :	
0	[1 bit]
1	[2 bits]
get_serial_stop ↵	
Show the current number of serial stop bits.	

Note: Commands will not be executed unless followed by a carriage return. Commands are not case-sensitive.

7. CONNECTION DIAGRAM

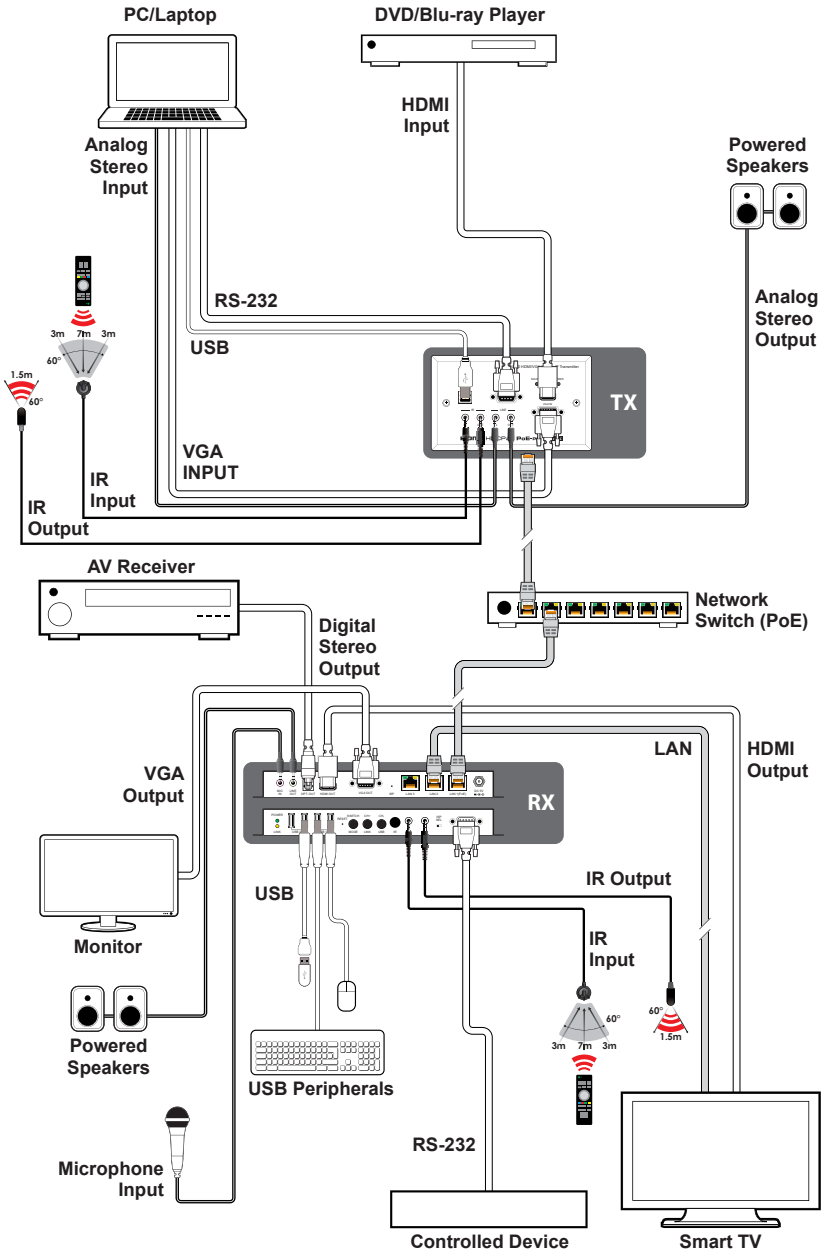

8. SPECIFICATIONS

8.1 Technical Specifications

HDMI Bandwidth	10.2Gbps
VGA Bandwidth	165MHz
Ethernet Bandwidth	1Gbps
Input Ports	1×HDMI (Type-A) 1×VGA (HD-15) 1×Stereo Audio (3.5mm)
Output Ports	1×Stereo Audio (3.5mm)
Pass-through Ports	1×IR Extender (3.5mm) 1×IR Blaster (3.5mm) 1×RS-232 (DE-9) 1×USB 2.0 (Type-B)
Bi-directional/Control Port	1×LAN (RJ-45)
IR Frequency	30 ~ 50kHz (30 ~ 60kHz under ideal conditions)
Baud Rate	Up to 115200
Power Supply	PoE (802.3af minimum)
ESD Protection (HBM)	±8kV (Air Discharge) ±4kV (Contact Discharge)
Dimensions (W×H×D)	152mm×81mm×42mm [Case Only] 152mm×81mm×53mm [All Inclusive]
Weight	246g
Chassis Material	Metal (Steel)
Chassis Color	White
Operating Temperature	0°C – 40°C/32°F – 104°F
Storage Temperature	-20°C – 60°C/-4°F – 140°F
Relative Humidity	20 – 90% RH (Non-condensing)
Power Consumption	7.5W

8.2 Video Specifications

Supported Resolutions (Hz)	Input		Output
	HDMI	VGA	GbE
720×400p@70/85	✓	✗	✓
640×480p@60/72/75/85	✓	✓	✓
720×480i@60	✓	✗	✓
720×480p@60	✓	✓	✓
720×576i@50	✓	✗	✓
720×576p@50	✓	✓	✓
800×600p@56/60/72/75/85	✓	✓	✓
848×480p@60	✓	✓	✓
1024×768p@60/70/75/85	✓	✓	✓
1152×864p@75	✓	✓	✓
1280×720p@50/60	✓	✓	✓
1280×768p@60/75/85	✓	✓	✓
1280×800p@60/75/85	✓	✓	✓
1280×960p@60/85	✓	✓	✓
1280×1024p@60/75/85	✓	✓	✓
1360×768p@60	✓	✓	✓
1366×768p@60	✓	✓	✓
1400×1050p@60	✓	✓	✓
1440×900p@60/75	✓	✓	✓
1600×900p@60RB	✓	✓	✓
1600×1200p@60	✓	✓	✓
1680×1050p@60	✓	✓	✓
1920×1080i@50/60	✓	✗	✓
1920×1080p@24/25/30	✓	✓	✓
1920×1080p@50/60	✓	✓	✓
1920×1200p@60RB	✓	✓	✓

Supported Resolutions (Hz)	Input		Output
	HDMI	VGA	GbE
2560×1440p@60RB	x	x	x
2560×1600p@60RB	x	x	x
2048×1080p@24/25/30	x	x	x
2048×1080p@50/60	x	x	x
3840×2160p@24/25/30	✓	x	✓
3840×2160p@50/60 (4:2:0)	✓	x	x
3840×2160p@24, HDR10	x	x	x
3840×2160p@50/60 (4:2:0), HDR10	x	x	x
3840×2160p@50/60	x	x	x
4096×2160p@24/25/30	✓	x	✓
4096×2160p@50/60 (4:2:0)	✓	x	x
4096×2160p@24, HDR10	x	x	x
4096×2160p@50/60 (4:2:0), HDR10	x	x	x
4096×2160p@50/60	x	x	x

Note: 4K@50/60Hz (4:2:0) video sources will automatically be converted to 4K@25/30Hz (RGB) for AVoIP transmission.

8.3 Audio Specifications

8.3.1 DIGITAL AUDIO

HDMI Input	
LPCM	
Max Channels	8 Channels
Sampling Rate (kHz)	32, 44.1, 48, 88.2, 96, 176.4, 192
Bitstream	
Supported Formats	Standard
AVoIP Transmission	
LPCM	
Max Channels	8 Channels
Sampling Rate (kHz)	32, 44.1, 48, 88.2, 96, 176.4, 192
Bitstream	
Supported Formats	Standard

8.3.2 Analog Audio

Analog Input	
Max Audio Level	2Vrms
Impedance	48.2kΩ
Type	Unbalanced
Analog Output	
Max Audio Level	2Vrms
THD+N	< -86dB@0dBFS 1kHz (A-wt)
SNR	> 96dB@0dBFS
Frequency Response	< ±46dB@20Hz~20kHz
Crosstalk	< -60dB@10kHz
Impedance	470Ω
Type	Unbalanced

8.3.3 AVoIP Audio Availability

Unicast Data Transmission Mode:

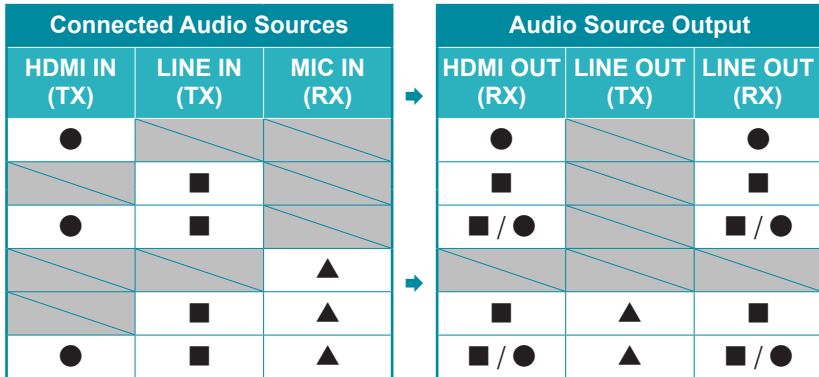

Multicast Data Transmission Mode:

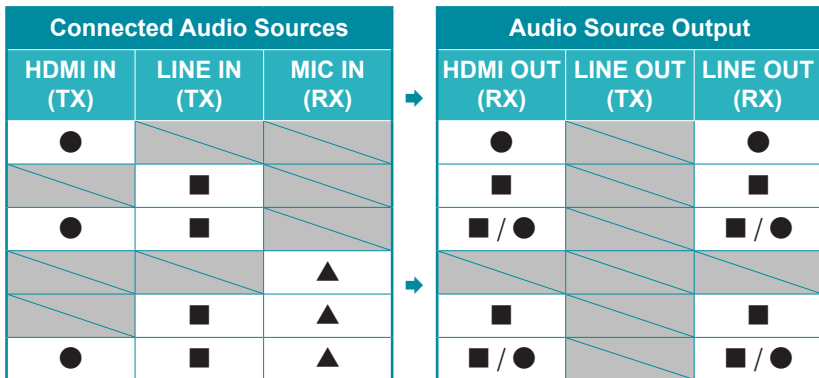

Legend:

- = HDMI audio source.
- = Line In (Transmitter) audio source.
- ▲ = Line In (Receiver) audio source.

8.4 Cable Specifications

Cable Length	1080p		4K30	4K60
	8-bit	12-bit	(4:4:4) 8-bit	(4:4:4) 8-bit
High Speed HDMI Cable				
HDMI Input	15m	10m	5m	x
VGA Cable				
VGA Input	2m		x	
Ethernet Cable				
Cat.5e/6	100m			x
Cat.6A/7	100m			x

Bandwidth Category Examples:

- **1080p (FHD Video)**
 - Up to 1080p@60Hz, 12-bit color
 - Data rates lower than 5.3Gbps or below 225MHz TMDS clock
- **4K30 (4K UHD Video)**
 - 4K@24/25/30Hz & 4K@50/60Hz (4:2:0), 8-bit color
 - Data rates higher than 5.3Gbps or above 225MHz TMDS clock but below 10.2Gbps
- **4K60 (4K UHD⁺ Video)**
 - 4K@50/60Hz (4:4:4, 8-bit)
 - 4K@50/60Hz (4:2:0, 10-bit HDR)
 - Data rates higher than 10.2Gbps

9. ACRONYMS

ACRONYM	COMPLETE TERM
ADC	Analog-to-Digital Converter
ASCII	American Standard Code for Information Interchange
AVoIP	Audio/Video over IP
Cat.5e	Enhanced Category 5 cable
Cat.6	Category 6 cable
Cat.6A	Augmented Category 6 cable
Cat.7	Category 7 cable
CLI	Command-Line Interface
DAC	Digital-to-Analog Converter
dB	Decibel
DHCP	Dynamic Host Configuration Protocol
DVI	Digital Visual Interface
EDID	Extended Display Identification Data
GbE	Gigabit Ethernet
Gbps	Gigabits per second
GUI	Graphical User Interface
HDCP	High-bandwidth Digital Content Protection
HDMI	High-Definition Multimedia Interface
HDR	High Dynamic Range
IGMP	Internet Group Management Protocol
IP	Internet Protocol
IR	Infrared
kHz	Kilohertz
KVM	Keyboard/Video/Mouse
LAN	Local Area Network
LED	Light-Emitting Diode
LPCM	Linear Pulse-Code Modulation
MAC	Media Access Control

ACRONYM	COMPLETE TERM
MJPEG	Motion JPEG
MHz	Megahertz
OSD	On-Screen Display
PoE	Power over Ethernet
SNR	Signal-to-Noise Ratio
TCP	Transmission Control Protocol
THD+N	Total Harmonic Distortion plus Noise
4K UHD	4K Ultra-High-Definition (10.2Gbps max)
4K UHD⁺	4K Ultra-High-Definition (18Gbps max)
UHDTV	Ultra-High-Definition Television
USB	Universal Serial Bus
VGA	Video Graphics Array
VLAN	Virtual LAN
VoIP	Video over IP
WUXGA (RB)	Widescreen Ultra Extended Graphics Array (Reduced Blanking)
XGA	Extended Graphics Array
Ω	Ohm



CYPRESS TECHNOLOGY CO., LTD.
www.cypress.com.tw
