



# CH-2540RX

UHD+ HDMI over HDBaseT Receiver with Amplifier



Operation Manual



The terms HDMI, HDMI High-Definition Multimedia Interface, and the HDMI Logo are trademarks or registered trademarks of HDMI licensing Administrator, Inc.

## DISCLAIMERS

The information in this manual has been carefully checked and is believed to be accurate. Cypress Technology assumes no responsibility for any infringements of patents or other rights of third parties which may result from its use.

Cypress Technology assumes no responsibility for any inaccuracies that may be contained in this document. Cypress also makes no commitment to update or to keep current the information contained in this document.

Cypress Technology reserves the right to make improvements to this document and/or product at any time and without notice.

## COPYRIGHT NOTICE

No part of this document may be reproduced, transmitted, transcribed, stored in a retrieval system, or any of its part translated into any language or computer file, in any form or by any means—electronic, mechanical, magnetic, optical, chemical, manual, or otherwise—without express written permission and consent from Cypress Technology.

© Copyright 2018 by Cypress Technology.

All Rights Reserved.

## TRADEMARK ACKNOWLEDGMENTS

All products or service names mentioned in this document are trademarks of the companies with which they are associated.

---



## SAFETY PRECAUTIONS

Please read all instructions before attempting to unpack, install or operate this equipment and before connecting the power supply. Please keep the following in mind as you unpack and install this equipment:

- Always follow basic safety precautions to reduce the risk of fire, electrical shock and injury to persons.
- To prevent fire or shock hazard, do not expose the unit to rain, moisture or install this product near water.
- Never spill liquid of any kind on or into this product.
- Never push an object of any kind into this product through any openings or empty slots in the unit, as you may damage parts inside the unit.
- Do not attach the power supply cabling to building surfaces.
- Use only the supplied power supply unit (PSU). Do not use the PSU if it is damaged.
- Do not allow anything to rest on the power cabling or allow any weight to be placed upon it or any person walk on it.
- To protect the unit from overheating, do not block any vents or openings in the unit housing that provide ventilation and allow for sufficient space for air to circulate around the unit.
- Please completely disconnect the power when the unit is not in use to avoid wasting electricity.

## VERSION HISTORY

REV.	DATE	SUMMARY OF CHANGE
<b>RDV1</b>	2019/11/13	Preliminary release
<b>RDV2</b>	2020/02/10	Correction to relay commands and connection diagram



## CONTENTS

<b>1. Introduction</b> .....	<b>1</b>
<b>2. Applications</b> .....	<b>2</b>
<b>3. Package Contents</b> .....	<b>2</b>
<b>4. System Requirements</b> .....	<b>2</b>
<b>5. Features</b> .....	<b>3</b>
<b>6. Operation Controls and Functions</b> .....	<b>4</b>
6.1 Front Panel.....	4
6.2 Rear Panel.....	5
6.3 Remote Control .....	7
6.4 IR Cable Pinouts.....	8
6.5 RS-232 Pinout and Defaults .....	8
6.6 OSD Menu.....	9
6.7 WebGUI Control .....	15
6.7.1 Video Switch Tab.....	17
6.7.2 Audio Tab.....	19
6.7.3 Relay Tab .....	20
6.7.4 OSD Setting Tab.....	20
6.7.5 Automation Tab.....	21
6.7.6 EDID Tab.....	24
6.7.7 Network Tab .....	26
6.7.8 System Tab.....	27
6.8 Telnet Control .....	28
6.9 Serial and Telnet Commands .....	29
<b>7. Connection Diagram</b> .....	<b>48</b>
<b>8. Specifications</b> .....	<b>49</b>
8.1 Technical Specifications .....	49
8.2 Video Specifications .....	50
8.3 Audio Specifications .....	52
8.3.1 Digital Audio .....	52
8.3.2 Analog Audio .....	53
8.4 Cable Specifications .....	54
8.5 HDBaseT Features.....	55
<b>9. Acronyms</b> .....	<b>56</b>

---



## 1. INTRODUCTION

This UHD<sup>+</sup> HDMI over HDBaseT Receiver with Amplifier is a 2 by 1 switch with standard HDMI and HDBaseT inputs, an HDMI output, as well as both standard and amplified stereo audio outputs. This unit's HDBaseT input can receive uncompressed high-definition 4K UHD (up to 10.2Gbps) video along with Ethernet, RS-232 and IR control over a single cable up to a distance of 100 meters while the HDMI input supports high bandwidth 4K UHD<sup>+</sup> sources (up to 18Gbps) with support for 10/12-bit HDR. Pass-through of multiple digital audio formats such as LPCM (up to 8 channels), Bitstream and HD Bitstream is also supported via the HDBaseT and HDMI inputs. Additionally, the integrated headphone mini-jack and class D stereo amplifier outputs provide easy ways to extract audio from the currently selected source (LPCM 2.0 sources only) for local playback, offering a flexible sound experience.

Signal management features such as automatic switching based on input signal and hot plug detection enable convenient hands-free operation. There are also four built-in switching relay connections allowing control over direct power devices such as projection screens, curtains, lights, etc. Front panel controls and a comprehensive WebGUI provide access to manual input selection, volume control, as well as additional functionality such as EDID management, HDCP management and control over the four relay ports.

This switching receiver is ideal for use in residential or commercial point to point applications that require long HDBaseT signal transmission distances such as home theaters, conference rooms, huddle rooms, or lecture halls. The integrated PoH (Power over HDBaseT) feature can provide power to compatible transmitters, providing greater flexibility in installations. This unit can be controlled in a wide variety of different ways including front panel buttons, WebGUI, Telnet, and RS-232.

## 2. APPLICATIONS

- Household entertainment sharing and control
- Lecture room display and control
- Showroom display and control
- Meeting room presentation and control
- Classroom display and control

## 3. PACKAGE CONTENTS

- 1×UHD<sup>+</sup> HDMI over HDBaseT Receiver with Amplifier
- 1×24V/3.75A DC Power Adapter
- 1×Power Cord
- 1×3.5mm to IR Extender Cable
- 1×3.5mm to IR Blaster Cable
- 1×Remote Control (CR-188)
- 1×Rackmount Ears (Set of 2)
- 1×Shockproof Feet (Set of 4)
- 1×Operation Manual

## 4. SYSTEM REQUIREMENTS

- HDMI source equipment such as a media player, video game console or set-top box.
- HDMI receiving equipment such as an HDTV, monitor or audio amplifier.
- A compatible HDBaseT transmitter with PoH (PD) support is recommended.
- The use of Premium High Speed HDMI cables, and industry standard Cat.6, Cat.6A or Cat.7, is highly recommended.



## 5. FEATURES

- HDMI 2.0 and HDBaseT 1.0 compatible
- HDCP 1.x and 2.2 compliant
- 1×HDMI and 1×HDBaseT inputs
- 1×HDMI output
- HDBaseT input supports resolutions up to 4K@60Hz (4:2:0, 8-bit) or 4K@30Hz (4:4:4, 8-bit).
- HDMI input and output supports resolutions up to 4K UHD\* (18Gbps, 4K@60Hz 4:4:4, 8-bit)
- Supports Deep Color input and output up to 12-bit at 1080p60
- Supports 10-bit and 12-bit HDR (High Dynamic Range) input/output (HDMI bypass only)
- Supports CEC bypass
- Comprehensive EDID and HDCP management
- HDBaseT feature support: HD Video and Audio, 100BaseT Ethernet, PoH (PSE) and Control (bi-directional IR/RS-232 pass-through)
- HDBaseT input receives video, audio and data over a single Cat.5e/6/7 cable and can reach distances up to 100m/328ft at 4K when using Cat.6A/7
- Supports standard PoH (PSE) from the HDBaseT input to connected HDBaseT (PD) transmitters (compatible transmitters only)
- Supports pass-through of HD audio formats including LPCM (up to 8 channels), Bitstream, and HD Bitstream
- High performance and efficient 2 channel, class D amplifier with 20 watts of power per channel and volume control
- Controllable via front panel buttons, WebGUI, Telnet, and RS-232

## 6. OPERATION CONTROLS AND FUNCTIONS

### 6.1 Front Panel

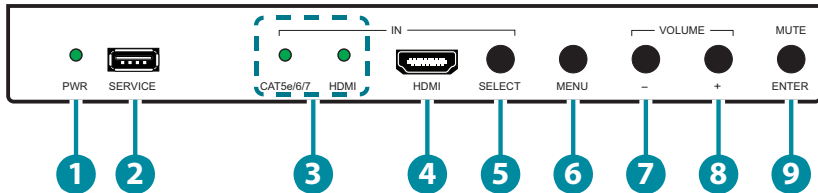

- 1 POWER LED:** This LED will illuminate to indicate the unit is on and receiving power.
- 2 SERVICE Port:** This slot is reserved for firmware update use only.
- 3 CAT5e/6/7 & HDMI LEDs:** The illuminated LED indicates which source is currently selected.
- 4 HDMI IN Port:** Connect to HDMI source equipment such as a media player, game console or set-top box.
- 5 SELECT Button:** Press this button to switch between the HDMI and HDBaseT inputs.
- 6 MENU Button:** Press to enter the OSD menu, or to back out from menu items.
- 7 - (MINUS)/Volume - Button:** Press to move down or adjust selections within OSD menus. Pressing this button while not in a menu will decrease the amplified analog audio output (L/R) volume.
- 8 + (PLUS)/Volume + Button:** Press to move up or adjust selections within OSD menus. Pressing this button while not in a menu will increase the amplified analog audio output (L/R) volume.
- 9 ENTER/MUTE Button:** Press to confirm a selection within the OSD or to go deeper into a menu item. Pressing this button while not in a menu will toggle the mute function of the amplified analog audio output (L/R).

## 6.2 Rear Panel

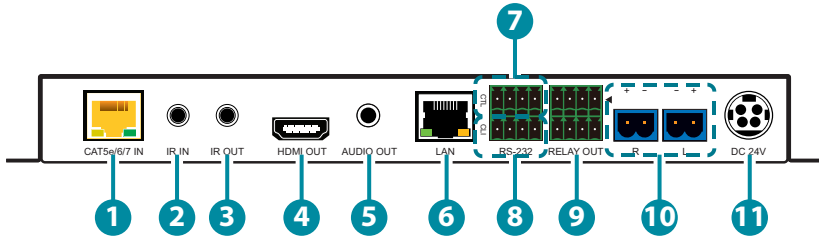

- 1 CAT5e/6/7 IN Port:** Connect to a compatible HDBaseT transmitter with a single Cat.5e/6/7 cable for reception of all data signals. PoH will also be supplied to a connected compatible PD transmitter.

*Note: The PoH function is designed to power compatible transmitter units only. Non-PoH transmitters will need their own power supply. Other brands of transmitter may not be compatible.*

- 2 IR IN Port:** Connect to an IR Extender to receive local IR signals to control this unit as well as to extend them to devices connected to the other end of the HDBaseT connection. Ensure that the remote being used is within direct line-of-sight of the IR Extender.
- 3 IR OUT Port:** Connect to an IR Blaster to transmit IR signals from the other end of the HDBaseT connection to devices within direct line-of-sight of the IR Blaster.
- 4 HDMI OUT Port:** Connect to an HDMI TV, monitor, or amplifier for digital video and audio output.
- 5 AUDIO OUT Port:** Connect to powered speakers, headphones, or an amplifier for analog stereo audio output.
- 6 LAN Port:** Connect directly, or through a network switch, to your PC/laptop to control the unit via Telnet/WebGUI and to extend the network across the HDBaseT connection.
- 7 RS-232 CTL 4-pin Terminal Block:** Connect directly to a PC, laptop, or other serial control device with a 3-pin adapter cable to send RS-232 commands to control the unit.

*Note: The 24 volt pins are included to provide power to a dedicated external control product and should NOT be used when connecting a standard RS-232 device.*

- 8 RS-232 CLI 4-pin Terminal Block:** Connect to a PC, laptop, or serial controllable device with a 3-pin adapter cable for the extension of RS-232 signals between both ends of the HDBaseT connection.

*Note: The 24 volt pins are included to provide power to a dedicated external control product and should NOT be used when connecting a standard RS-232 device.*

- 9 RELAY OUT 8-pin Terminal Block:** Connect to devices that can be powered and controlled via a DC 0~24V/5A relay connection such as a curtain, projection screen, or lights.

- 10 L/R 2-pin Terminal Blocks:** Connect to unpowered 4 $\Omega$  speakers for analog stereo audio output. Up to 20W of power is provided to each speaker.

- 11 DC 24V Port:** Plug the 24V DC power adapter into this port and connect it to an AC wall outlet for power.

## 6.3 Remote Control

- 1 HDBT Button:** Press to switch to the HDBaseT input.
- 2 HDMI Button:** Press to switch to the HDMI input.
- 3 MENU Button:** Press to enter the OSD menu, or to back out from menu items.
- 4 ENTER Button:** Press to confirm a selection within the OSD or to go deeper into a menu item. Pressing this button while not in a menu will toggle the mute function of the amplified analog audio output (L/R).
- 5 - (MINUS) Button:** Press to move down or adjust selections within OSD menus. Pressing this button while not in a menu will decrease the amplified analog audio output (L/R) volume.
- 6 + (PLUS) Button:** Press to move up or adjust selections within OSD menus. Pressing this button while not in a menu will increase the amplified analog audio output (L/R) volume.

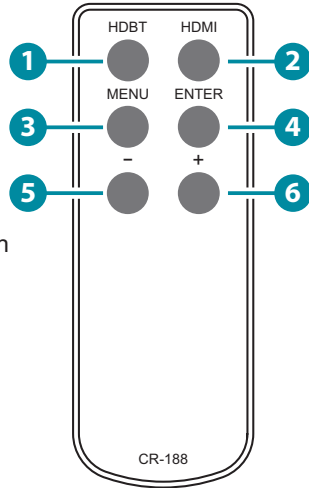

## 6.4 IR Cable Pinouts

IR Blaster Cable

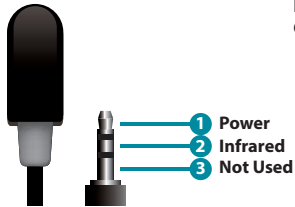

IR Extender Cable

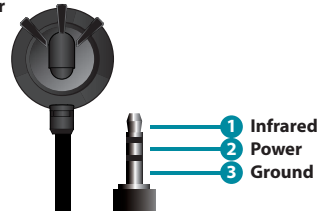

## 6.5 RS-232 Pinout and Defaults

Serial Port Default Settings	
Baud Rate	19200
Data Bits	8
Parity Bits	None
Stop Bits	1
Flow Control	None

RS-232 Port 1 (CTL)

4-pin Terminal Block

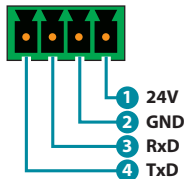

RS-232 Port 2 (CLI)

4-pin Terminal Block

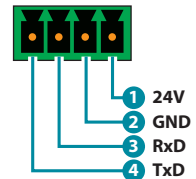

## 6.6 OSD Menu

All functions of this unit can be controlled by using the OSD (On Screen Display) which is activated by pressing the MENU button on the front of the unit. Use the + (PLUS), - (MINUS), and ENTER buttons to navigate the OSD menu. Press the MENU button to back out from any menu item and then press it again to close the menu.

MAIN MENU
L/R Audio Control
HDCP Mode
EDID Mode
OSD Setting
Ethernet Setting
System Setting
Video Information

The individual functions of the OSD will be introduced in the following section. Items marked in **BOLD** are the factory default settings.

L/R AUDIO CONTROL	
2ND LEVEL	3RD LEVEL
Amp. Volume	0~100 [30]
Amp. Mute	<b>OFF</b>
	On
Line Volume	0~100 [80]
Line Mute	<b>OFF</b>
	On
ARC	<b>OFF</b>
	On
Exit	

- 1) **Amp. Volume:** Set the volume level for the amplified output.
- 2) **Amp. Mute:** Enable or disable muting the amplified audio output.
- 3) **Line Volume:** Set the volume level for the line audio output.
- 4) **Line Mute:** Enable or disable muting the line audio output.
- 5) **ARC:** Enable or disable ARC (Audio Return Channel) support. When enabled, ARC audio from the display connected to the HDMI output will be directed to the analog outputs.

*Note: ARC must also be enabled on the connected HDMI display. LPCM 2.0 ARC sources only.*

HDCP MODE	
2ND LEVEL	3RD LEVEL
In 1	Follow Display
	<b>FOLLOW INPUT</b>
	Disable
In 2	Follow Display
	<b>FOLLOW INPUT</b>
	Disable
Exit	

- 1) **In 1:** Provides control over the HDCP behavior of the HDMI input.
- 2) **In 2:** Provides control over the HDCP behavior of the HDBaseT input.

EDID MODE		
2ND LEVEL	3RD LEVEL	4TH LEVEL
<b>ALL MODE</b>	<b>FHD/PCM/2CH</b>	
	FHD/PCM/MCH	
	UHD/PCM/2CH	
	UHD/PCM/MCH	
	UHD*/PCM/2CH	
	UHD*/PCM/MCH	
	User 1	
	User 2	
	Sink	

EDID MODE		
2ND LEVEL	3RD LEVEL	4TH LEVEL
Appoint Mode	In 1	<b>FHD/PCM/2CH</b>
		FHD/PCM/MCH
		UHD/PCM/2CH
		UHD/PCM/MCH
		UHD*/PCM/2CH
		UHD*/PCM/MCH
		User 1
		User 2
		Sink
	In 2	<b>FHD/PCM/2CH</b>
		FHD/PCM/MCH
		UHD/PCM/2CH
		UHD/PCM/MCH
		UHD*/PCM/2CH
		UHD*/PCM/MCH
		User 1
		User 2
		Sink
Exit		

1) **EDID Mode:** Select how to assign EDIDs to the unit’s inputs. Selecting “Appoint Mode” allows for a different EDID to be assigned to each input, selecting “All Mode” allows for a single EDID to be assigned to both inputs.

- **All Mode:** Select the EDID to assign to all inputs.
- **Appoint Mode:** Select the EDIDs to assign to input 1 (HDMI) and input 2 (HDBaseT).

*Note: In most cases, assigning a new EDID to an input will cause the affected input to briefly blink out while the source adapts to the new information.*

OSD SETTING	
2ND LEVEL	3RD LEVEL
Timeout	0~100 <b>[8]</b>
H. Position	0~100% <b>[25%]</b>
V. Position	0~100% <b>[25%]</b>
Transparency	0~7 <b>[0]</b>
Exit	

- 1) **Timeout:** Set the length of time to wait before automatically turning off the OSD menu if there is no user interaction. The timer is disabled when the value is set to 0.
- 2) **H. Position:** Set the horizontal position of the OSD menu.
- 3) **V. Position:** Set the vertical position of the OSD menu.
- 4) **Transparency:** Set the transparency level of the OSD menu's background. A setting of 0 is completely opaque and a setting of 7 is completely transparent.

ETHERNET SETTING		
2ND LEVEL	3RD LEVEL	4TH LEVEL
DHCP Mode	IP Address	[Displays DHCP network details]
	Netmask	
	Gateway	
<b>STATIC MODE</b>	IP Address	<b>192.168.1.50</b>
	Netmask	<b>255.255.255.0</b>
	Gateway	<b>192.168.1.254</b>
Re-Link		
Exit		

- 1) **IP Mode:** Set the unit's IP address assignment mode to Static or DHCP. When DHCP Mode is selected, all IP configuration information will be assigned automatically by the local DHCP server. When Static Mode is selected, the IP address, netmask, and gateway address must be set manually.

*Note: The unit's default static IP address is 192.168.1.50.*

- 2) **Re-Link:** Select this to force the unit to update its Ethernet settings.

SYSTEM SETTING	
2ND LEVEL	3RD LEVEL
Auto Switch	<b>ON</b>
	Off
Relay Output 1	<b>OFF</b>
	On
Relay Output 2	<b>OFF</b>
	On
Relay Output 3	<b>OFF</b>
	On
Relay Output 4	<b>OFF</b>
	On
Exit	

- 1) **Auto Switch:** Enable or disable the unit's auto switch feature.
- 2) **Relay Output 1-4:** Manually open or close Relays 1~4. Selecting "ON" closes the relay, selecting "OFF" opens it.

VIDEO INFORMATION	
2ND LEVEL	3RD LEVEL
In	[Displays current status details]
Out	
Rx	

- 1) **Video Information:** This screen displays information about the unit's current state, input and output status, as well as the current firmware version.

## 6.7 WebGUI Control

### • Device Discovery

Please obtain the “Device Discovery” software from your authorized dealer and save it in a directory where you can easily find it.

Connect the unit and your PC/Laptop to the same active network and execute the “Device Discovery” software. Click on “Find Devices on Network” and a list of devices connected to the local network will show up indicating their current IP address.

*Note: The unit’s default IP address is 192.168.1.50.*



Product Name	Description	IP Address	MAC Address

By clicking on one of the listed devices you will be presented with the network details of that particular device.

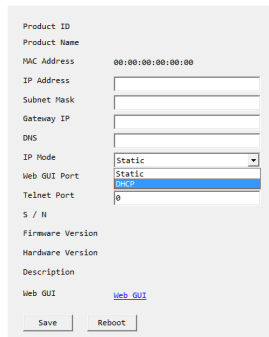

Product ID  
Product Name  
MAC Address 00:00:00:00:00  
IP Address  
Subnet Mask  
Gateway IP  
DNS  
IP Mode Static  
Web GUI Port Static  
Telnet Port 0  
S / N  
Firmware Version  
Hardware Version  
Description  
Web GUI [Web GUI](#)  
Save Reboot

- 1) **IP Mode:** If you choose, you can alter the static IP network settings for the device, or switch the unit into DHCP mode to automatically obtain proper network settings from a local DHCP server. To switch to DHCP mode, please select DHCP from the IP mode drop-down, then click “Save” followed by “Reboot”.
- 2) **WebGUI Hotkey:** Once you are satisfied with the network settings, you may use them to connect via Telnet or WebGUI. The network information window provides a convenient link to launch the WebGUI directly.

## • WebGUI Overview

After connecting to the WebGUI's address in a web browser, the login screen will appear. Please enter the appropriate user name and password then click "Submit" to log in.

*Note: The default user name and password is "admin".*

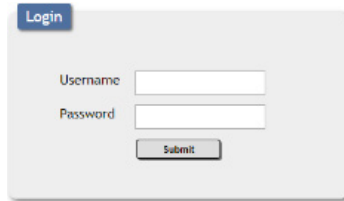

A login form with a blue "Login" button at the top left. Below it are two input fields: "Username" and "Password". At the bottom center is a "Submit" button.

On the left side of the browser you will see the following menu tabs where all primary functions of the unit are controllable via the built in WebGUI. The individual functions will be introduced in the following sections.



Clicking the red "Logout" tab will automatically log the currently connected user out of the WebGUI and return to login page.

## 6.7.1 Video Switch Tab

This tab provides A/V routing control, HDCP management, auto switch control, A/V muting, and I/O renaming options. To assign a new video route, please click the Output button on the left and then click on the button of the preferred input port on the right. As each button is selected they will become highlighted. The new route will become active immediately and the routing information displayed on the buttons will change accordingly. If a specially supported switching transmitter is connected, it is also possible to select the specific input to route from it.

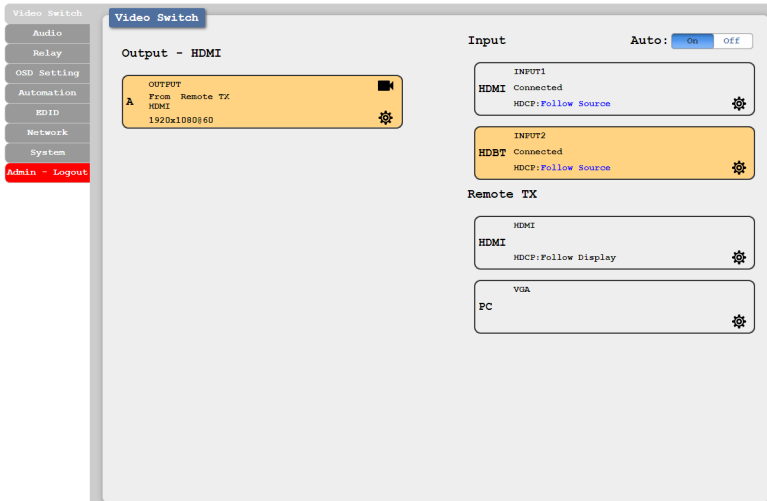

- 1) **Output:** This button selects the output to route A/V Inputs to. Details about the output name and currently selected Input are also displayed here. Clicking on the “Edit” icon (⚙️) opens up the Output Edit window. Clicking on the “A/V Mask” icon (🔇) will mute or unmute the audio and video output.
- 2) **Auto:** Auto switching may be enabled or disabled by clicking on the On/Off slider to toggle the setting.
- 3) **Input:** Buttons for selecting the input (HDMI or HDBaseT) to route to the output. Details about the input names and current sync/HDCP status are also displayed here. Clicking on the “Edit” icon (⚙️) opens up the Input Edit window.

- 4) **Remote TX (Compatible transmitters only):** Buttons for selecting the input on the connected transmitter. Details about the input names and current sync/HDCP status are also displayed here. Clicking on the “Edit” icon (✎) opens up the Input Edit window.
- 5) **Output Edit:** Provides control over the name of the output.
  - **Set Output Name:** To rename the output, type the new name in the space provided in the Edit window. The name can be up to 32 characters long. Click the “Save” button to confirm the change.
- 6) **Input Edit:** Provides Individual control over the name of each input and the behavior of HDCP on that input.

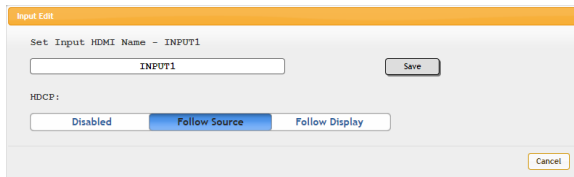

- **Set Input Name:** To rename an input, type the new name in the space provided in the Edit window. The name can be up to 32 characters long. Click the “Save” button to confirm the change.
- **HDCP:** The HDCP mode of each input can be set to “Follow Source”, “Follow Display”, or “Disabled”. Changes made to this setting occur immediately.

## 6.7.2 Audio Tab

This tab provides control over the volume level of the amplified and line level analog audio outputs.

*Note: HDMI audio output is always a direct pass-through from the selected source and is not affected by the controls on this tab.*

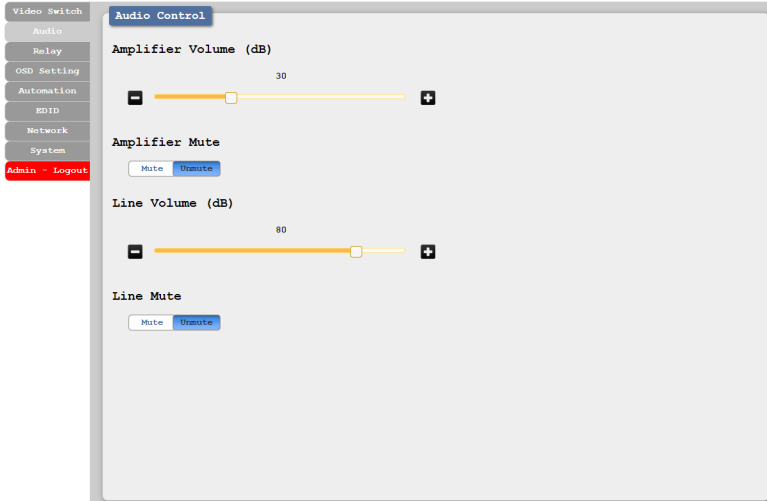

- 1) **Amplifier Volume (dB):** Allows the adjustment of the amplified analog audio output's volume level. The available adjustment range is 0 to 100.
- 2) **Amplifier Mute:** Mute or unmute the amplified analog audio output.
- 3) **Line Volume (dB):** Allows the adjustment of the line level analog audio output's volume level. The available adjustment range is 0 to 100.
- 4) **Line Mute:** Mute or unmute the line level analog audio output.

### 6.7.3 Relay Tab

This tab provides direct control over the unit's 4 relay ports.



- 1) **Relay Out Port 1~4:** Manually open or close Relays 1~4. Selecting “ON” closes the relay, selecting “OFF” opens it.

### 6.7.4 OSD Setting Tab

This tab provides control over the timeout, transparency, and position of the OSD menu displayed on the HDMI output.

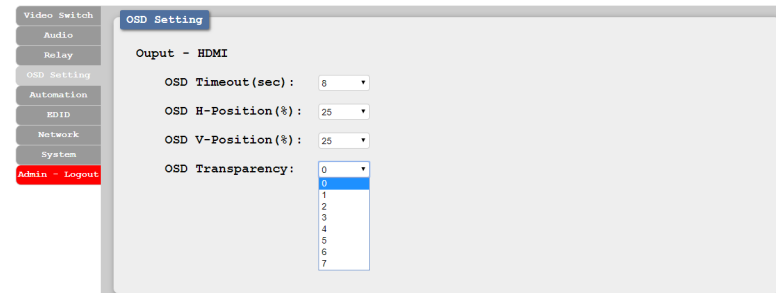

- 1) **OSD Timeout (sec):** Use the dropdown to set the OSD menu timeout in seconds. The range is from 0 (no timeout) to 100.
- 2) **OSD H-Position (%):** Use the dropdown to set the OSD menu's horizontal position in percentage.
- 3) **OSD V-Position (%):** Use the dropdown to set the OSD menu's vertical position in percentage.
- 4) **OSD Transparency:** Select the OSD menu's background transparency level. The range is from 0 (opaque) to 7 (transparent).

## 6.7.5 Automation Tab

This tab provides control over the unit's automatic control command broadcast behavior when any of the specified Automation Events occur. Automation commands can be sent to connected devices via IR, CEC, and RS-232.

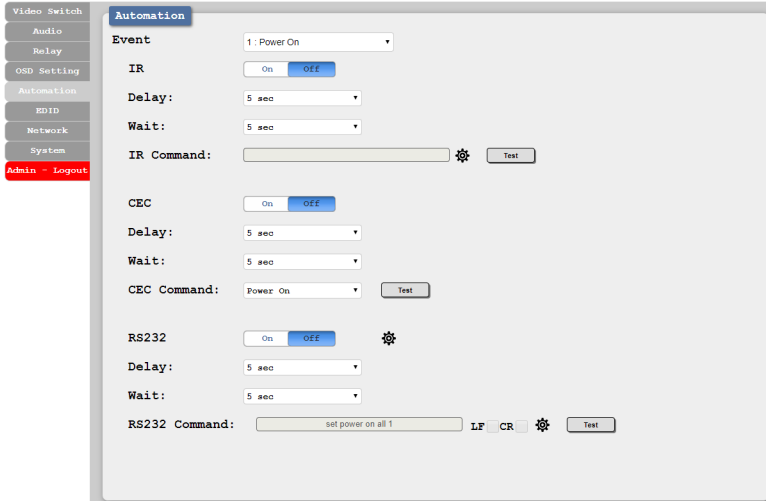

- 1) **Event:** Use the dropdown to select the Automation Event to configure. Available Automation Events are:
  - **Power On:** This unit is powered on.
  - **Out A Source Active:** The currently selected input changes from inactive to active.
  - **Out A Source Lost:** The currently selected input changes from active to inactive.
- 2) **IR:** Enable or disable sending an IR command when the currently selected Automation Event is activated.
  - **Delay:** Set the length of time, in seconds, that the specified Automation Event must continue to be true before sending the defined IR command.
  - **Wait:** Set the length of time, in seconds, to wait after this IR Automation Event has been activated before ANY other Automation Event can be detected.

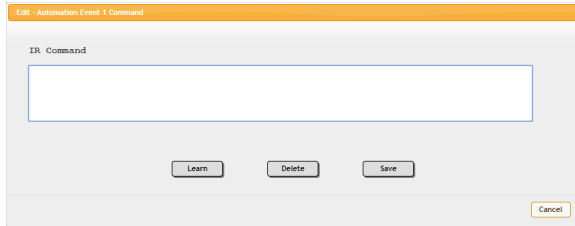

- **IR Command:** Shows the IR command (in ASCII hex pairs) that will be sent when the specified Automation Event is activated. Click the “Edit” icon (⚙️) to learn the command from an IR remote. Click the “Test” button to send the command immediately.
- 3) **CEC:** Enable or disable sending a CEC command when the currently selected Automation Event is activated.

*Note: CEC support must also be enabled on the connected HDMI display device.*

- **Delay:** Set the length of time, in seconds, that the specified Automation Event must continue to be true before sending the defined CEC command.
- **Wait:** Set the length of time, in seconds, to wait after this IR Automation Event has been activated before ANY other Automation Event can be detected.
- **CEC Command:** Set the CEC command to send when the specified Automation Event is activated. Click the “Test” button to send the command immediately. Available CEC commands are:
  - **Power Off:** Turn off the connected HDMI display device.
  - **Power On:** Turn on the connected HDMI display device.
  - **Active Source:** Force the connected HDMI display device to switch to the HDMI input that this unit is connected to.

*Note: Not all HDMI devices support all CEC commands.*

- 4) **RS232:** Enable or disable sending an RS-232 command when the currently selected Automation Event is activated. Click the Edit icon (⚙️) to configure the RS-232 port.

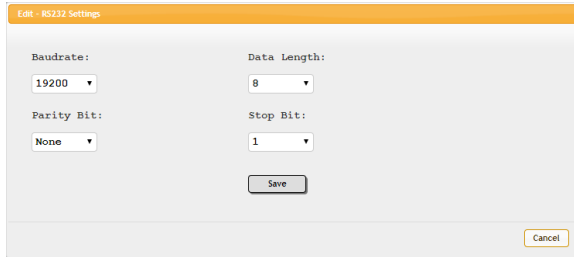

Dialog box titled "Edit - RS232 Settings". It contains the following fields:

- Baudrate: 19200
- Data Length: 8
- Parity Bit: None
- Stop Bit: 1

Buttons: Save, Cancel

*Note: RS-232 Automation commands will only be output over the “CTL” RS-232 port.*

- **Delay:** Set the length of time, in seconds, that the specified Automation Event must continue to be true before sending the defined RS-232 command.
- **Wait:** Set the length of time, in seconds, to wait after this RS-232 Automation Event has been activated before ANY other Automation Event can be detected.

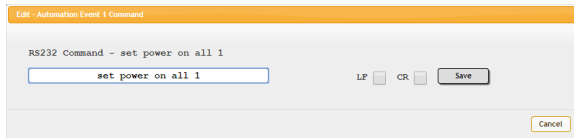

Dialog box titled "Edit - Automation Event 1 Command". It contains the following fields:

- RS232 Command - set power on all 1

Buttons: Save, Cancel, LF, CR

- **RS232 Command:** Click the Edit icon (⚙️) to define the RS-232 command to send when the specified Automation Event is activated. Click the “Test” button to send the command immediately.

## 6.7.6 EDID Tab

This tab provides control over the EDID settings of all inputs, including those on specially supported transmitters. This unit provides the option of six standard EDIDs, one sink sourced EDID and two user uploaded EDIDs that can be assigned to each input port individually. The names of the two user uploaded EDIDs can be changed if desired.

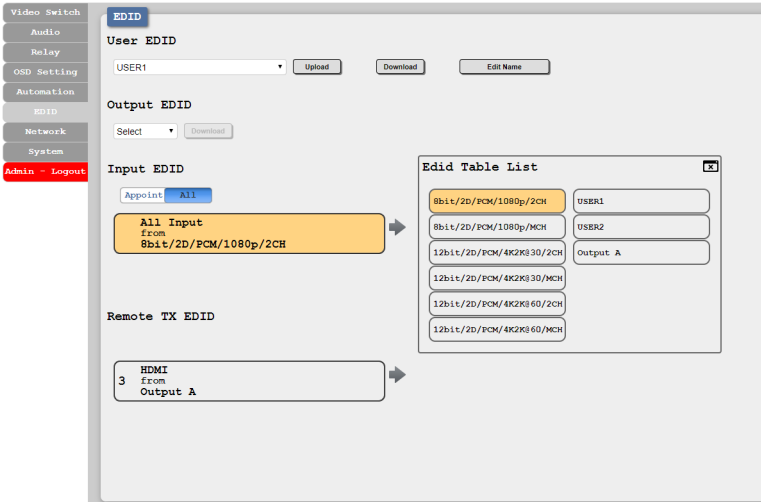

### 1) User EDID:

- **Upload:** To upload a User EDID, select the User EDID slot to upload into from the dropdown list and then click the “Upload” button. An EDID Upload window will appear, allowing you to locate and upload the preferred EDID file (\*.bin format) from a local PC. Once the correct file has been selected, please click the “Upload” button in the window, and the file will be transferred to the unit.
- **Download:** To save an existing User EDID to your local PC, select the User EDID slot from the dropdown list and then press the “Download” button. Depending on your browser settings you will either be asked where to save the downloaded file, or the file will be transferred to the default download location on your PC.

- **Edit Name:** Click the “Edit Name” button to open a window that allows changing the name of the User EDID. Click the “Save” button within the window to confirm the change.

**2) Output EDID:**

- **Download:** To save the EDID from the connected display to your local PC, select the sink from the dropdown list then press the “Download” button. Depending on your browser settings you will either be asked where to save the downloaded file, or the file will be transferred directly to the default download location on your PC.

**3) Input EDID:** This section provides controls for assigning EDID to the unit’s inputs. Selecting “Appoint” allows for different EDID to be assigned to each individual input, selecting “ALL” allows for a single EDID to be assigned to all inputs.

- **EDID Selection:** Click on the preferred input(s) to open the EDID Table List window. Multiple inputs can be selected at once, if desired. Select the new EDID source to use and the change will occur immediately.

*Note: In most cases, assigning a new EDID to an input will cause the affected input to briefly blink out while the source adapts to the new information.*

This unit provides the following 6 default EDIDs:

Unit’s default EDIDs	
<b>FHD/PCM/2CH</b>	1920×1080p@60Hz (4.95Gbps) & 8-bit color, LPCM 2.0
<b>FHD/PCM/MCH</b>	1920×1080p@60Hz (4.95Gbps) & 8-bit color, LPCM 7.1 & Bitstream
<b>UHD/PCM/2CH</b>	3840×2160p@30Hz (10.2Gbps) & Deep Color (8/10/12-bit), LPCM 2.0
<b>UHD/PCM/MCH</b>	3840×2160p@30Hz (10.2Gbps) & Deep Color (8/10/12-bit), LPCM 7.1 & Bitstream
<b>UHD*/PCM/2CH</b>	3840×2160p@60Hz (18Gbps) & Deep Color (8/10/12-bit), LPCM 2.0
<b>UHD*/PCM/MCH</b>	3840×2160p@60Hz (18Gbps) & Deep Color (8/10/12-bit), LPCM 7.1 & Bitstream

*Note: In some rare cases it is possible for custom or external EDIDs to cause compatibility issues with certain sources. If this happens, it*

is recommended to switch to one of the 6 default EDIDs for maximum compatibility.

- 3) **Remote Tx EDID (Compatible transmitters only):** Click on the transmitter’s button to open the EDID Table List window. Select the new EDID source to use, from the choices on the right, and the change will occur immediately on the transmitter.

*Note: Available default EDIDs will depend on the connected transmitter.*

### 6.7.7 Network Tab

This tab provides network configuration options including changing the IP mode, viewing/setting the IP configuration, changing the admin login password, and changing the Web Login timeout.

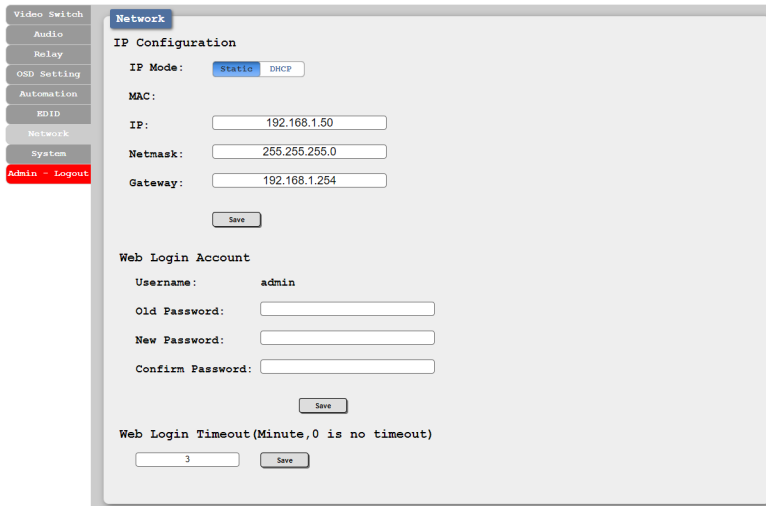

- 1) **IP Configuration:** IP Mode may be switched between Static IP or DHCP. In Static IP Mode the IP, netmask and gateway addresses must be manually set. When in DHCP Mode, the unit will attempt to connect to a local DHCP server and obtain IP, netmask and gateway addresses automatically. Please press “Save” after making any changes to the IP configuration or mode.

*Note: If the IP address is changed then the IP address required for WebGUI/Telnet access will also change accordingly*

- 2) **Web Login Account:** The WebGUI admin password can be changed here. Please press “Save” after entering the old and new passwords to enact the change.

*Note: The default password is “admin”.*

- 3) **Web Login Timeout:** Select the length of time to wait before logging the user out of the WebGUI due to inactivity. Available range is from 0 to 35970 minutes. Setting it to 0 will disable the timeout function.

### 6.7.8 System Tab

This tab provides system configuration backup/restore options, controls to perform a factory reset or system reboot, firmware update support, and the unit’s serial number.

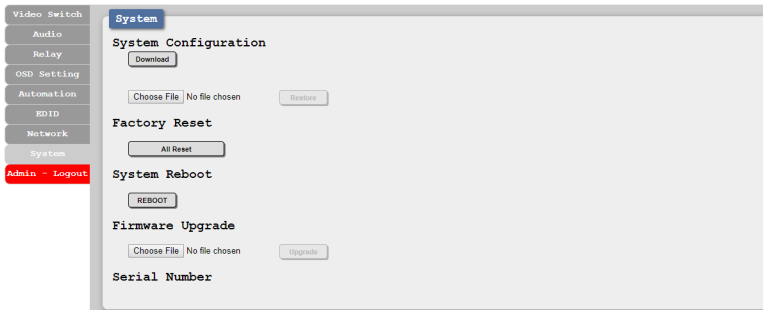

#### 1) System Configuration:

- **Download:** The current system configuration, including routing and settings, may be saved as an XML file to a PC. Click the “Download” button to save the current system configuration to your local PC.
- **Restore:** Previously saved system configurations may be restored from a saved XML file. Click the “Choose File” button to locate the saved XML file, then click the “Restore” button to upload and activate the selected configuration.

- 2) **Factory Reset:** Press the “ALL Reset” button to reset the unit to its factory default state. After the reset is complete, the unit will reboot automatically.

- 3) **System Reboot:** Click this button to reboot the unit.

- 4) **Firmware Upgrade:** To update the unit’s firmware, click the “Choose File” button to open the file selection window and then select the firmware

update file (\*.bin format) located on your local PC. After selecting the file, click the “Upgrade” button to begin the firmware update process. After the upgrade is complete, the unit will reboot automatically.

- 5) **Serial Number:** Displays the unit’s serial number.

## 6.8 Telnet Control

Before attempting to use Telnet control, please ensure that both the unit and the PC are connected to the same active networks.

To Access the Command Line Interface (CLI)	
Windows 7	Click <b>Start</b> , type “cmd” in the search field, and press <b>Enter</b> .
Windows XP	Click <b>Start &gt; Run</b> , type “cmd”, and press <b>Enter</b> .
Mac OS X	Click <b>Go &gt; Applications &gt; Utilities &gt; Terminal</b> .

Once in the Command Line Interface (CLI) type “**telnet**” followed by the IP address of the unit (and the port number if it is non-standard) and then hit “**Enter**”. This will connect us to the unit we wish to control.

```
Microsoft Windows [Version 6.1.7601]
Copyright (c) 2009 Microsoft Corporation. All rights reserved.

C:\Users\Administrator>telnet 192.168.1.50 23
```

*Note 1: If the IP address is changed then the IP address required for Telnet access will also change accordingly.*

*Note 2: The default IP address is 192.168.1.50.*

## 6.9 Serial and Telnet Commands

COMMAND	
Description and Parameters	
<b>help</b> ↵	Show the full command list.
<b>help N1</b> ↵	Show details about the specified command. <b>N1</b> = {Command}
<b>?</b> ↵	Show the full command list.
<b>? N1</b> ↵	Show details about the specified command. <b>N1</b> = {Command}
<b>set in N1 name N2</b> ↵	Set the name of the specified input. Available values for <b>N1</b> : 1 [HDMI input] 2 [HDBaseT input] <b>N2</b> = {Name} [32 characters maximum]
<b>get in N1 name</b> ↵	Show the current name of the specified input. Available values for <b>N1</b> : 1 [HDMI input] 2 [HDBaseT input]
<b>get in name list</b> ↵	List the names of all inputs on the unit.

COMMAND					
Description and Parameters					
<b>get in N1 hactive</b> ↵	<p>Show the horizontal active pixel value of the specified input's current video source.</p> <p>Available values for <b>N1</b>:</p> <table> <tr> <td>1</td> <td>[HDMI input]</td> </tr> <tr> <td>2</td> <td>[HDBaseT input]</td> </tr> </table>	1	[HDMI input]	2	[HDBaseT input]
1	[HDMI input]				
2	[HDBaseT input]				
<b>get in N1 vactive</b> ↵	<p>Show the vertical active pixel value of the specified input's current video source.</p> <p>Available values for <b>N1</b>:</p> <table> <tr> <td>1</td> <td>[HDMI input]</td> </tr> <tr> <td>2</td> <td>[HDBaseT input]</td> </tr> </table>	1	[HDMI input]	2	[HDBaseT input]
1	[HDMI input]				
2	[HDBaseT input]				
<b>get in N1 refresh rate</b> ↵	<p>Show the refresh rate of the specified input's current video source.</p> <p>Available values for <b>N1</b>:</p> <table> <tr> <td>1</td> <td>[HDMI input]</td> </tr> <tr> <td>2</td> <td>[HDBaseT input]</td> </tr> </table>	1	[HDMI input]	2	[HDBaseT input]
1	[HDMI input]				
2	[HDBaseT input]				
<b>get in N1 interlace</b> ↵	<p>Show the interlace state of the specified input's current video source.</p> <p>Available values for <b>N1</b>:</p> <table> <tr> <td>1</td> <td>[HDMI input]</td> </tr> <tr> <td>2</td> <td>[HDBaseT input]</td> </tr> </table>	1	[HDMI input]	2	[HDBaseT input]
1	[HDMI input]				
2	[HDBaseT input]				
<b>get in N1 deep color</b> ↵	<p>Show the detected bit depth of the signal on the specified input.</p> <p>Available values for <b>N1</b>:</p> <table> <tr> <td>1</td> <td>[HDMI input]</td> </tr> <tr> <td>2</td> <td>[HDBaseT input]</td> </tr> </table>	1	[HDMI input]	2	[HDBaseT input]
1	[HDMI input]				
2	[HDBaseT input]				
<b>get in N1 sync status</b> ↵	<p>Show the current sync state of the specified input.</p> <p>Available values for <b>N1</b>:</p> <table> <tr> <td>1</td> <td>[HDMI input]</td> </tr> <tr> <td>2</td> <td>[HDBaseT input]</td> </tr> </table>	1	[HDMI input]	2	[HDBaseT input]
1	[HDMI input]				
2	[HDBaseT input]				

COMMAND	
Description and Parameters	
<b>set out A name N1</b> ↵	
Set the name of the HDMI output.	
<b>N1</b> = {Name}	[Output A name]
<b>get out A name</b> ↵	
Show the name of the HDMI output.	
<b>set out A route N1</b> ↵	
Route the specified input to the HDMI output.	
Available values for <b>N1</b> :	
1	[HDMI input]
2	[HDBaseT input]
<b>get out A route</b> ↵	
Show the current input routed to the HDMI output.	
<b>set out A mask N1</b> ↵	
Enable or disable the a/v mask setting on the HDMI output.	
Available values for <b>N1</b> :	
ON	[Mask setting disabled]
OFF	[Mask setting enabled]
<b>get out A mask</b> ↵	
Display the current a/v mask setting for the HDMI output.	
<b>get out A deep color</b> ↵	
Show the bit depth currently used by the HDMI output.	
<b>get out A color space</b> ↵	
Show the color space format currently used by the HDMI output.	
<b>get out A sync status</b> ↵	
Show the current sync state of the HDMI output.	

COMMAND	
Description and Parameters	
<b>set out auto mode N1</b> ←	
Set the auto switching behavior of the unit.	
Available values for <b>N1</b> :	
0	[Auto switch disabled]
1	[Auto switch enabled]
<b>get out auto mode</b> ←	
Show the current auto switching mode of the unit.	
<b>set out A osd timeout N1</b> ←	
Set the OSD's timeout value for the HDMI output or disable the timeout.	
Available values for <b>N1</b> :	
0	[No timeout]
1~100	[Timeout in seconds]
<b>get out A osd timeout</b> ←	
Show the current OSD timeout value for the HDMI output.	
<b>set out A osd hposition N1</b> ←	
Set the horizontal position of the OSD on the HDMI output.	
<b>N1</b> = 0~100	[Horizontal position]
<b>get out A osd hposition</b> ←	
Show the current horizontal position of the OSD on the HDMI output.	
<b>set out A osd vposition N1</b> ←	
Set the vertical position of the OSD on the HDMI output.	
<b>N1</b> = 0~100	[Vertical position]
<b>get out A osd vposition</b> ←	
Show the current vertical position of the OSD on the HDMI output.	
<b>set out A osd transparency N1</b> ←	
Set the transparency level of the OSD on the HDMI output.	
<b>N1</b> = 0~7	[Transparency level]

COMMAND	
Description and Parameters	
<b>get out A osd transparency</b> ↵	
	Show the current transparency level of the OSD on the HDMI output.
<b>set edid N1 name N2</b> ↵	
	Set the name for the specified EDID. (Only User EDIDs may be renamed)
<b>N1</b> = 7~8	[EDID number]
<b>N2</b> = {Name}	[16 characters maximum]
<b>get edid N1 name</b> ↵	
	Show the name for the specified EDID.
<b>N1</b> = 7~8	[EDID number]
<b>set all in edid mode N1</b> ↵	
	Select the EDID management mode to use (All or Appoint) for all inputs.
	Available values for <b>N1</b> :
OFF	[Appoint EDID mode]
ON	[All EDID mode]
<b>get all in edid mode</b> ↵	
	Show the current EDID management mode used by all inputs.
<b>set all in edid N1</b> ↵	
	Set the EDID to use when the "All" EDID mode is active.
	Available values for <b>N1</b> :
1	[Internal EDID 1]
2	[Internal EDID 2]
3	[Internal EDID 3]
4	[Internal EDID 4]
5	[Internal EDID 5]
6	[Internal EDID 6]
7	[User EDID 1]
8	[User EDID 2]
9	[Sink EDID]
<b>get all in edid</b> ↵	
	Show the current EDID used by the "All" EDID mode.

COMMAND	
Description and Parameters	
<b>set in N1 edid N2</b> ↵	
Set the EDID to use on the specified input.	
Available values for <b>N1</b> :	
1	[HDMI input]
2	[HDBaseT input]
Available values for <b>N2</b> :	
1	[Internal EDID 1]
2	[Internal EDID 2]
3	[Internal EDID 3]
4	[Internal EDID 4]
5	[Internal EDID 5]
6	[Internal EDID 6]
7	[User EDID 1]
8	[User EDID 2]
9	[Sink EDID]
<b>get in N1 edid</b> ↵	
Show the EDID currently being used on the specified input.	
Available values for <b>N1</b> :	
1	[HDMI input]
2	[HDBaseT input]
<b>get in edid list</b> ↵	
List all available EDID selections.	
<b>set user N1 edid data N2</b> ↵	
Upload a new EDID (in ASCII hex format) for use as the specified User EDID.	
<b>N1</b> = 1~2	[User EDID]
<b>N2</b> = {Hex pairs}	[EDID data]
<b>get user N1 edid data</b> ↵	
Show the current contents of the specified User EDID as ASCII hex data.	
<b>N1</b> = 1~2	[User EDID]

COMMAND	
Description and Parameters	
<b>get in N1 hdcp status</b> ↵	
Show the current HDCP status of the specified input.	
Available values for <b>N1</b> :	
1	[HDMI input]
2	[HDBaseT input]
Possible response values:	
0	[HDCP off]
1	[HDCP 1.x]
2	[HDCP 2.2]
<b>set in N1 hdcp mode N2</b> ↵	
Set the HDCP behavior of the specified input.	
Available values for <b>N1</b> :	
1	[HDMI input]
2	[HDBaseT input]
Available values for <b>N2</b> :	
0	[HDCP support disabled]
1	[Refer to source]
2	[Refer to display]
<b>get in N1 hdcp mode</b> ↵	
Show the current HDCP behavior used by the specified input.	
Available values for <b>N1</b> :	
1	[HDMI input]
2	[HDBaseT input]
<b>get in hdcp mode list</b> ↵	
Show all available HDCP method.	
<b>get out A hdcp status</b> ↵	
Show the current HDCP status of the HDMI output.	
Possible response values:	
0	[HDCP off]
1	[HDCP 1.x]
2	[HDCP 2.2]

COMMAND									
Description and Parameters									
<b>set audio out N1 volume N2↵</b>	<p>Set the volume level of the specified output's audio.</p> <p>Available values for <b>N1</b>:</p> <table> <tr> <td>A</td> <td>[Amplified audio output]</td> </tr> <tr> <td>B</td> <td>[Line audio output]</td> </tr> </table> <p><b>N2</b> = 0~100 [Volume level]</p>	A	[Amplified audio output]	B	[Line audio output]				
A	[Amplified audio output]								
B	[Line audio output]								
<b>get audio out N1 volume↵</b>	<p>Show the current volume level of the specified output's audio.</p> <p>Available values for <b>N1</b>:</p> <table> <tr> <td>A</td> <td>[Amplified audio output]</td> </tr> <tr> <td>B</td> <td>[Line audio output]</td> </tr> </table>	A	[Amplified audio output]	B	[Line audio output]				
A	[Amplified audio output]								
B	[Line audio output]								
<b>set audio out N1 volume up↵</b>	<p>Increase the volume level of the specified output's audio by 1 unit.</p> <p>Available values for <b>N1</b>:</p> <table> <tr> <td>A</td> <td>[Amplified audio output]</td> </tr> <tr> <td>B</td> <td>[Line audio output]</td> </tr> </table>	A	[Amplified audio output]	B	[Line audio output]				
A	[Amplified audio output]								
B	[Line audio output]								
<b>set audio out N1 volume down↵</b>	<p>Decrease the volume level of the specified output's audio by 1 unit.</p> <p>Available values for <b>N1</b>:</p> <table> <tr> <td>A</td> <td>[Amplified audio output]</td> </tr> <tr> <td>B</td> <td>[Line audio output]</td> </tr> </table>	A	[Amplified audio output]	B	[Line audio output]				
A	[Amplified audio output]								
B	[Line audio output]								
<b>set audio out N1 mute N2↵</b>	<p>Enable or disable muting the specified audio output.</p> <p>Available values for <b>N1</b>:</p> <table> <tr> <td>A</td> <td>[Amplified audio output]</td> </tr> <tr> <td>B</td> <td>[Line audio output]</td> </tr> </table> <p>Available values for <b>N2</b>:</p> <table> <tr> <td>OFF</td> <td>[Mute off]</td> </tr> <tr> <td>ON</td> <td>[Mute on]</td> </tr> </table>	A	[Amplified audio output]	B	[Line audio output]	OFF	[Mute off]	ON	[Mute on]
A	[Amplified audio output]								
B	[Line audio output]								
OFF	[Mute off]								
ON	[Mute on]								

COMMAND	
Description and Parameters	
<b>get audio out N1 mute</b> ↵	
Show the current mute state of the specified output.	
Available values for <b>N1</b> :	
A	[Amplified audio output]
B	[Line audio output]
<b>set audio out arc N1</b> ↵	
Enable or disable ARC support on the HDMI output.	
Available values for <b>N1</b> :	
OFF	[ARC disabled]
ON	[ARC enabled]
<b>get audio out arc</b> ↵	
Show the current state of ARC support on the HDMI output.	
<b>get ipconfig</b> ↵	
Show the unit's current IP configuration information.	
<b>set ip mode N1</b> ↵	
Set the IP address assignment mode.	
Available values for <b>N1</b> :	
0	[Static IP mode]
1	[DHCP mode]
<b>get ip mode</b> ↵	
Show the current IP address assignment mode.	
<b>set ipaddr N1</b> ↵	
Set the unit's static IP address.	
<b>N1</b> = X.X.X.X	[X = 0~255, IP address]
<b>get ipaddr</b> ↵	
Show the unit's current IP address.	
<b>set netmask N1</b> ↵	
Set the unit's static netmask.	
<b>N1</b> = X.X.X.X	[X = 0~255, netmask]

COMMAND	
Description and Parameters	
<b>get netmask</b> ↵	Show the unit's current netmask.
<b>set gateway N1</b> ↵	Set the unit's static gateway address. <b>N1</b> = X.X.X.X [X = 0~255, gateway address]
<b>get gateway</b> ↵	Show the unit's current gateway address.
<b>set webgui password N1</b> ↵	Set the WebGUI login password. <b>N1</b> = {password} [16 characters maximum]
<b>get webgui password</b> ↵	Show the current WebGUI login password.
<b>set webgui login timeout N1</b> ↵	Set the WebGUI inactivity timeout value or disable the timeout. Available values for <b>N1</b> : 0 [No timeout] 1~35790 [Minutes]
<b>get webgui login timeout</b> ↵	Show the current WebGUI inactivity timeout value.
<b>set webgui port N1</b> ↵	Set the unit's WebGUI access port. <b>N1</b> = 0~65535 [Port number]
<b>get webgui port</b> ↵	Show the unit's current WebGUI access port.
<b>set telnet port N1</b> ↵	Set the unit's Telnet access port. <b>N1</b> = 0~65535 [Port number]

## COMMAND

### Description and Parameters

#### **get telnet port**↵

Show the unit's current Telnet access port.

#### **set automation event N1 cec A N2**↵

Enable or disable the specified Automation Event's CEC response.

Available values for **N1**:

- |   |                          |
|---|--------------------------|
| 1 | [Power on]               |
| 2 | [Output A source active] |
| 3 | [Output A source lost]   |

Available values for **N2**:

- |     |           |
|-----|-----------|
| OFF | [Disable] |
| ON  | [Enable]  |

#### **get automation event N1 cec A**↵

Show the current state of the specified Automation Event's CEC response.

Available values for **N1**:

- |   |                          |
|---|--------------------------|
| 1 | [Power on]               |
| 2 | [Output A source active] |
| 3 | [Output A source lost]   |

#### **set automation event N1 cec A trig**↵

Trigger the CEC response of the specified Automation Event.

Available values for **N1**:

- |   |                          |
|---|--------------------------|
| 1 | [Power on]               |
| 2 | [Output A source active] |
| 3 | [Output A source lost]   |

#### **set automation event N1 cec A delay N2**↵

Set the delay time that the specified Automation Event must continue to be true before sending the defined CEC command.

Available values for **N1**:

- |   |                          |
|---|--------------------------|
| 1 | [Power on]               |
| 2 | [Output A source active] |
| 3 | [Output A source lost]   |

**N2** = 0~240 [Delay seconds]

## COMMAND

### Description and Parameters

#### **get automation event N1 cec A delay**↵

Show the delay time for the specified Automation Event's CEC response.

Available values for **N1**:

- |   |                          |
|---|--------------------------|
| 1 | [Power on]               |
| 2 | [Output A source active] |
| 3 | [Output A source lost]   |

#### **set automation event N1 cec A wait N2**↵

Set the length of time to wait after an Automation Event's CEC response has been activated before ANY other Automation Event can be detected.

Available values for **N1**:

- |   |                          |
|---|--------------------------|
| 1 | [Power on]               |
| 2 | [Output A source active] |
| 3 | [Output A source lost]   |

**N2** = 0~240 [Wait seconds]

#### **get automation event N1 cec A wait**↵

Show the wait time for the specified Automation Event's CEC response.

Available values for **N1**:

- |   |                          |
|---|--------------------------|
| 1 | [Power on]               |
| 2 | [Output A source active] |
| 3 | [Output A source lost]   |

#### **set automation event N1 cec A command N2**↵

Set the CEC command to send when the specified Automation Event is activated.

Available values for **N1**:

- |   |                          |
|---|--------------------------|
| 1 | [Power on]               |
| 2 | [Output A source active] |
| 3 | [Output A source lost]   |

**N2** = {CEC command} [Comma delimited ASCII hex pairs]

#### **get automation event N1 cec A command**↵

Show the CEC command to be sent when the specified Automation Event is activated.

## COMMAND

### Description and Parameters

#### set automation event N1 uart A N2↵

Enable or disable the specified Automation Event's RS-232 response.

Available values for **N1**:

1	[Power on]
2	[Output A source active]
3	[Output A source lost]

Available values for **N2**:

OFF	[Disable]
ON	[Enable]

#### get automation event N1 uart A↵

Show the current state of the specified Automation Event's RS-232 response.

Available values for **N1**:

1	[Power on]
2	[Output A source active]
3	[Output A source lost]

#### set automation event N1 uart A trig↵

Trigger the RS-232 response of the specified Automation Event.

Available values for **N1**:

1	[Power on]
2	[Output A source active]
3	[Output A source lost]

#### set automation event N1 uart A delay N2↵

Set the delay time that the specified Automation Event must continue to be true before sending the defined RS-232 command.

Available values for **N1**:

1	[Power on]
2	[Output A source active]
3	[Output A source lost]

**N2** = 0~240 [Delay seconds]

## COMMAND

### Description and Parameters

#### get automation event N1 uart A delay↵

Show the delay time for the specified Automation Event's RS-232 response.

Available values for **N1**:

1	[Power on]
2	[Output A source active]
3	[Output A source lost]

#### set automation event N1 uart A wait N2↵

Set the length of time to wait after an Automation Event's RS-232 response has been activated before ANY other Automation Event can be detected.

Available values for **N1**:

1	[Power on]
2	[Output A source active]
3	[Output A source lost]

**N2** = 0~240 [Wait seconds]

#### get automation event N1 uart A wait↵

Show the wait time for the specified Automation Event's RS-232 response.

Available values for **N1**:

1	[Power on]
2	[Output A source active]
3	[Output A source lost]

#### set automation event N1 uart A command N2↵

Set the RS-232 command string to send when the specified Automation Event is activated.

Available values for **N1**:

1	[Power on]
2	[Output A source active]
3	[Output A source lost]

**N2** = {Command} [ASCII text]

## COMMAND

### Description and Parameters

#### get automation event N1 uart A command↵

Show the RS-232 command string to be sent when the specified Automation Event is activated.

#### set automation event N1 ir A N2↵

Enable or disable the specified Automation Event's IR response.

Available values for **N1**:

- |   |                          |
|---|--------------------------|
| 1 | [Power on]               |
| 2 | [Output A source active] |
| 3 | [Output A source lost]   |

Available values for **N2**:

- |     |           |
|-----|-----------|
| OFF | [Disable] |
| ON  | [Enable]  |

#### get automation event N1 ir A↵

Show the current state of the specified Automation Event's IR response.

Available values for **N1**:

- |   |                          |
|---|--------------------------|
| 1 | [Power on]               |
| 2 | [Output A source active] |
| 3 | [Output A source lost]   |

#### set automation event N1 ir A emit↵

Trigger the IR response of the specified Automation Event.

Available values for **N1**:

- |   |                          |
|---|--------------------------|
| 1 | [Power on]               |
| 2 | [Output A source active] |
| 3 | [Output A source lost]   |

#### set automation event N1 ir A delay N2↵

Set the delay time that the specified Automation Event must continue to be true before sending the defined IR command.

Available values for **N1**:

- |   |                          |
|---|--------------------------|
| 1 | [Power on]               |
| 2 | [Output A source active] |
| 3 | [Output A source lost]   |

**N2** = 0~240 [Delay seconds]

## COMMAND

### Description and Parameters

#### **get automation event N1 ir A delay**↵

Show the delay time for the specified Automation Event's IR response.

Available values for **N1**:

1	[Power on]
2	[Output A source active]
3	[Output A source lost]

#### **set automation event N1 ir A wait N2**↵

Set the length of time to wait after an Automation Event's IR response has been activated before ANY other Automation Event can be detected.

Available values for **N1**:

1	[Power on]
2	[Output A source active]
3	[Output A source lost]

**N2** = 0~240 [Wait seconds]

#### **get automation event N1 ir A wait**↵

Show the wait time for the specified Automation Event's IR response.

Available values for **N1**:

1	[Power on]
2	[Output A source active]
3	[Output A source lost]

#### **set automation event N1 ir A learn**↵

Learn the IR command to send when the specified Automation Event is activated.

Available values for **N1**:

1	[Power on]
2	[Output A source active]
3	[Output A source lost]

COMMAND													
Description and Parameters													
<b>set uart 1 baudrate N1↵</b>	<p>Set the baud rate of the CTL RS-232 port.</p> <p>Available values for <b>N1</b>:</p> <table> <tr> <td>4800</td> <td>[4800 baud]</td> </tr> <tr> <td>9600</td> <td>[9600 baud]</td> </tr> <tr> <td>19200</td> <td>[19200 baud]</td> </tr> <tr> <td>38400</td> <td>[38400 baud]</td> </tr> <tr> <td>57600</td> <td>[57600 baud]</td> </tr> <tr> <td>115200</td> <td>[115200 baud]</td> </tr> </table>	4800	[4800 baud]	9600	[9600 baud]	19200	[19200 baud]	38400	[38400 baud]	57600	[57600 baud]	115200	[115200 baud]
4800	[4800 baud]												
9600	[9600 baud]												
19200	[19200 baud]												
38400	[38400 baud]												
57600	[57600 baud]												
115200	[115200 baud]												
<b>get uart 1 baudrate↵</b>	<p>Show the current baud rate of the CTL RS-232 port.</p>												
<b>set uart 1 data bit N1↵</b>	<p>Set the data bits for the CTL RS-232 port.</p> <p><b>N1</b> = 5~8 [Data bits]</p>												
<b>get uart 1 data bit↵</b>	<p>Show the current number of data bits of the CTL RS-232 port.</p>												
<b>set uart 1 parity N1↵</b>	<p>Set the parity of the CTL RS-232 port.</p> <p>Available values for <b>N1</b>:</p> <table> <tr> <td>0</td> <td>[None]</td> </tr> <tr> <td>1</td> <td>[Odd]</td> </tr> <tr> <td>2</td> <td>[Even]</td> </tr> </table>	0	[None]	1	[Odd]	2	[Even]						
0	[None]												
1	[Odd]												
2	[Even]												
<b>get uart 1 parity↵</b>	<p>Show the current parity setting of the CTL RS-232 port.</p>												
<b>set uart 1 stop bit N1↵</b>	<p>Set the number of stop bits for the CTL RS-232 port.</p> <p><b>N1</b> = 1 ~ 2 [Stop bits]</p>												
<b>get uart 1 stop bit↵</b>	<p>Show the current number of stop bits of the CTL RS-232 port.</p>												

COMMAND									
Description and Parameters									
<b>set ir in channel N1</b> ↵	<p>Set the channel for the IR input to use.</p> <p>Available values for <b>N1</b>:</p> <table> <tr> <td>0</td> <td>[Channel 0]</td> </tr> <tr> <td>1</td> <td>[Channel 1]</td> </tr> <tr> <td>2</td> <td>[Channel 2]</td> </tr> <tr> <td>3</td> <td>[Channel 3]</td> </tr> </table>	0	[Channel 0]	1	[Channel 1]	2	[Channel 2]	3	[Channel 3]
0	[Channel 0]								
1	[Channel 1]								
2	[Channel 2]								
3	[Channel 3]								
<b>get ir in channel</b> ↵	<p>Show the current channel used by the IR input.</p>								
<b>set ir in custom code N1</b> ↵	<p>Set the custom code used by the IR input.</p> <p><b>N1</b> = {ASCII hex}                      [Custom code]</p>								
<b>get ir in custom code</b> ↵	<p>Show the current custom code used by the IR input.</p>								
<b>set relay N1 N2</b> ↵	<p>Open or close the specified relay.</p> <p><b>N1</b> = 1~4                                      [Relay port]</p> <p>Available values for <b>N2</b>:</p> <table> <tr> <td>OFF</td> <td>[Relay open]</td> </tr> <tr> <td>ON</td> <td>[Relay closed]</td> </tr> </table>	OFF	[Relay open]	ON	[Relay closed]				
OFF	[Relay open]								
ON	[Relay closed]								
<b>get relay N1</b> ↵	<p>Show the current state of the specified relay.</p> <p><b>N1</b> = 1~4                                      [Relay port]</p>								
<b>set factory default</b> ↵	<p>Reset the unit to the factory defaults.</p>								
<b>set system reboot</b> ↵	<p>Reboot the unit.</p>								
<b>get fw ver</b> ↵	<p>Show the unit's current firmware version.</p>								

**COMMAND****Description and Parameters****update mcu↵**

Initiate firmware update via the USB port.

*Note: Commands will not be executed unless followed by a carriage return. Commands are not case-sensitive.*

## 7. CONNECTION DIAGRAM

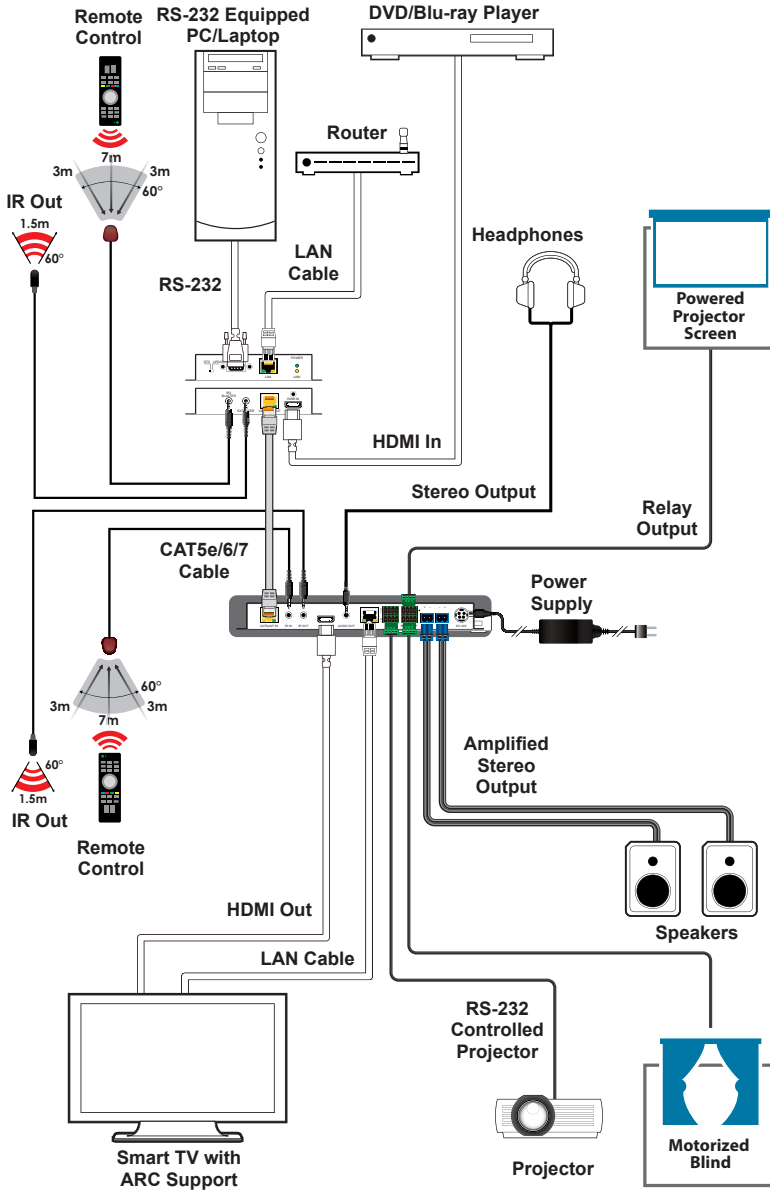

## 8. SPECIFICATIONS

### 8.1 Technical Specifications

<b>HDMI Bandwidth</b>	18Gbps
<b>HDBaseT Bandwidth</b>	10.2Gbps
<b>Input Ports</b>	1×HDMI (Type-A) 1×HDBaseT (RJ-45)
<b>Output Ports</b>	1×HDMI (Type-A) 1×Stereo Audio (3.5mm) 1×Stereo Audio (2×2-pin Term. Block)
<b>Pass-through Ports</b>	1×IR Extender (3.5mm) 1×IR Blaster (3.5mm) 1×RS-232 (4-pin Terminal Block) 4×Power Relay (2-pin Terminal Block)
<b>Pass-through/Control Port</b>	1×LAN (RJ-45)
<b>Control Port</b>	1×RS-232 (4-pin Terminal Block)
<b>Service Port</b>	1×USB 2.0 (Type A)
<b>IR Frequency</b>	30 – 50kHz (30 – 60kHz under ideal conditions)
<b>Baud Rate</b>	19200 (Control) Up to 115200 (Bypass)
<b>Power Supply</b>	24V/3.75A DC (US/EU standards, CE/FCC/UL certified)
<b>ESD Protection (HBM)</b>	±8kV (Air Discharge) ±4kV (Contact Discharge)
<b>Dimensions (W×H×D)</b>	231.5mm×25mm×108mm [Case Only] 231.5mm×25mm×112mm [All Inclusive]
<b>Weight</b>	679g
<b>Chassis Material</b>	Metal (Steel)
<b>Chassis Color</b>	Black
<b>Operating Temperature</b>	0°C – 40°C/32°F – 104°F
<b>Storage Temperature</b>	-20°C – 60°C/-4°F – 140°F
<b>Relative Humidity</b>	20 – 90% RH (Non-condensing)
<b>Power Consumption</b>	91.63W

## 8.2 Video Specifications

Supported Resolutions (Hz)	Input		Output
	HDMI	HDBaseT	HDMI
720×400p@70/85	✓	✓	✓
640×480p@60/72/75/85	✓	✓	✓
720×480i@60	✓	✓	✓
720×480p@60	✓	✓	✓
720×576i@50	✓	✓	✓
720×576p@50	✓	✓	✓
800×600p@56/60/72/75/85	✓	✓	✓
848×480p@60	✓	✓	✓
1024×768p@60/70/75/85	✓	✓	✓
1152×864p@75	✓	✓	✓
1280×720p@50/60	✓	✓	✓
1280×768p@60/75/85	✓	✓	✓
1280×800p@60/75/85	✓	✓	✓
1280×960p@60/85	✓	✓	✓
1280×1024p@60/75/85	✓	✓	✓
1360×768p@60	✓	✓	✓
1366×768p@60	✓	✓	✓
1400×1050p@60	✓	✓	✓
1440×900p@60/75	✓	✓	✓
1600×900p@60RB	✓	✓	✓
1600×1200p@60	✓	✓	✓
1680×1050p@60	✓	✓	✓
1920×1080i@50/60	✓	✓	✓
1920×1080p@24/25/30	✓	✓	✓
1920×1080p@50/60	✓	✓	✓
1920×1200p@60RB	✓	✓	✓

Supported Resolutions (Hz)	Input		Output
	HDMI	HDBaseT	HDMI
2560×1440p@60RB	✓	✓	✓
2560×1600p@60RB	✓	✓	✓
2048×1080p@24/25/30	✓	✓	✓
2048×1080p@50/60	✓	✓	✓
3840×2160p@24/25/30	✓	✓	✓
3840×2160p@50/60 (4:2:0)	✓	✓	✓
3840×2160p@24, HDR10	✓	×	✓
3840×2160p@50/60 (4:2:0), HDR10	✓	×	✓
3840×2160p@50/60	✓	×	✓
4096×2160p@24/25/30	✓	✓	✓
4096×2160p@50/60 (4:2:0)	✓	✓	✓
4096×2160p@24, HDR10	✓	×	✓
4096×2160p@50/60 (4:2:0), HDR10	✓	×	✓
4096×2160p@50/60	✓	×	✓

## 8.3 Audio Specifications

### 8.3.1 Digital Audio

HDMI Input / Output	
LPCM	
Max Channels	8 Channels
Sampling Rate (kHz)	32, 44.1, 48, 88.2, 96, 176.4, 192
Bitstream	
Supported Formats	Standard & High-Definition
HDBaseT Input	
LPCM	
Max Channels	8 Channels
Sampling Rate (kHz)	32, 44.1, 48, 88.2, 96, 176.4, 192
Bitstream	
Supported Formats	Standard & High-Definition

### 8.3.2 Analog Audio

Analog Output (3.5mm)	
Max Audio Level	2Vrms
THD+N	< -80dB@0dBFS 1kHz (A-wt)
SNR	> 110dB@0dBFS
Frequency Response	< ±1dB@20Hz~20kHz
Crosstalk	< -88dB@10kHz
Impedance	499Ω
Type	Unbalanced
Analog Output (2-pin Terminal Block Pair)	
Max Audio Level	20W+20W
THD+N	< -62dB@0dBFS 1kHz (A-wt)
SNR	> 102dB@0dBFS
Frequency Response	< ±3dB@20Hz~20kHz
Crosstalk	< -84dB@10kHz
Impedance	4Ω
Type	Balanced

## 8.4 Cable Specifications

Cable Length	1080p		4K30	4K60
	8-bit	12-bit	(4:4:4) 8-bit	(4:4:4) 8-bit
<b>High Speed HDMI Cable</b>				
HDMI Input	15m	10m	5m	3m
HDMI Output	15m	10m	5m	3m
<b>Ethernet Cable</b>				
Cat.5e/6	100m		70m	×
Cat.6A/7	100m		100m	×

### Bandwidth Category Examples:

- **1080p (FHD Video)**
  - Up to 1080p@60Hz, 12-bit color
  - Data rates lower than 5.3Gbps or below 225MHz TMDS clock
- **4K30 (4K UHD Video)**
  - 4K@24/25/30Hz & 4K@50/60Hz (4:2:0), 8-bit color
  - Data rates higher than 5.3Gbps or above 225MHz TMDS clock but below 10.2Gbps
- **4K60 (4K UHD+ Video)**
  - 4K@50/60Hz (4:4:4, 8-bit)
  - 4K@50/60Hz (4:2:0, 10-bit HDR)
  - Data rates higher than 10.2Gbps

## 8.5 HDBaseT Features

HDBaseT Feature Set	Receiver
Video & Audio Extension	Supported
LAN Extension	Supported
Send power to Transmitter	Supported (PoH)
Accept power from Transmitter	Unsupported
IR Extension	Supported
RS-232 Extension	Supported
USB 2.0 Extension	Unsupported

## 9. ACRONYMS

ACRONYM	COMPLETE TERM
<b>ARC</b>	Audio Return Channel
<b>ASCII</b>	American Standard Code for Information Interchange
<b>Cat.5e</b>	Enhanced Category 5 cable
<b>Cat.6</b>	Category 6 cable
<b>Cat.6A</b>	Augmented Category 6 cable
<b>Cat.7</b>	Category 7 cable
<b>CEC</b>	Consumer Electronics Control
<b>CLI</b>	Command-Line Interface
<b>DAC</b>	Digital-to-Analog Converter
<b>dB</b>	Decibel
<b>DHCP</b>	Dynamic Host Configuration Protocol
<b>DVI</b>	Digital Visual Interface
<b>EDID</b>	Extended Display Identification Data
<b>Gbps</b>	Gigabits per second
<b>GUI</b>	Graphical User Interface
<b>HDBT</b>	HDBaseT
<b>HDCP</b>	High-bandwidth Digital Content Protection
<b>HDMI</b>	High-Definition Multimedia Interface
<b>HDR</b>	High Dynamic Range
<b>IP</b>	Internet Protocol
<b>IR</b>	Infrared
<b>kHz</b>	Kilohertz
<b>LAN</b>	Local Area Network
<b>LED</b>	Light-Emitting Diode
<b>LPCM</b>	Linear Pulse-Code Modulation
<b>MAC</b>	Media Access Control
<b>MHz</b>	Megahertz
<b>OSD</b>	On-Screen Display

<b>ACRONYM</b>	<b>COMPLETE TERM</b>
<b>PD</b>	Powered Device
<b>PoH</b>	Power over HDBaseT
<b>PSE</b>	Power Sourcing Equipment
<b>SNR</b>	Signal-to-Noise Ratio
<b>TCP</b>	Transmission Control Protocol
<b>THD+N</b>	Total Harmonic Distortion plus Noise
<b>4K UHD</b>	4K Ultra-High-Definition (10.2Gbps max)
<b>4K UHD+</b>	4K Ultra-High-Definition (18Gbps max)
<b>USB</b>	Universal Serial Bus
<b>VGA</b>	Video Graphics Array
<b>WUXGA (RB)</b>	Widescreen Ultra Extended Graphics Array (Reduced Blanking)
<b>XGA</b>	Extended Graphics Array
<b>Ω</b>	Ohm





**CYPRESS TECHNOLOGY CO., LTD.**  
[www.cypress.com.tw](http://www.cypress.com.tw)

---