



DCT-37

UHD Audio Center



4Kx2K+
HDCP 2.2

Operation Manual



DISCLAIMERS

The information in this manual has been carefully checked and is believed to be accurate. Cypress Technology assumes no responsibility for any infringements of patents or other rights of third parties which may result from its use.

Cypress Technology assumes no responsibility for any inaccuracies that may be contained in this document. Cypress also makes no commitment to update or to keep current the information contained in this document.

Cypress Technology reserves the right to make improvements to this document and/or product at any time and without notice.

COPYRIGHT NOTICE

No part of this document may be reproduced, transmitted, transcribed, stored in a retrieval system, or any of its part translated into any language or computer file, in any form or by any means—electronic, mechanical, magnetic, optical, chemical, manual, or otherwise—without express written permission and consent from Cypress Technology.

© Copyright 2015 by Cypress Technology.

All Rights Reserved.

TRADEMARK ACKNOWLEDGMENTS

All products or service names mentioned in this document may be trademarks of the companies with which they are associated.



SAFETY PRECAUTIONS

Please read all instructions before attempting to unpack, install or operate this equipment and before connecting the power supply.

Please keep the following in mind as you unpack and install this equipment:

- Always follow basic safety precautions to reduce the risk of fire, electrical shock and injury to persons.
- To prevent fire or shock hazard, do not expose the unit to rain, moisture or install this product near water.
- Never spill liquid of any kind on or into this product.
- Never push an object of any kind into this product through any openings or empty slots in the unit, as you may damage parts inside the unit.
- Do not attach the power supply cabling to building surfaces.
- Use only the supplied power supply unit (PSU). Do not use the PSU if it is damaged.
- Do not allow anything to rest on the power cabling or allow any weight to be placed upon it or any person walk on it.
- To protect the unit from overheating, do not block any vents or openings in the unit housing that provide ventilation and allow for sufficient space for air to circulate around the unit.

REVISION HISTORY

VERSION NO.	DATE (DD/MM/YY)	SUMMARY OF CHANGE
RDV1	10/06/15	Preliminary release
RDV2	02/03/16	updated Chapter 1
	28/07/17	Content updates





CONTENTS

1. Introduction	1
2. Applications	1
3. Package Contents	2
4. System Requirements	2
5. Features	2
6. Operation Controls and Functions	4
6.1 Front Panel	4
6.2 Rear Panel.....	5
6.3 Top Panel	6
6.4 Remote Control.....	7
6.5 OLED Menu	10
7. Connection Diagram	13
8. Specifications	14
8.1 Technical Specifications	14
8.2 Audio Specification	15
9. Acronyms	15



1. INTRODUCTION

The UHD Audio Center is designed to allow multiple analog/digital audio sources to be controlled, switched and output to a variety of analog/digital audio equipment. With video supports up to 6G at 4K2K and audio sampling rate converter up to 384KHz this device has an unbeatable feature you can find in the market. Also it supports 2CH LPCM audio, HDMI, USB Audio 2.0, Optical and Coaxial input/output with both ADC and DAC functions. USB could supports DOP (DSD over PCM) decoded, with high sampling frequency to perform high quality and lower the probability of distortion.

For professional, headphone output with build-in amplifier and XLR (Low noise Professional Balance) output offer unparalleled audio quality. Traditional 3.5mm earphone jack analog input and stereo RCA output with a highly accurate PLL and low jitter reduction clock system allows user with total enjoyment over the original sound. OLED display with on-panel control and IR remote control leave user with friendly use over the device.

2. APPLICATIONS

- Audio format conversion and sampling upgrade
- Professional audio display
- PC audio display onto professional speakers/headphone
- Analog to digital or digital to analog audio conversion



3. PACKAGE CONTENTS

- 1×UHD Audio Center
- 1×Remote Control (with Battery)
- 1×USB Driver Disc
- 1×6.3mm to 3.5mm Phone Jack Cable
- 1×5V/3A Power Adaptor
- 1×Operation Manual

4. SYSTEM REQUIREMENTS

Input source equipment such as CD /DVD player or computer via USB, optical or analog stereo output to amplifier or speaker with analog stereo output.

5. FEATURES

Digital

- Supports Coaxial, Optical, USB and 4 HDMI inputs
- Supports HDMI, Coaxial and Optical outputs
- Supports digital audio signal input and conversion into analog stereo
- Supports HDMI Audio output can either output the incoming embedded HDMI (Bypass Mode) or insert the selected audio signal (Ext Audio Mode)
- HDMI video always bypassed to HDMI output
- Supports HDMI video resolutions up to 4K2K (3840×2160@24/25/30/50/60Hz & 4096×2160@24/25/30/50/60Hz)
- Supports HDMI data rate up to 6Gbps and Deep Color up to 1080p 36bit
- Support Coaxial Input/ output and USB input sampling rate up to 384kHz/32bits.
- Coaxial and Optical input support DOP decode to PCM
- HDMI audio embedding or de-embedding
- Supports Sampling Rate Conversion, all inputs can be SRC to 44.1, 48, 88.2, 96, 176.4, 192 and 384kHz via DSP Engine

Analog

- Supports L/R in/output, XLR and 6.3mm headphone outputs
- Supports analog audio signal input converts into digital signal output
- Supports Headphone/Line output Volume Control
- Headphone/Line output volume control over main control dial or remote control
- Headphone output fades in after system is muted
- 6.3mm headphone output

Misc

- Control by remote control and on-panel wheel
- Direct power and mute button on unit
- High viewing angle OLED display
- Free Run: Auto 720P Colorbar Pattern Output when no video source is connected.



6. OPERATION CONTROLS AND FUNCTIONS

6.1 Front Panel

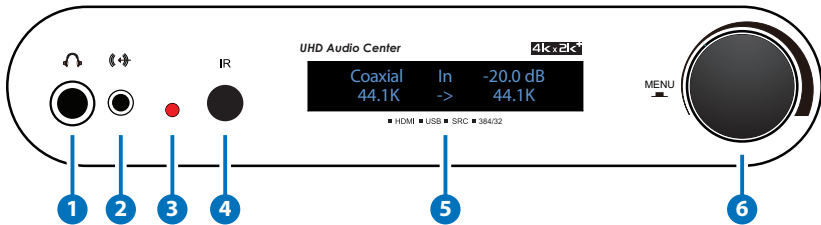

- 1 6.3mm HEADPHONE OUT:** This slot is to connect with 6.3mm professional headphone set for user to enjoy the individual professional audio sound.
- 2 3.5mm LINE IN:** This slot is to connect with 3.5mm phone jack cable from any audio equipment for stereo line in input audio signal.
- 3 POWER LED:** The LED will illuminate red when the device is connected with power supply (standby), and will turn green if turn on the device.
- 4 IR WINDOW:** This is the IR receiver window that accept IR signal from the remote control of this device that is included in the package.
- 5 OLED:** This OLED LCM displays the in/output selection with volume setting, sampling rate and audio channels.
- 6 MENU/VOLUME CONTROL:** Press this button to enter into the menu selection or rotate to adjust the volume.

6.2 Rear Panel

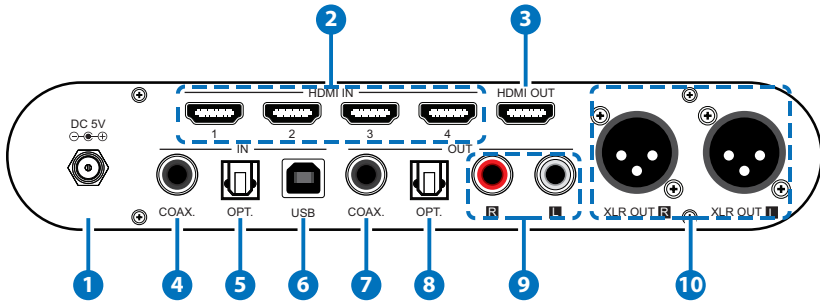

- 1 DC 5V:** Plug the 5V DC power adaptor included in the package into the unit and connect the adaptor to an AC outlet for power supply.
- 2 HDMI IN 1~4:** Connect to the HDMI input source equipment such as DVD/ Blu-ray player with 6G HDMI signal sending with HDMI cable. 6G signal are support on all 4 ports.
- 3 HDMI OUT:** Connect to HDTV/monitor for output image display with 6G HDMI signal sending from HDMI cables.
- 4 COAX. IN:** Connect with input source equipment such as Set-Top-Box or PS3 for input audio signal sending with Coaxial cable.
- 5 OPT. IN:** Connect with input source equipment such as DVD/Blu-ray player for input audio signal sending with Optical cable.
- 6 USB IN:** This slot is to connect with PC/NB source equipment for USB audio signal input sending. Also this slot could use on firmware upgrade.
Note: USB input need to install drivers and applications from the disc which contained on package.
- 7 COAX. OUT:** Connect to amplifier or active speaker with coaxial cable.
- 8 OPT. OUT:** Connect to amplifier or active speaker with optical cable.
- 9 L/R OUT:** Connect to amplifier or active speaker with RCA jack cable.
- 10 XLR (L/R) OUT:** These slots are to connect from output amplifier or directly to professional output speakers with XLR cables. Balanced



audio allows for the use of long cables while reducing susceptibility to external noise.

6.3 Top Panel

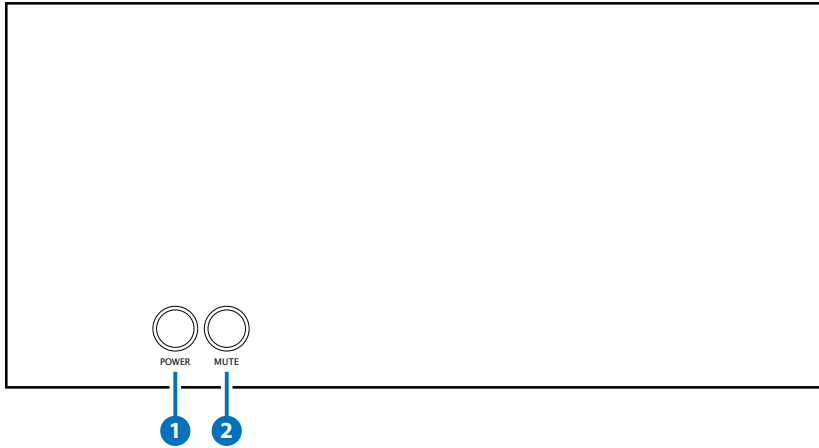







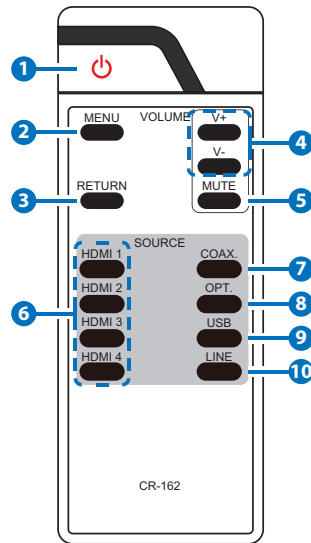









- 1 POWER:** Press this button to switch on the device or turn it to standby mode.
- 2 MUTE:** Press this button to mute all volume instantly.

6.4 Remote Control

- 1 **POWER:** Press to turn the unit power on or set to standby mode.
- 2 **MENU:** Press the key to enter OSD menu, use V+/V- to go up and down between the menu selections, press again to enter submenu.
- 3 **RETURN:** When in the menu, press this to go back upper layer or exit from menu selections.
- 4 **VOLUME +/-:** Press V+ / V- to control output volume up and down. When press MENU key into menu selections, use V+ / V- to go up and down menu selections.
- 5 **MUTE:** Press this button to mute all audio volume, press again to unmute.
- 6 **HDMI 1~4:** Press these hot keys to select HDMI input sources from 1~4.
- 7 **COAX.:** Press this hot key to switch input source to Coaxial input.
- 8 **OPT.:** Press to select Optical input.
- 9 **USB:** Press to select USB input.
- 10 **LINE:** Press to select LINE input.



REMOTE CONTROL SETTING	IR CHANNEL
<p style="text-align: center;">ON DIP</p>  <p style="text-align: center;">1 2 3 4</p>	0
<p style="text-align: center;">ON DIP</p>  <p style="text-align: center;">1 2 3 4</p>	1
<p style="text-align: center;">ON DIP</p>  <p style="text-align: center;">1 2 3 4</p>	2
<p style="text-align: center;">ON DIP</p>  <p style="text-align: center;">1 2 3 4</p>	3
<p style="text-align: center;">ON DIP</p>  <p style="text-align: center;">1 2 3 4</p>	4
<p style="text-align: center;">ON DIP</p>  <p style="text-align: center;">1 2 3 4</p>	5
<p style="text-align: center;">ON DIP</p>  <p style="text-align: center;">1 2 3 4</p>	6
<p style="text-align: center;">ON DIP</p>  <p style="text-align: center;">1 2 3 4</p>	7
<p style="text-align: center;">ON DIP</p>  <p style="text-align: center;">1 2 3 4</p>	8

REMOTE CONTROL SETTING	IR CHANNEL
<p style="text-align: center;">ON DIP</p>  <p style="text-align: center;">1 2 3 4</p>	9
<p style="text-align: center;">ON DIP</p>  <p style="text-align: center;">1 2 3 4</p>	10
<p style="text-align: center;">ON DIP</p>  <p style="text-align: center;">1 2 3 4</p>	11
<p style="text-align: center;">ON DIP</p>  <p style="text-align: center;">1 2 3 4</p>	12
<p style="text-align: center;">ON DIP</p>  <p style="text-align: center;">1 2 3 4</p>	13
<p style="text-align: center;">ON DIP</p>  <p style="text-align: center;">1 2 3 4</p>	14
<p style="text-align: center;">ON DIP</p>  <p style="text-align: center;">1 2 3 4</p>	15



6.5 OLED Menu

MAIN MENU	SUB MENU		DESCRIPTION	DEFAULT
Source In	HDMI 1 IN		Input selection	HDMI 1
	HDMI 2 IN			
	HDMI 3 IN			
	HDMI 4 IN			
	Coaxial IN			
	Optical IN			
	USB IN			
	Line IN			
	Return			
SRC Set	Bypass		Set output SRC Frequency	BYPASS
	384 kHz			
	192 kHz			
	176.4 kHz			
	96 kHz			
	88.2 kHz			
	48 kHz			
	44.1 kHz			
	Return			
HDMI RX Set	EDID	FHD(2CH)	Set internal EDID format	FHD(2CH)
		UHD(2CH)		
		UHD+(2CH)		
		SINK(2CH)		
		Return		

MAIN MENU	SUB MENU		DESCRIPTION	DEFAULT
HDMI TX Set	VIDEO	HDMI 1	Set HDMI input and Audio	Follow Audio
		HDMI 2		
		HDMI 3		
		HDMI 4		
		Follow Audio		
		Return		
	AUDIO	Bypass		Bypass
		Ext Audio		
Return				
Return				
Diplay Set	TimeOut 5s		Set LCM display time	TimeOut 15s
	TimeOut 10s			
	TimeOut 15s			
	Return			
HeadPhone Vol Set	Fix Level		Set Headphone Volume mode	Volume Level
	Volume Level			
	Return			
Firmware	Version		Show Firmware Version	N/A
	Update?		Update Firmware	
	Return			
Reset to Default				
AUTO POWER ON	OFF		Set Auto power on status	OFF
	ON			
	Last State			
	Return			



MAIN MENU	SUB MENU	DESCRIPTION	DEFAULT
IR Channel	0	Set Remote Control IR Channel	0
	1		
	2		
	3		
	4		
	5		
	6		
	7		
	8		
	9		
	10		
	11		
	12		
	13		
	14		
	15		
Return			
Freerun Pattern	OFF	Set Freerun Pattern	Color Bar
	Color Bar		
	Black		
	Gray		
	Blue		
	Green		
	Red		
	Return		
Return			

7. CONNECTION DIAGRAM

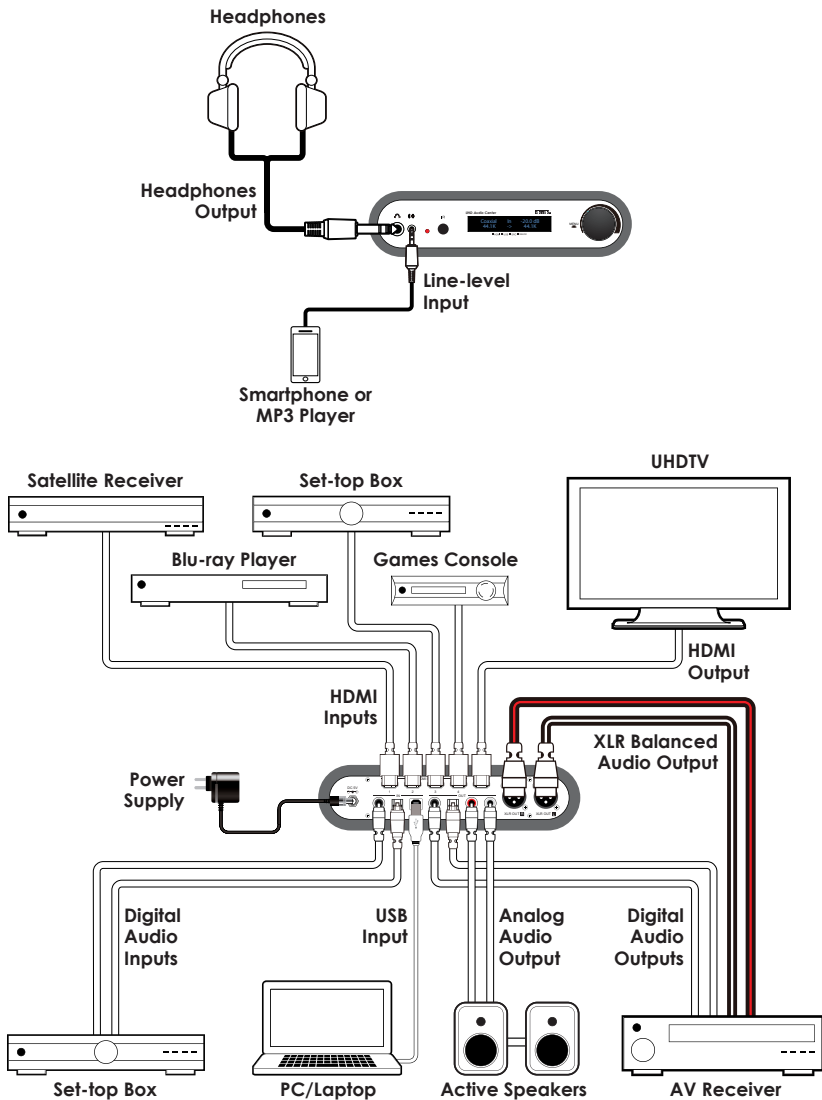



8. SPECIFICATIONS

8.1 Technical Specifications

Video Bandwidth	600 MHz/18 Gbps
Input Ports	4×HDMI, 1×Coaxial, 1×Optical, 1×USB (Type B), 1×3.5mm Phone Jack (Line-in)
Output Ports	1×HDMI, 1×Coaxial, 1×Optical, 2×RCA (Analog Stereo), 1×XLR (Balanced Audio), 1×6.3mm Phone Jack (Headphone)
HDMI Resolutions	VGA~WUXGA (RB), 408i~1080p@24/50/60, 4K@24/25/30, 4K@50/60 (YUV420)
Digital Audio I/O Format	LPCM 2CH
XLR Balanced Audio I/O Level	4Vrms±0.2
Headphone Impedance	16Ω~600Ω
Power Supply	5V/3A DC (US/EU standards, CE/FCC/UL certified)
ESD Protection	Human body model: ±8 kV (air-gap discharge) ±4 kV (contact discharge)
Dimensions	223 mm (W)×124 mm (D)×43 mm (H)/ Jack Excluded 223 mm (W)×145 mm (D)×48 mm (H)/ Jack Included
Weight	886 g
Chassis Material	Aluminum
Color	Black
Operating Temperature	0°C~40°C/32°F~104°F
Storage Temperature	-20°C~60°C/-4°F~140°F
Relative Humidity	20~90% RH (non-condensing)
Power Consumption	14.5 W

8.2 Audio Specification

Input Level/Freq.	Output	Output Level	THD+N	Frequency Response	SNR >90dB	Crosstalk <-90dB
HDMI 2Vrms*/1kHz	HDMI (Ext Audio)	-0.000	0.00001%	±1 dBFS	>141dB	<-110dB
Optical 2Vrms*/1kHz	Optical	-0.000	0.00001%	±1 dBFS	>141dB	<-164dB
Coaxial 2Vrms*/1kHz	Coaxial	-0.000	0.00001%	±1 dBFS	>141dB	<-163dB
Analog Line 2Vrms*/1kHz	Analog(L/R)	1.864	0.001%	±1 dBFS	>110dB	<-164dB
USB 2Vrms*/1kHz	Analog(XL/XR)	3.922	0.001%	±1 dBFS	>111dB	<-118dB

9. ACRONYMS

ACRONYM	COMPLETE TERM
COAX	Coaxial
HDCP	High-bandwidth Digital Content Protection
HDMI	High-Definition Multimedia Interface
IR	Infrared
OLED	Organic Light-Emitting Diode
OPT	Optical
USB	Universal Serial Bus
VGA	Video Graphics Array
WUXGA (RB)	Widescreen Ultra Extended Graphics Array (Reduce Blanking)



CYPRESS TECHNOLOGY CO., LTD

Home page: <http://www.cypress.com.tw>