

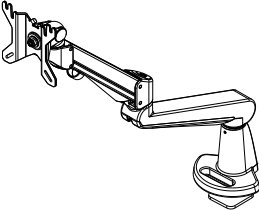







## Monitor arm STOCKHOLM 8-14 kg

Follow instructions, and if there are steps that are incomprehensible, please let us know and we will get back to you.

### Part Check-List

①		x1	④		x1
②		x1	⑤		x1
③		x1	6A		x4
			6B		x4
			⑦		x4

### STEP 1

Use the 2 mm Allen key ② to loosen the screw that is keeping the arms of the monitor arm ① in the clamp and remove it as seen in the illustration. Put the arm and hexagon cup point screw aside somewhere close and safe as it will be re-inserted for **STEP 3**.

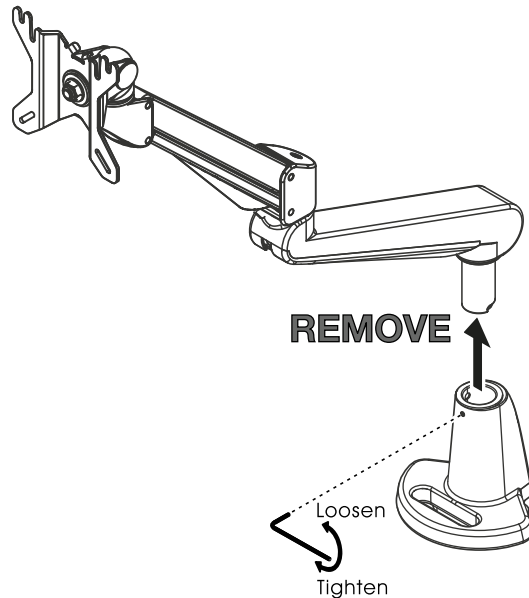

[www.kondator.se](http://www.kondator.se)

### STEP 2

Turn grommet upside down and adhere the Pad ③. Use Allen Key ④ to adjust the height of the clamp so that it fits your table. Tighten until sturdy and ascertain that the clamp can not be moved from its position from the table.

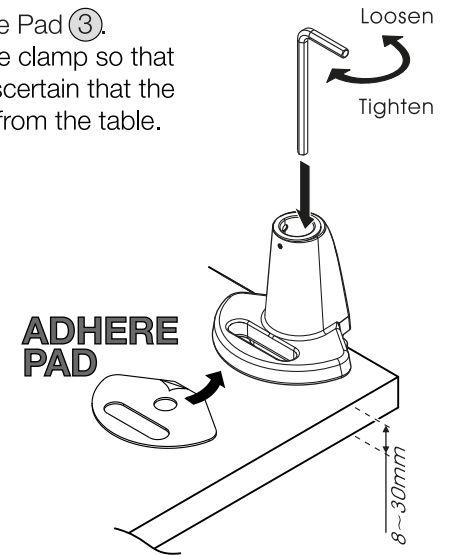
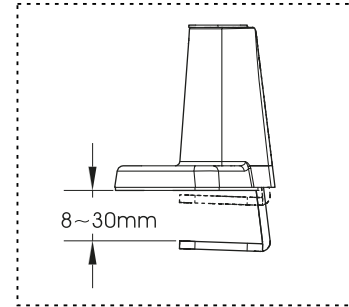

### STEP 3

Insert the removed arms into the clamp and fasten the hexagon cup point screw with the Allen key ②. Adjust the tension of the rotation to your need.

To keep the arms completely rigid, fasten the small cup point socket screws as tight as possible while maintaining the intended position.

**Optional:** Fasten the screw with the Allen key ② if you desire to limit the rotational movements to 180°.

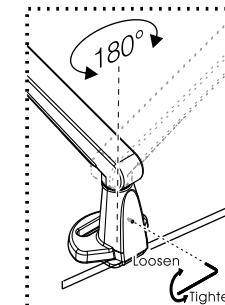

### RE-INSERT

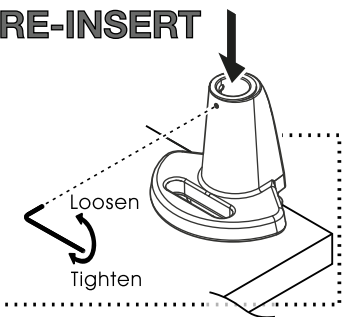

# Assembly Guide

## STEP 4

If the VESA mount fits with the monitor, proceed with the usage of screws (6A). (See left side illustration below).

In case it does not, assembly using the distance nuts (7) and long screws (6B). This is usually the case with screens that have a sunken VESA surface (see right side illustration below).

Secure the assembly with a screwdriver (not provided).

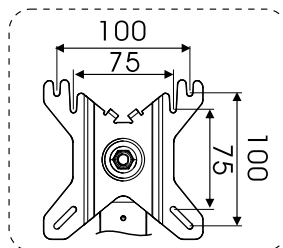

6A



1 Mount both upper screws half-way into the threads of the monitor.

2 Slide the upper screws onto the tracks of the monitor's VESA bracket.

3 Fasten all four screws to the monitor arm.

6B



7



1 Fasten all the nuts and screws onto the VESA bracket.

2 Grip firmly and position the monitor with the monitor's VESA bracket. Fasten all screws.

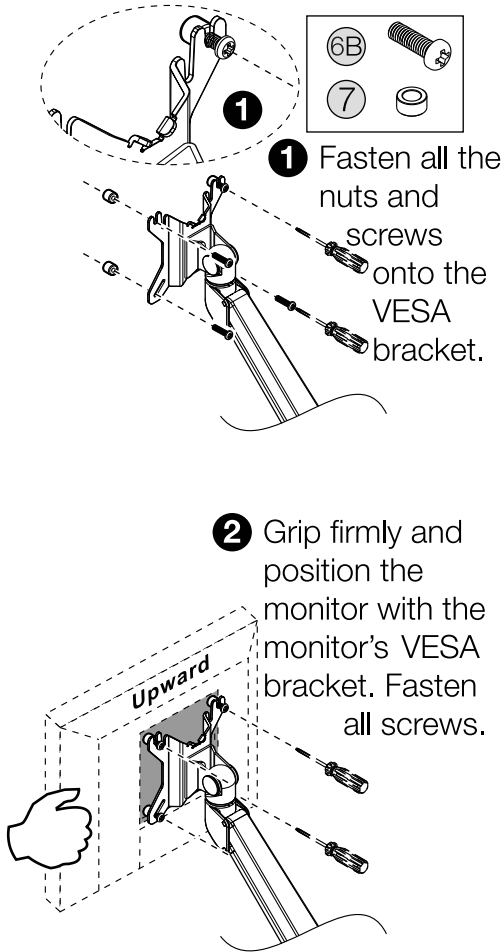
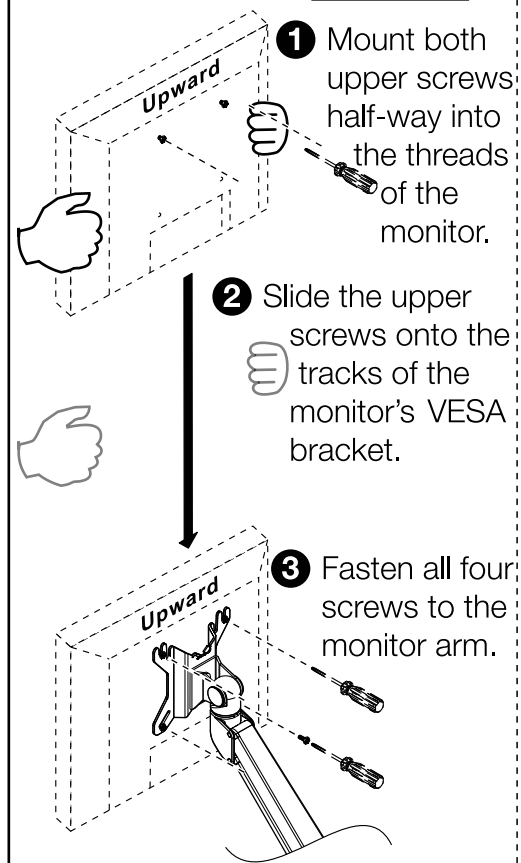

www.kondator.se

# Assembly Guide

## STEP 5

Unattach the cable collector and route the cables through. Once satisfied, re-attach the collector back into place. Proceed by continuing the routing through the cable clip.

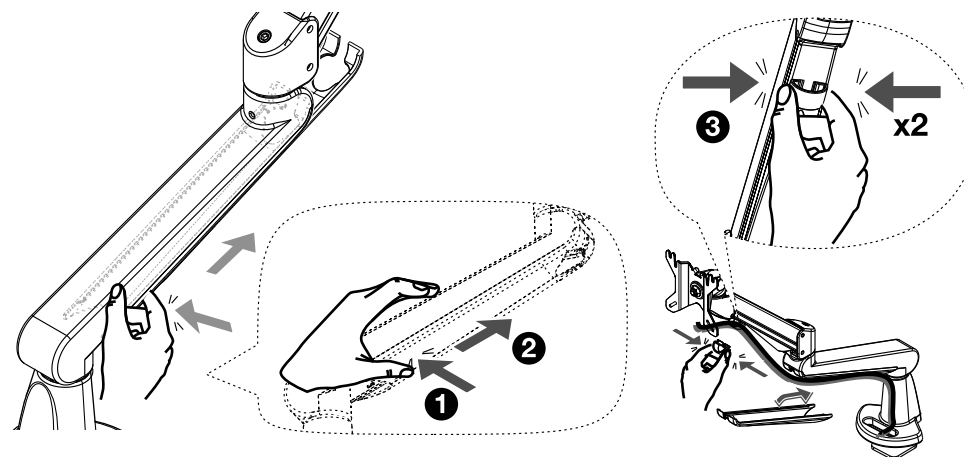

## Tension Adjustment

### Caution:

Support and hold on to the arm while adjusting the tension.

### Adjustment:

Use the Allen key provided to adjust the tension to correspond to the weight of the desired monitor. Turn the Allen key 5 counter-clockwise to adjust for heavier monitors; clockwise for lighter monitors. Once the adjustment is done, the monitor should be experienced as weightless and the monitor should remain in any position without dropping nor rising.

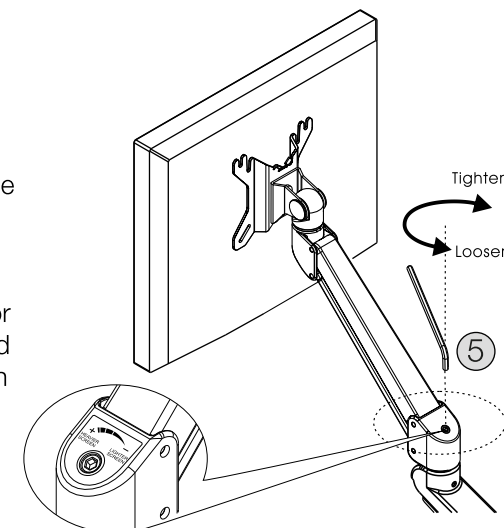

### Recommendations:

- 8-14 kg (17.6-30.8 lbs).
- The products loading capacities are based on monitors' center of gravity less than 3 cm from the end of the VESA interface.
- Loading capacity could be reduced if the monitor size is greater than 26 inches or if the thickness exceeds 5.5 cm.
- All product specifications in catalogues are subject to change without notice.